

Physiomodel 1.0 structure

(using of Physiobrary 3.2.1)

www.physiomodel.org

www.physiolibrary.org

Reimplementation and extension of HumMod Model in Modelica

hummod.org

Structure – vlastnosti

Obecné | Sdílení | Zabezpečení | Přizpůsobit

Structure

Typ: Složka souborů

Umístění: G:\Hummod 1.6\HumMod-hummod-standalone-2

Velikost: 1.30 MB (1 370 265 bajtů)

Velikost na disku: 3.73 MB (3 911 680 bajtů)

Obsahuje: 991 souborů, 149 složek

Vytvořeno: 24. listopadu 2011, 7:13:20

Atributy: Jen pro čtení (platí pouze pro soubory ve složce)

Storno Použít

991 XML files



Modelica

HumMod | The best, most complete, mathematical model of human physiology ever created.

Hi. We're HumMod.

The best, most complete, mathematical model of human physiology ever created.

Windows-only for the time being.

[Get Started](#)

We power [JustPhysiology.com](#)

Our model is being used by Just Physiology to leverage the power and comprehensive nature of our tool with a stunning graphical interface for teaching the next generation of physiology experts.

[Go To justphysiology.com](#)

Features and Origin

- ✓ Over 5,000 variables
- ✓ Completely customizable
- ✓ Open-sourced descriptions
- ✓ Published in peer-reviewed literature

[Read the origin story](#)

Other Projects

Editor

Want to create your own models? Fuss with HumMod's physiology?

[Get the Editor](#)

Help & Feedback

Knowledge Base

This is our starting point for the collective knowledge of HumMod. New tutorials, information, etc. appears in the Knowledge Base first.

[Experience the Knowledge Base](#)

Physiomodel Structure

- Physiomodel
 - User's Guide
 - CardioVascular
 - Gases
 - Metabolism
 - Hormones
 - Nerves
 - Setup
 - Status
 - Water
 - Proteins
 - Electrolytes
 - Heat
 - Physiomodel_Main
 - Substances

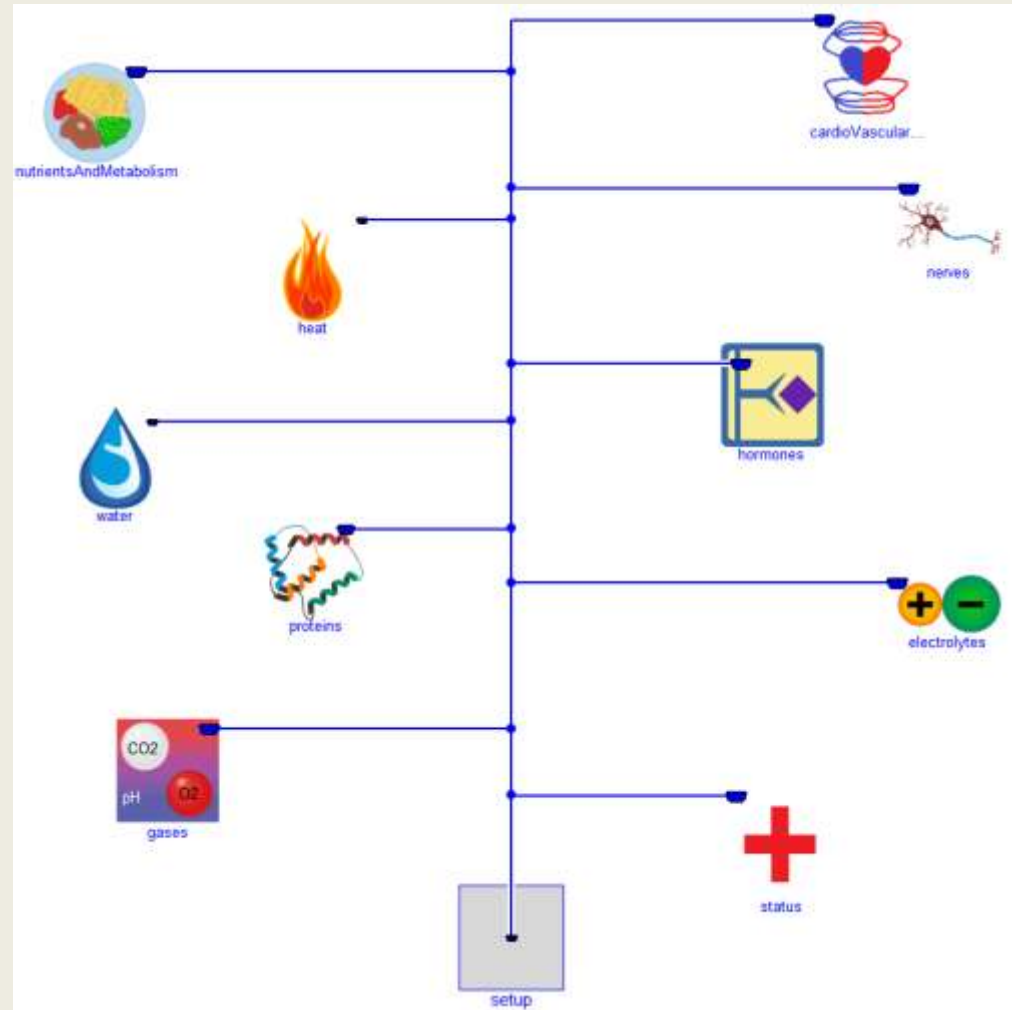

References

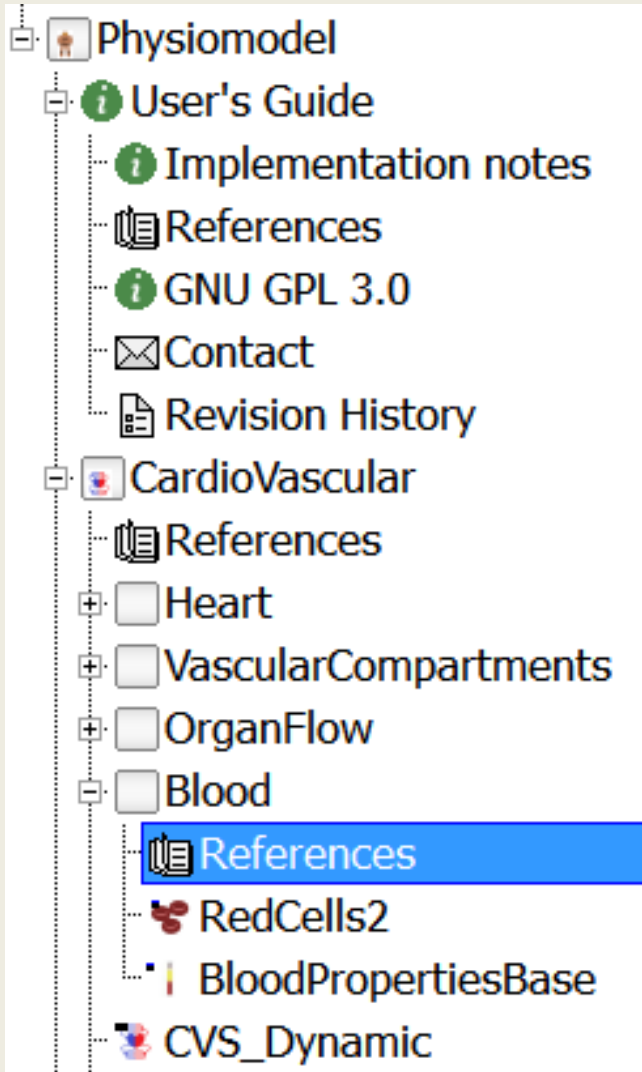

```
class References "References"  
  extends Modelica.Icons.References;  
  
  annotation (Documentation(info="<html>  
    <table>  
      <tr>  
        <td>[Begg1966]</td>  
        <td>T. Begg and J. Hearn, \"Comp  
          onents in blood viscosity. The relative contrib  
          ution of haematocrit, plasma fibrinogen and ot  
          her proteins,\" Clinical science, vol. 31, pp. 87  
          -93, 1966. </td>  
      </tr>  
    </table>  
    </html>"));  
end References;
```

Expandable connector

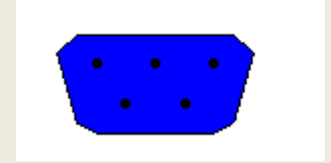

expandable connector BusConnector

"Empty control bus that is adapted to the signals connected to it"

annotation (Documentation(info="<html>

<p>

This connector defines the \"expandable connector\" that is used as bus in the Physiomodel.

Note, this connector is \"empty\". When using it, the actual content is constructed by the signals connected to this bus.

</p>

</html>"));

end BusConnector;

Input-Output Bus

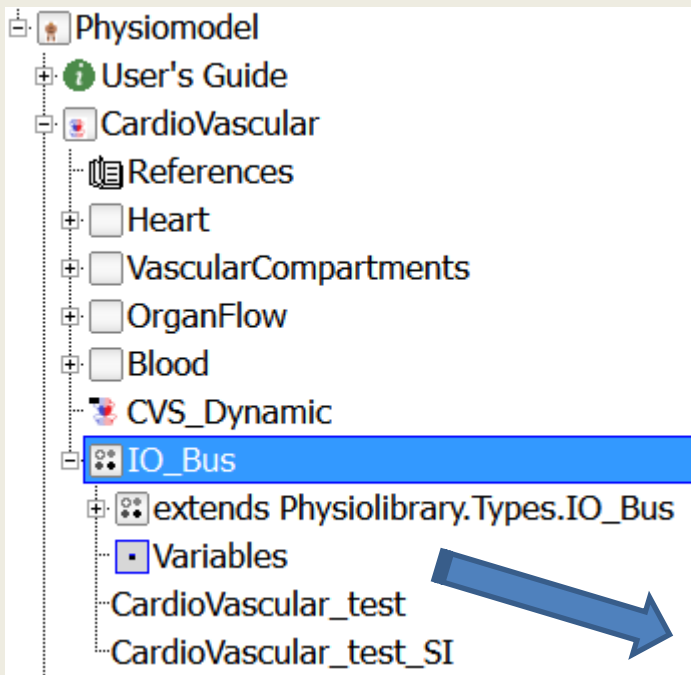

```
package IO_Bus  
extends Physioblibrary.Types.IO_Bus;
```

```
redeclare model extends Variables
```

```
  T.Volume ArtysVol(varName="ArtysVol.Vol")  
    "Volume of oxygenated blood in body."  
  T.Fraction BloodVol_Hct(varName="BloodVol.Hct")  
    "Heamatocrit = red cells / blood.";
```

...

```
equation
```

```
  connect(ArtysVol.y, busConnector.ArtysVol);  
  connect(BloodVol_Hct.y, busConnector.BloodVol_Hct);
```

...

```
end Variables;
```

IO_Bus usage

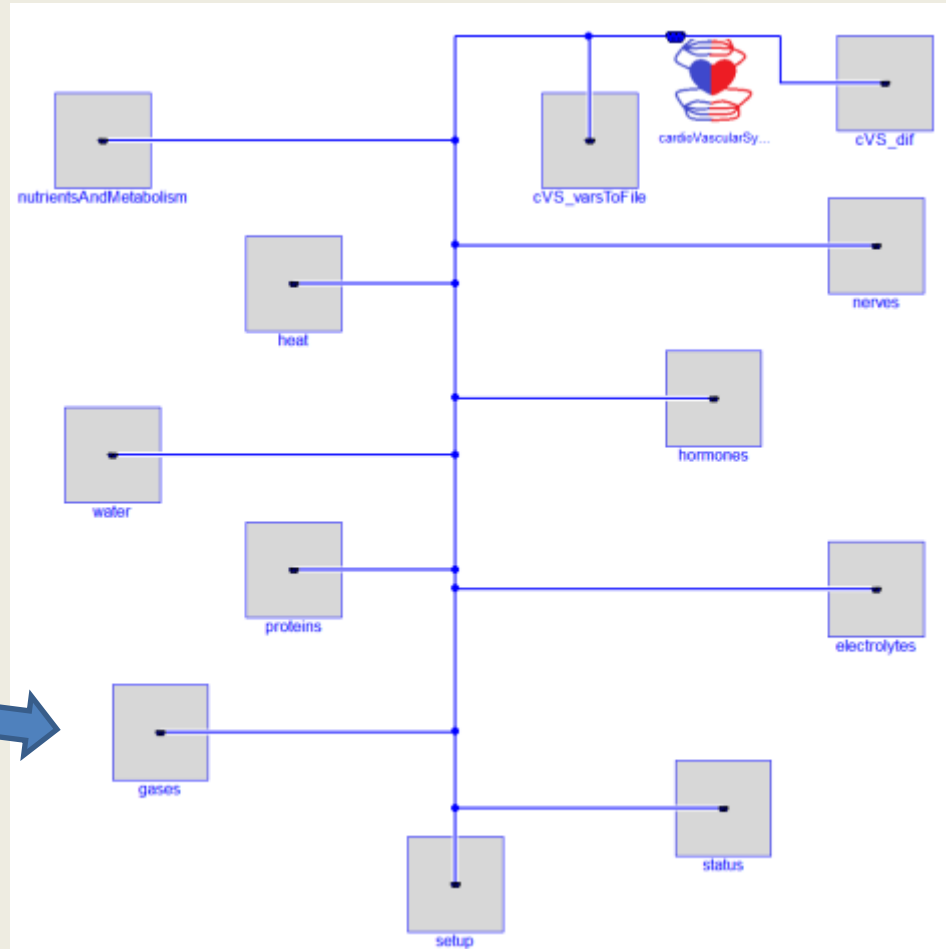
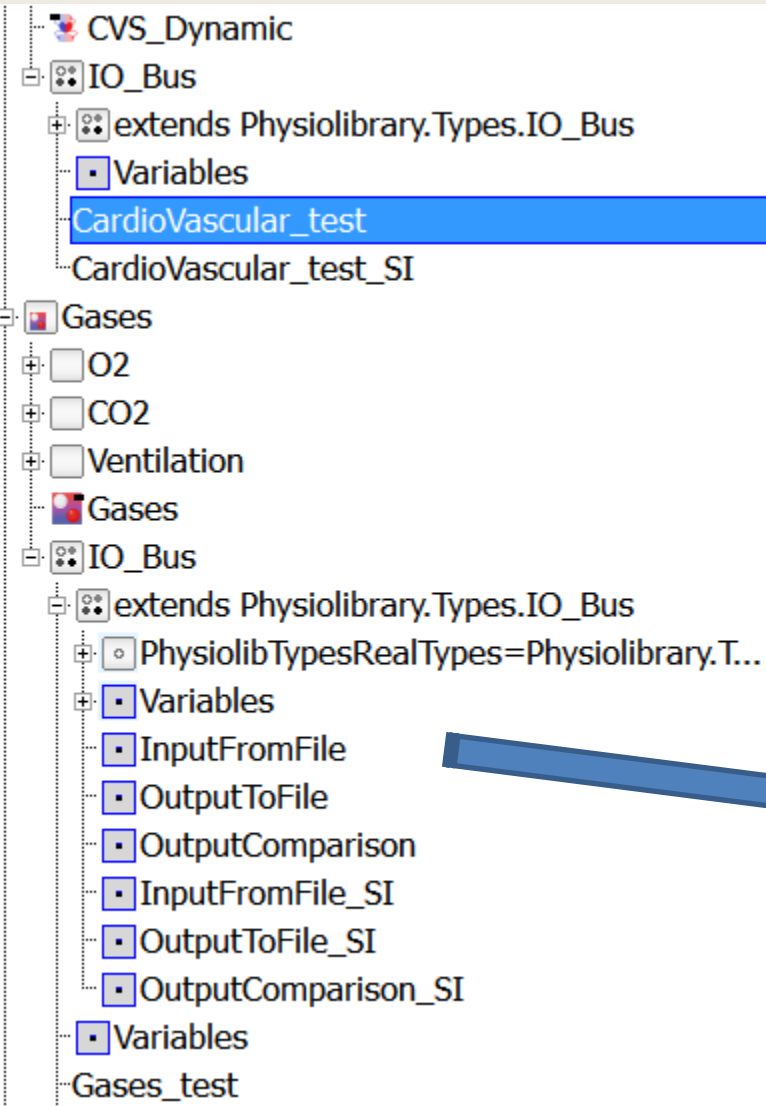

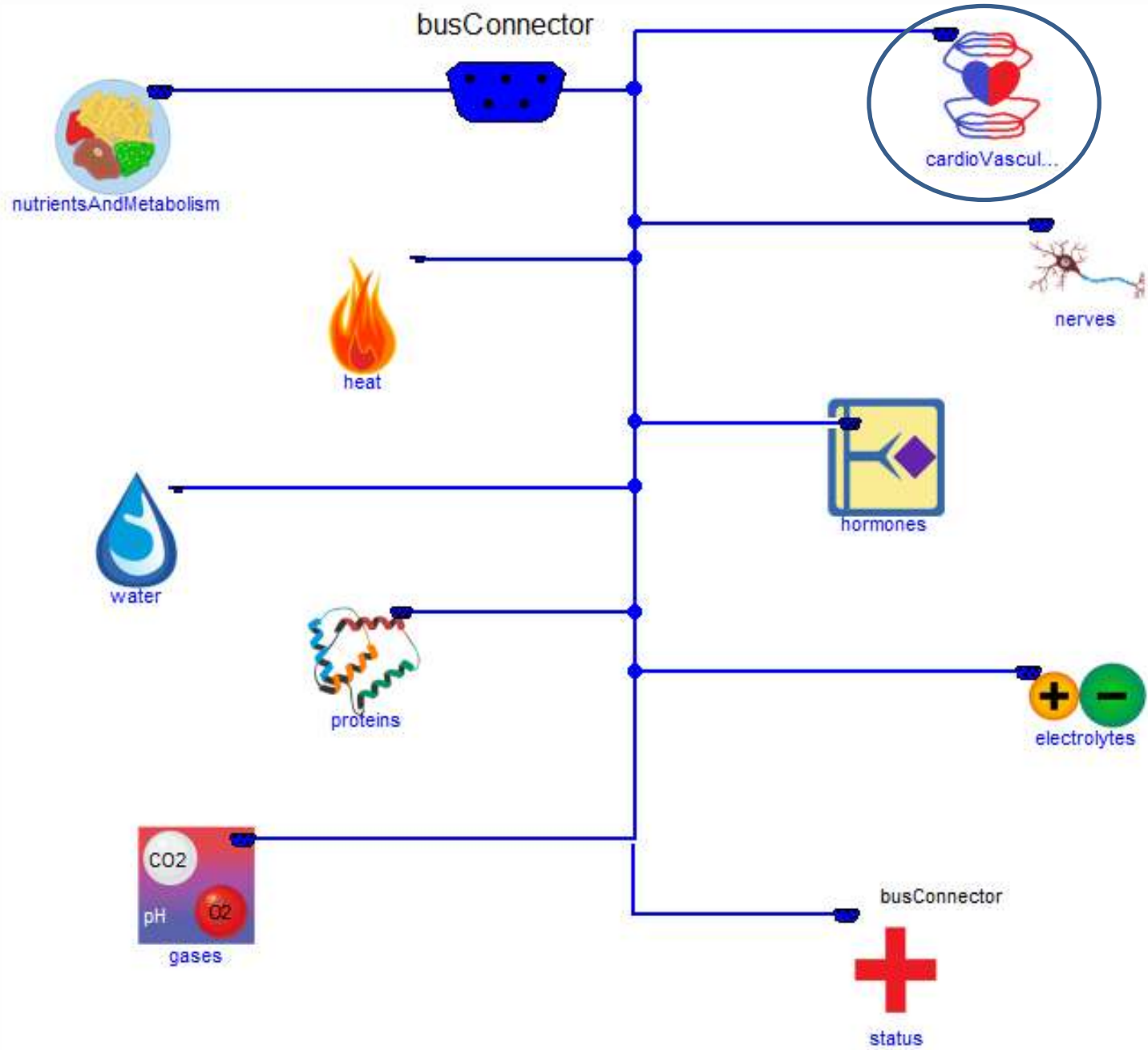

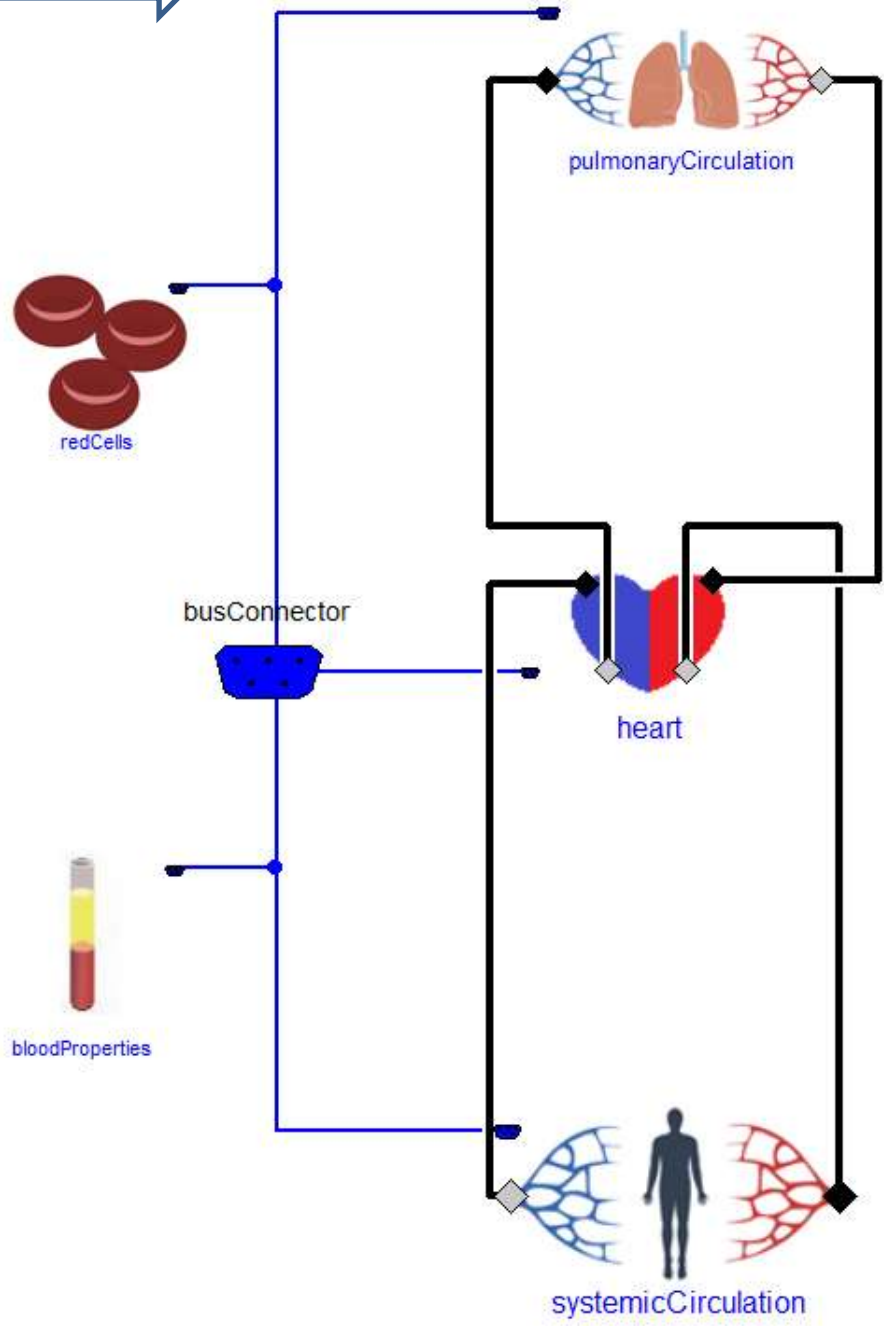
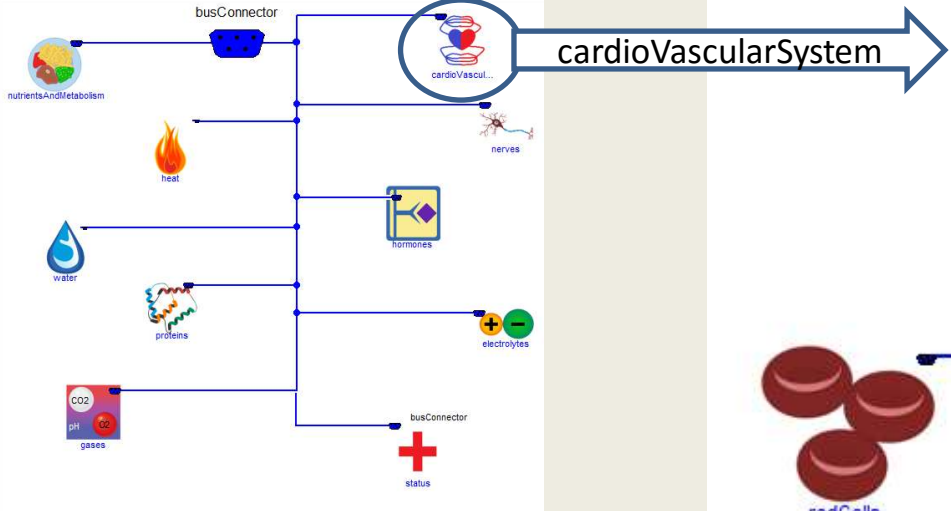

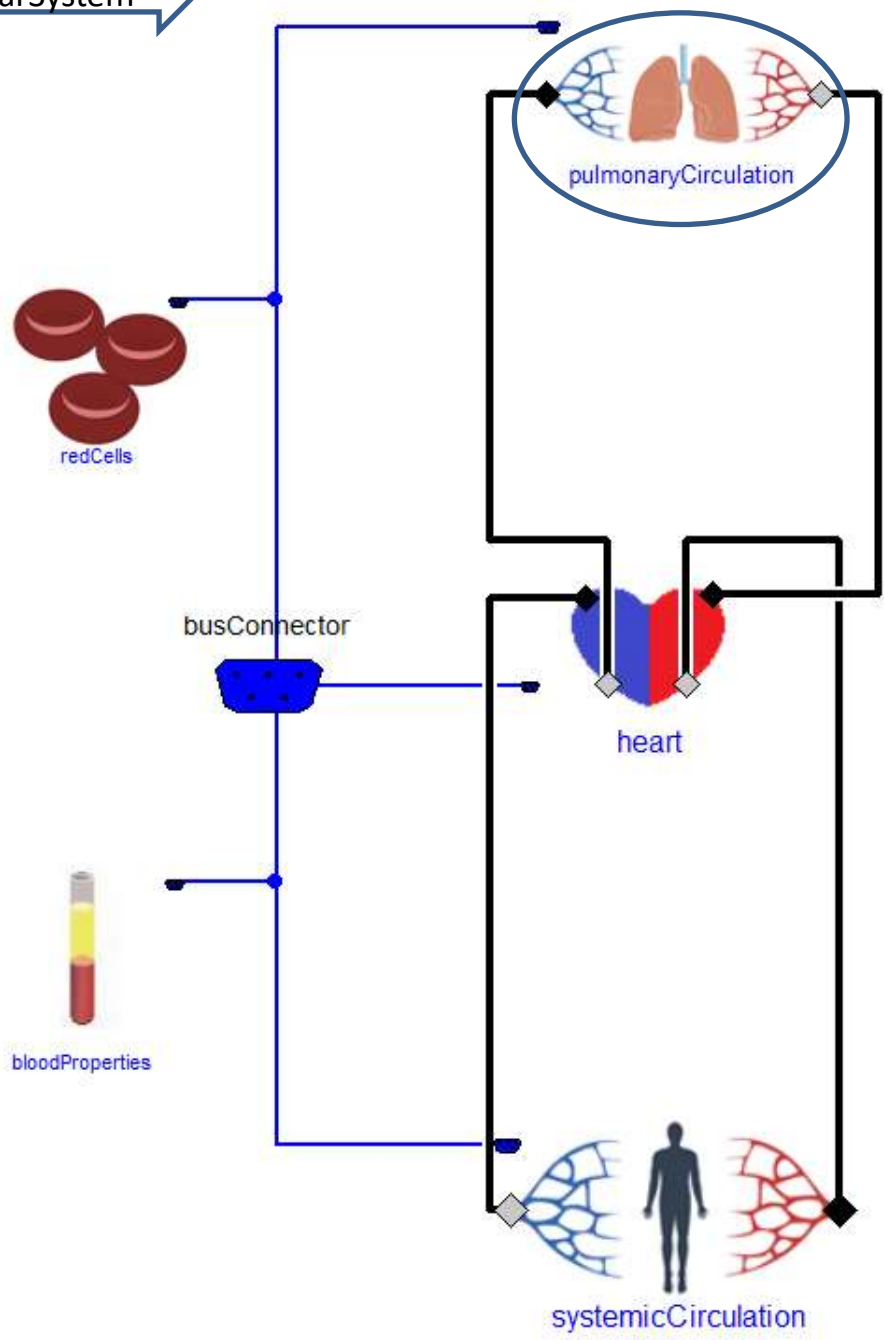
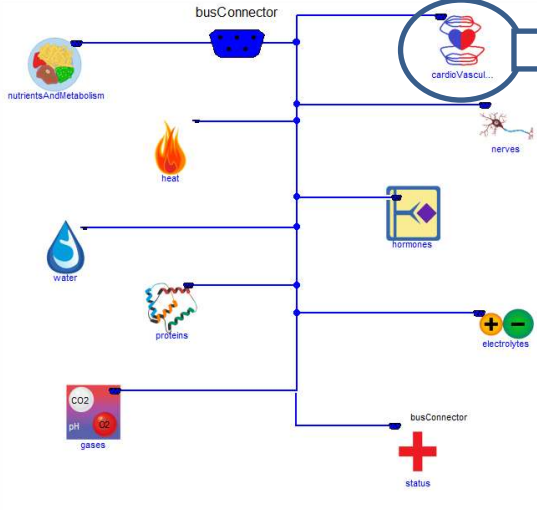

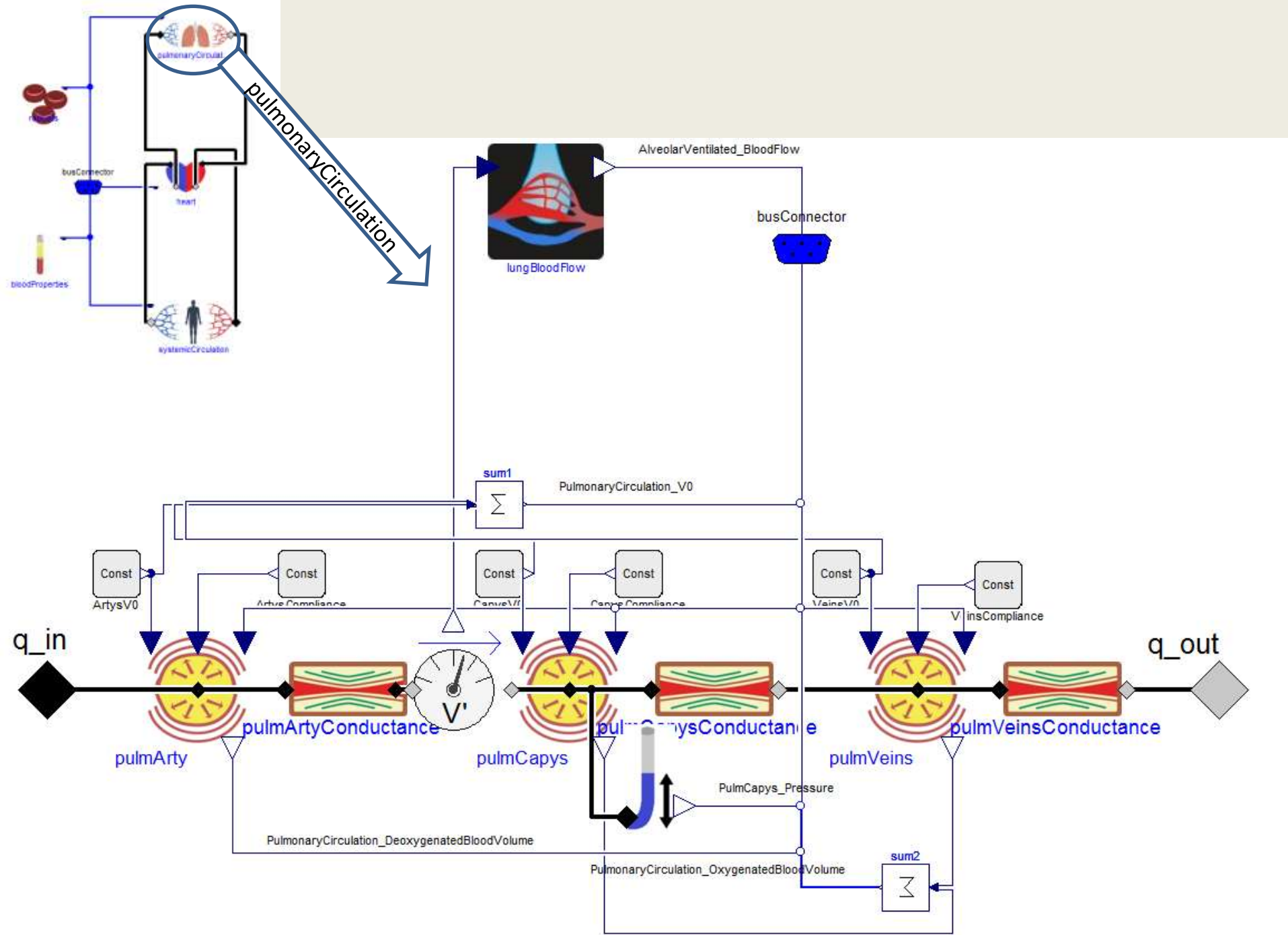

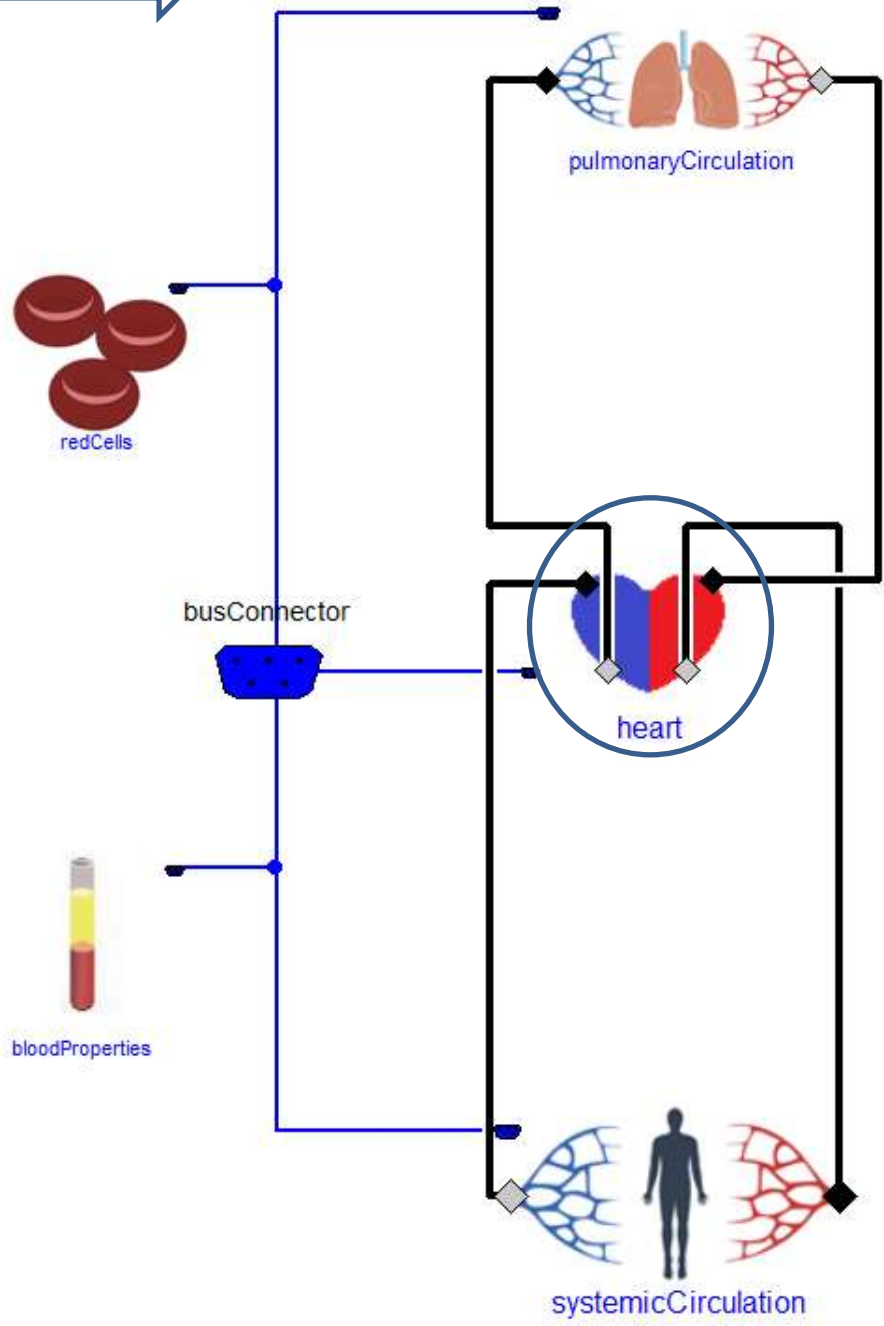
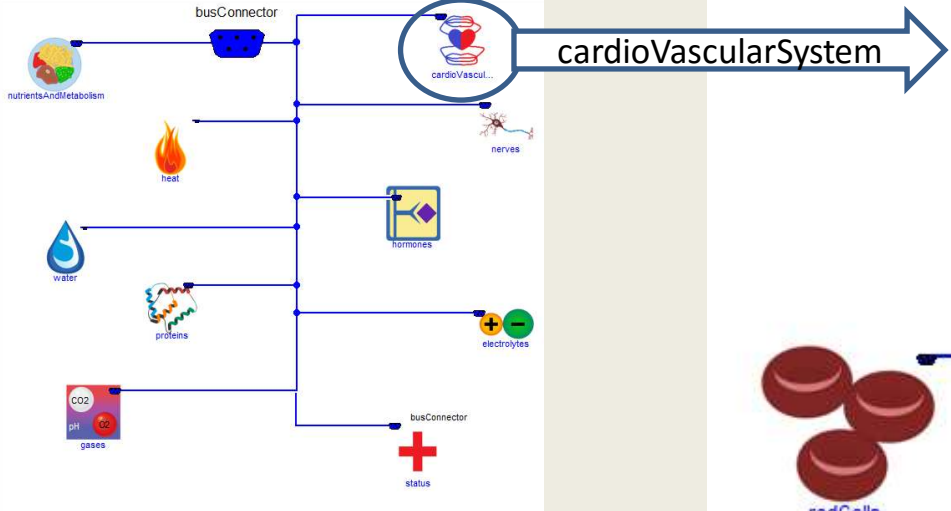

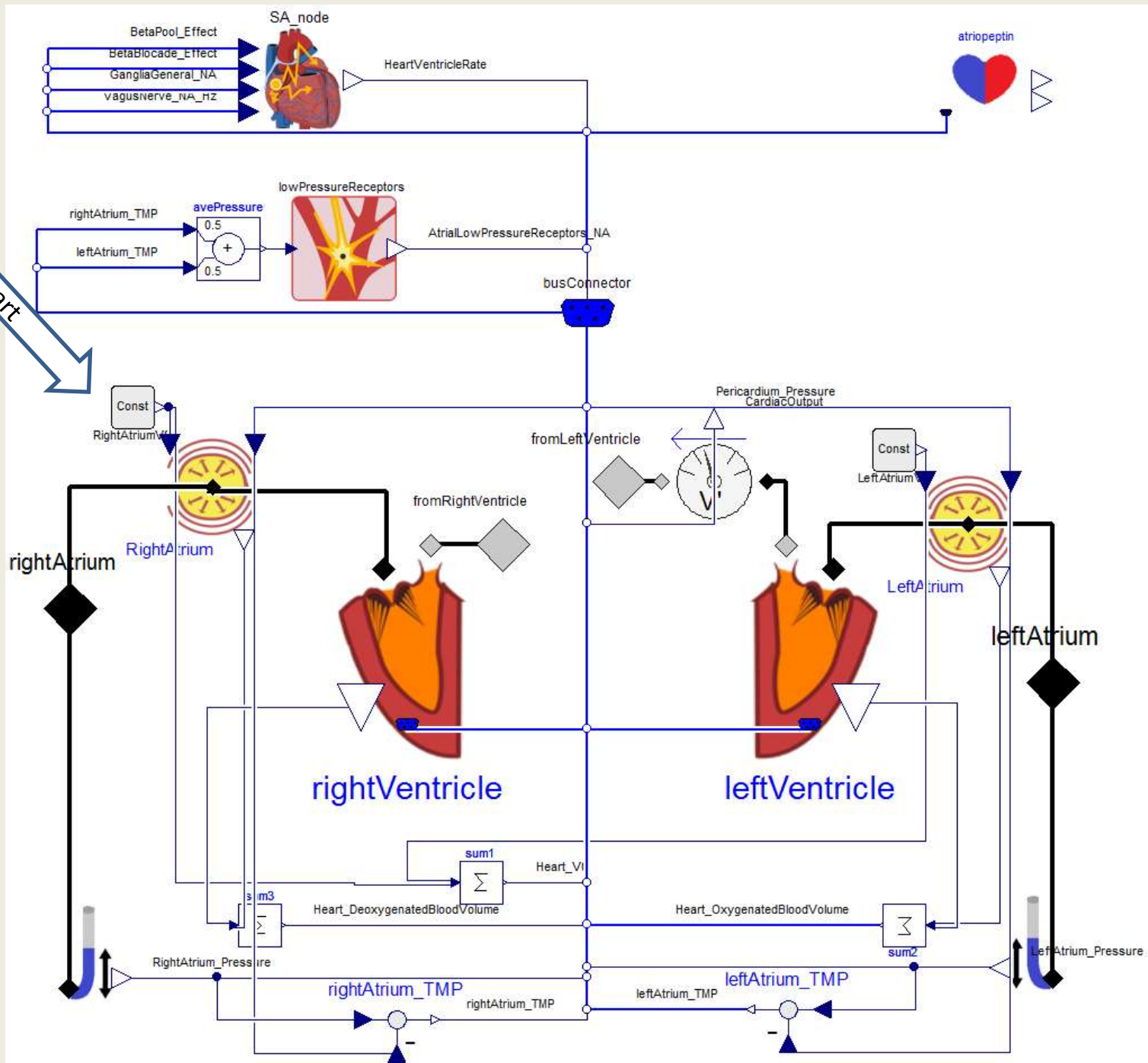
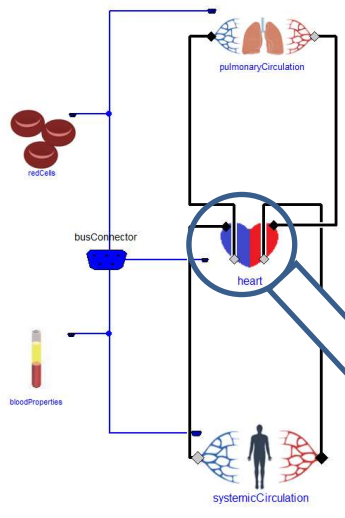

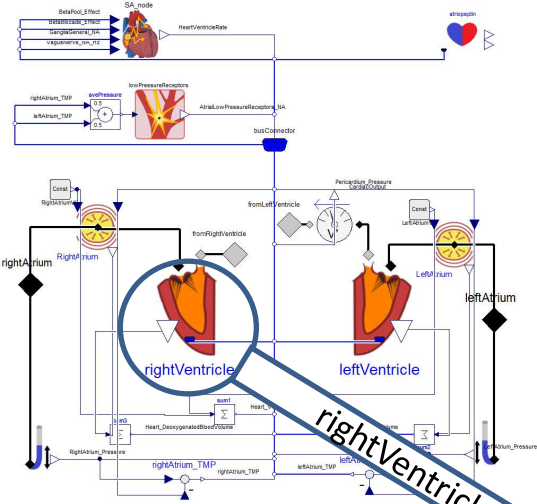

For rightVentricle and leftVentricle:
the instances of the same class with different parameters

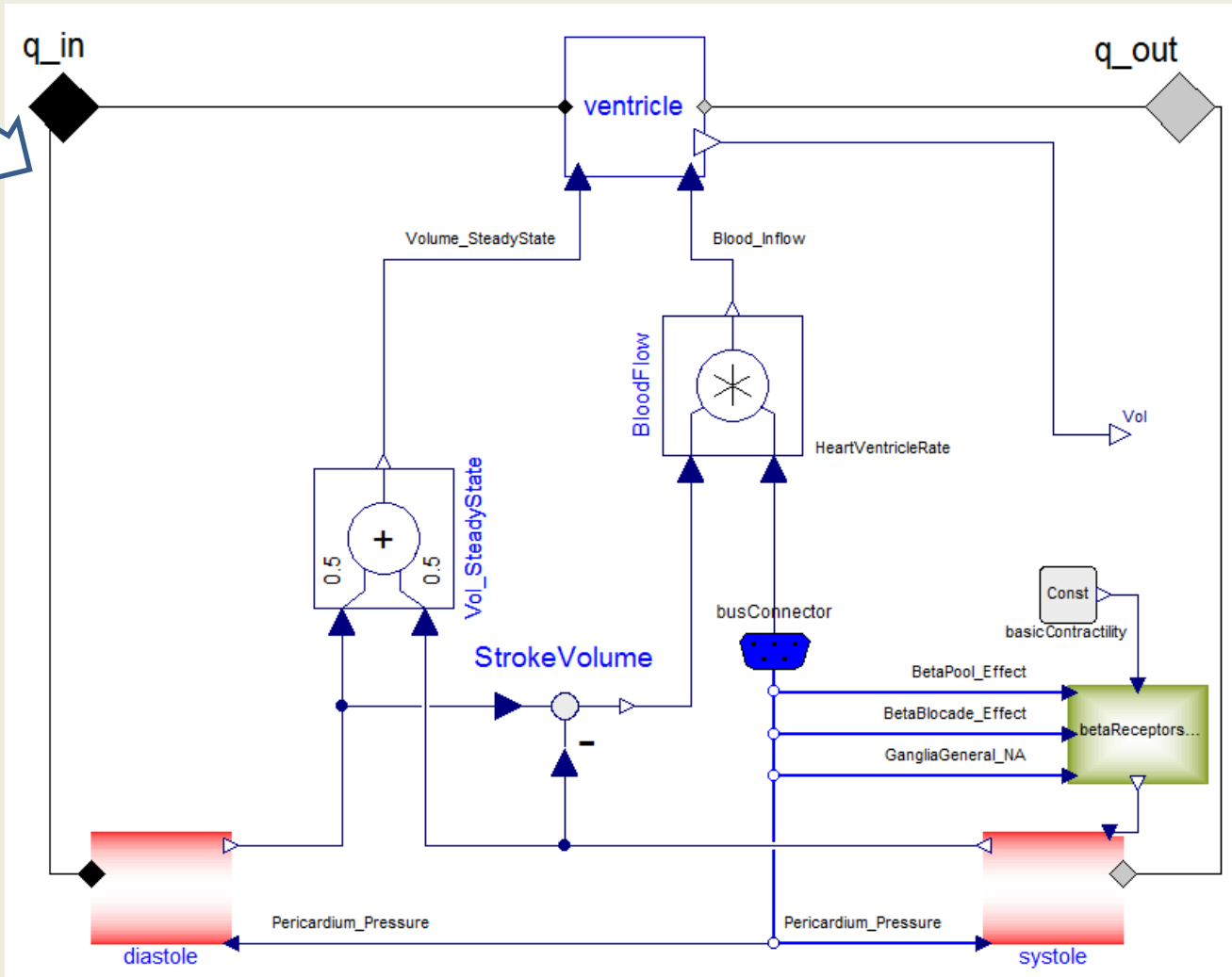

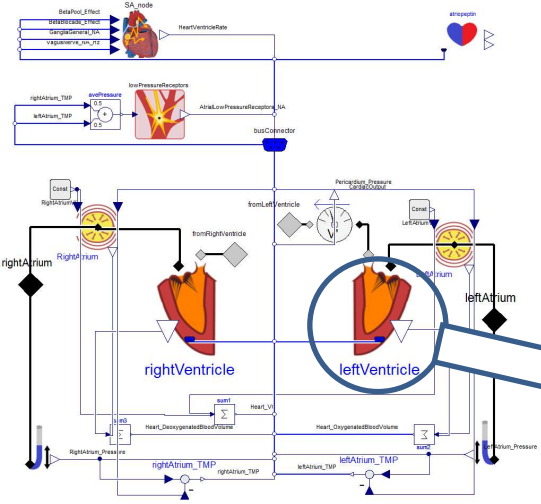

For rightVentricle and leftVentricle:
the instances of the same class with different parameters

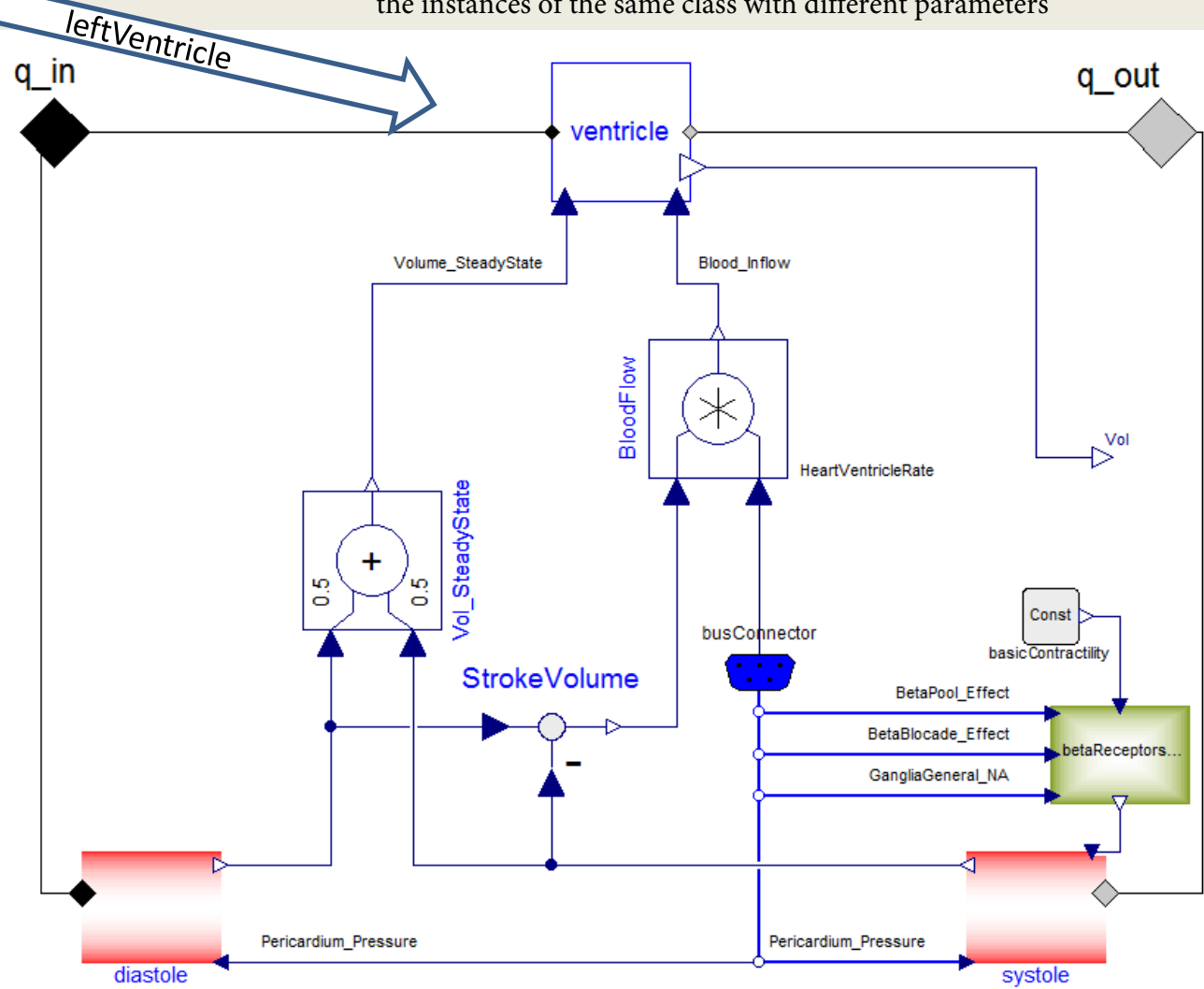

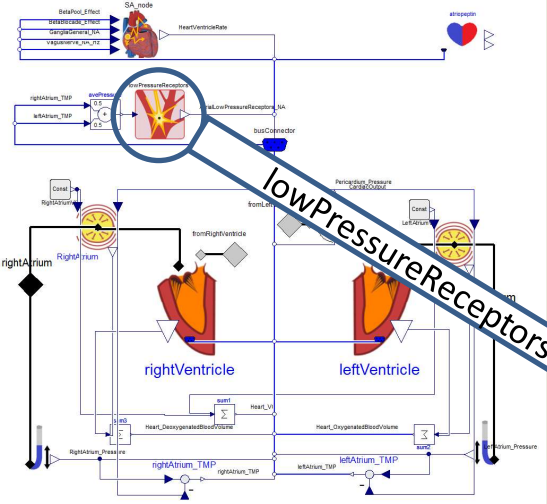

lowPressureReceptors

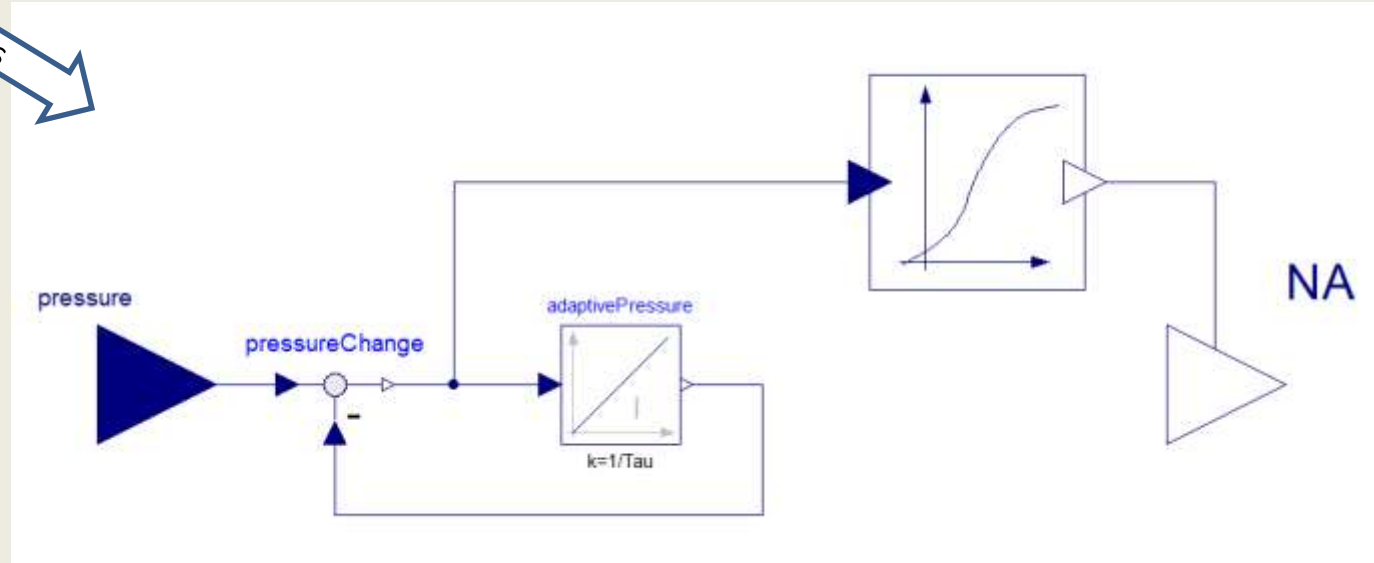

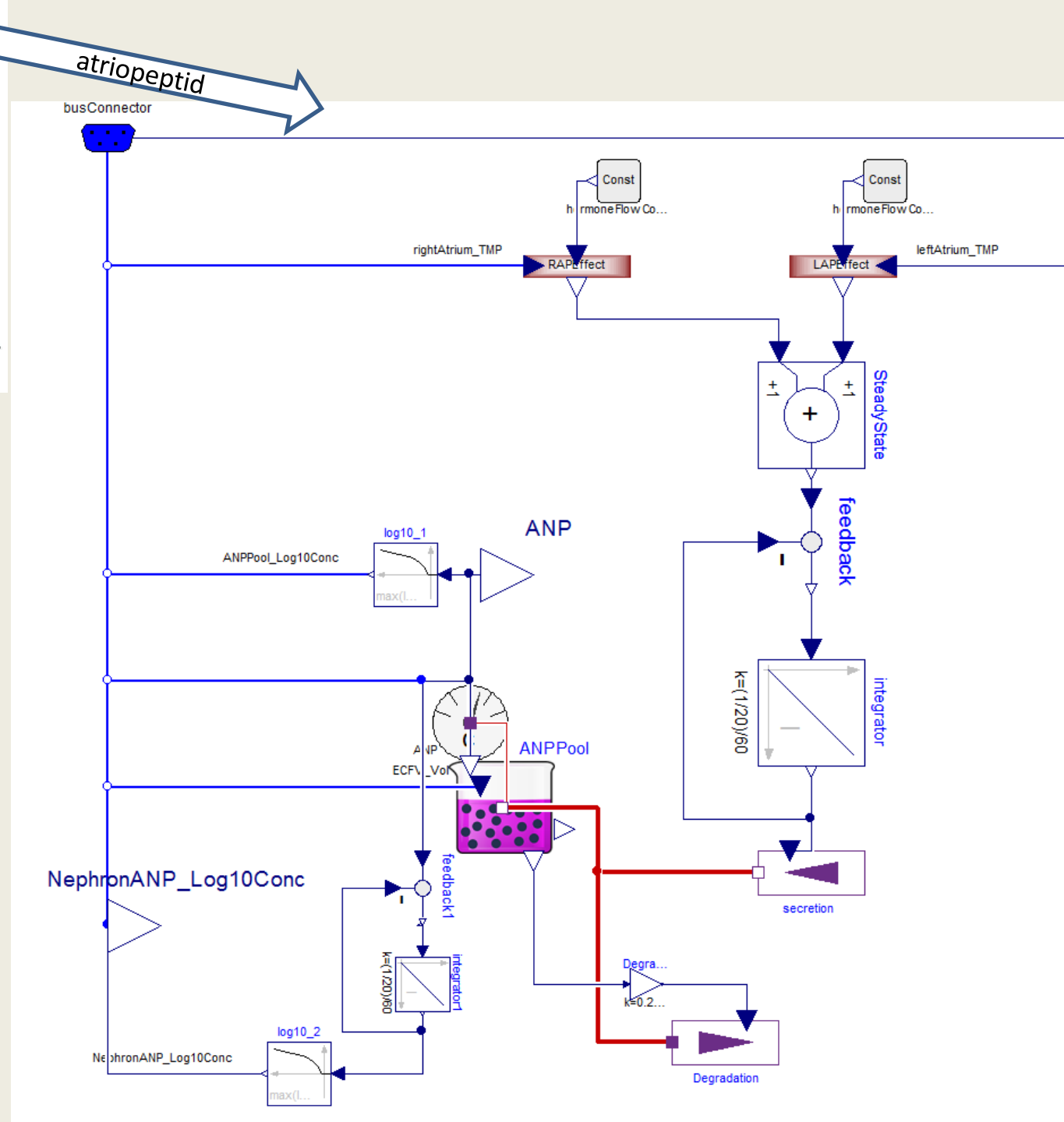
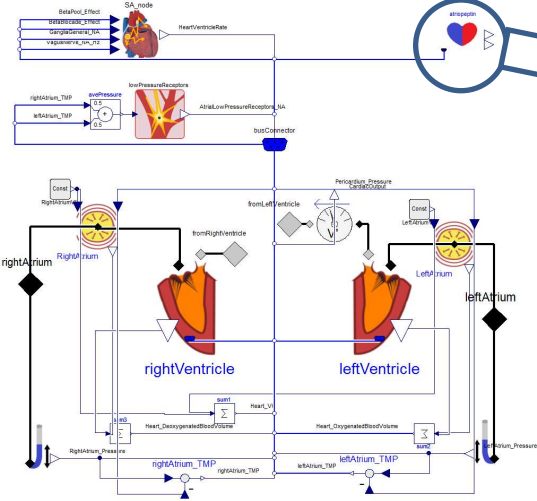

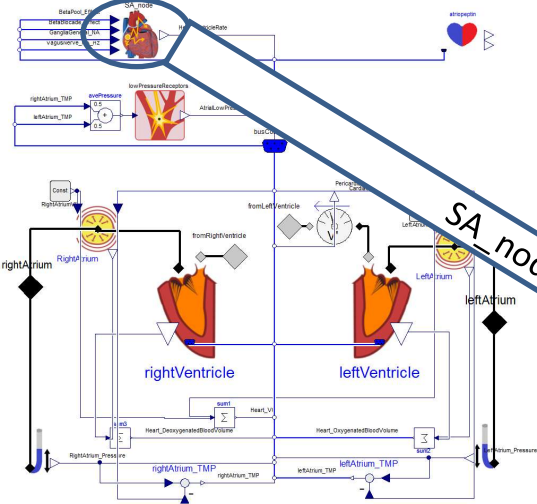

SA_node

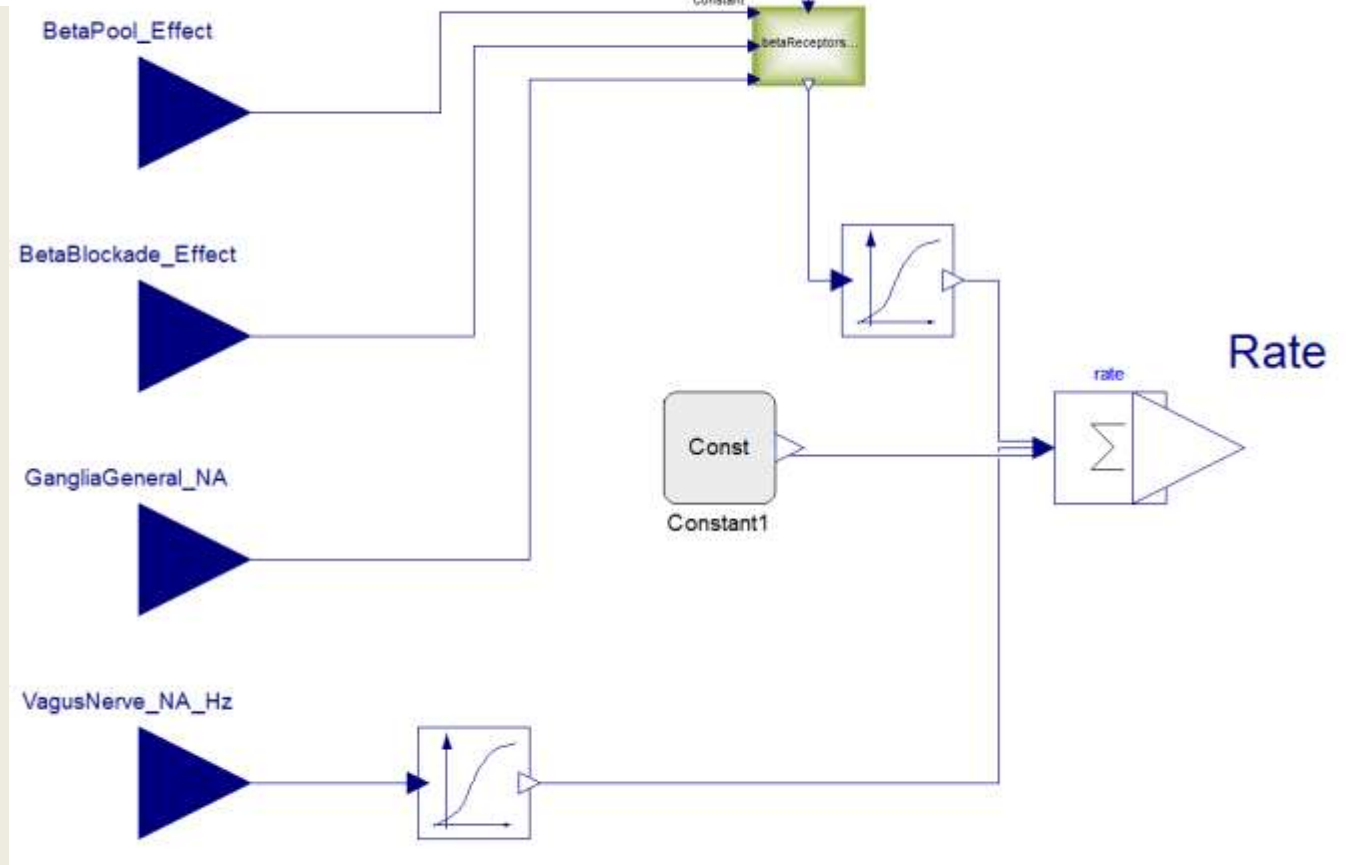

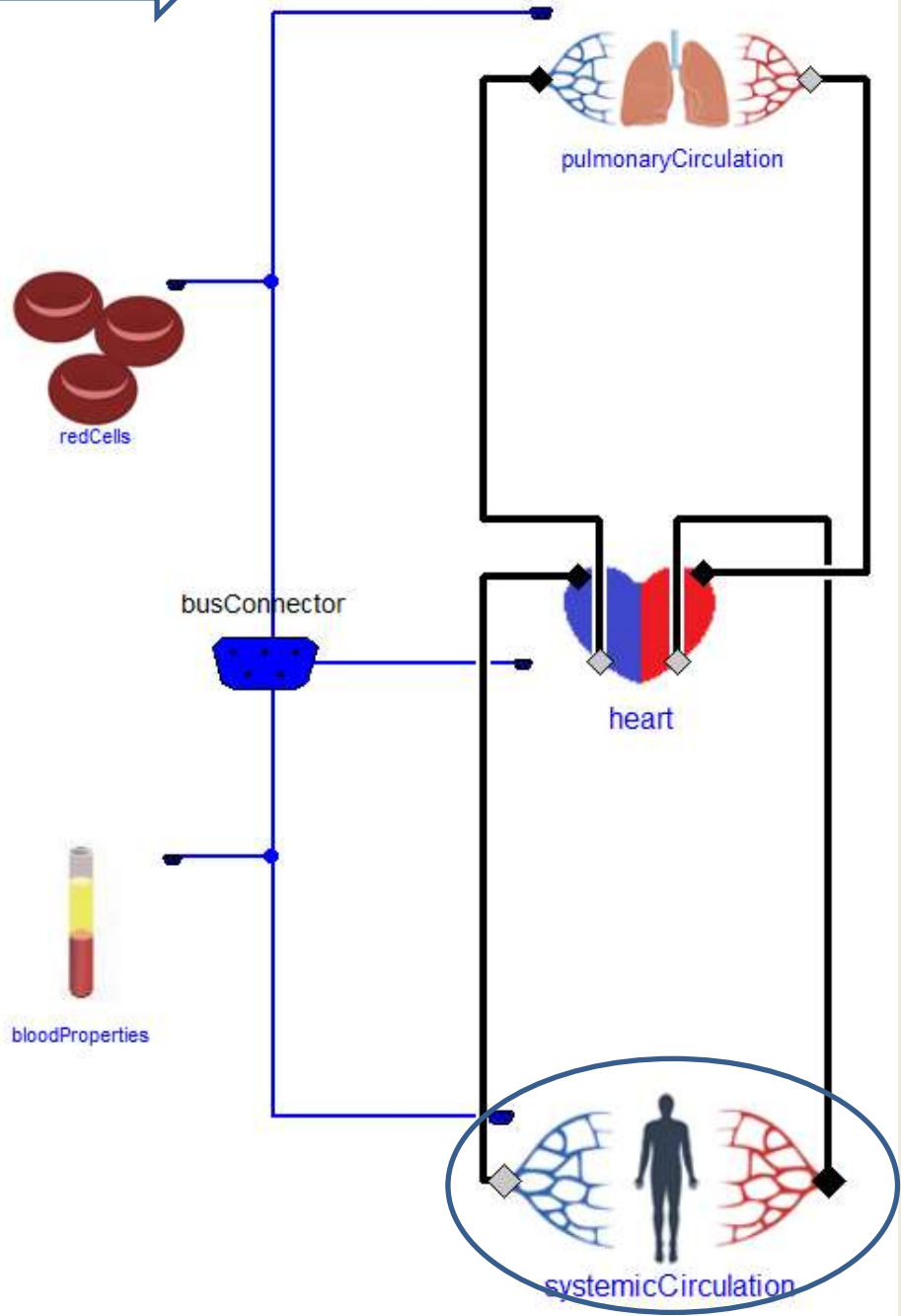
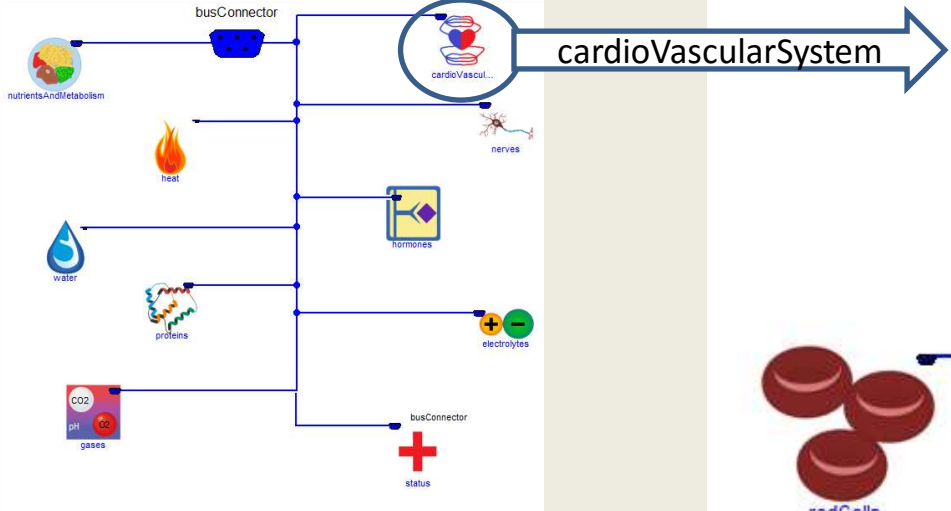

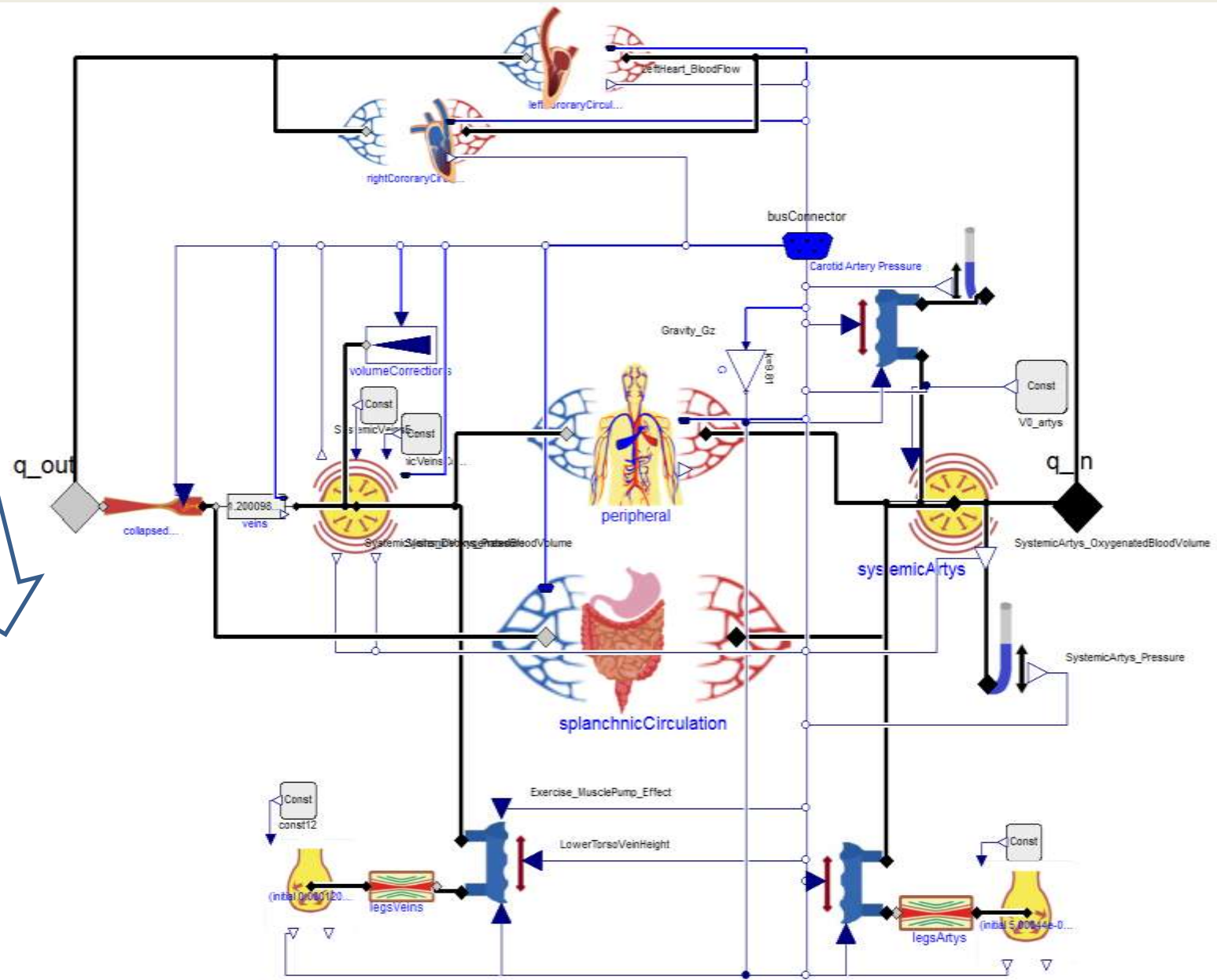
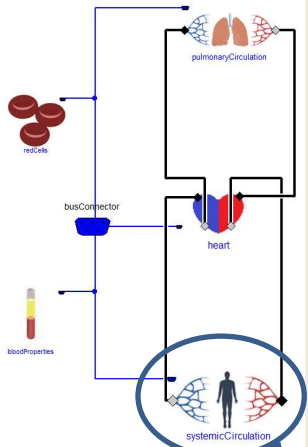

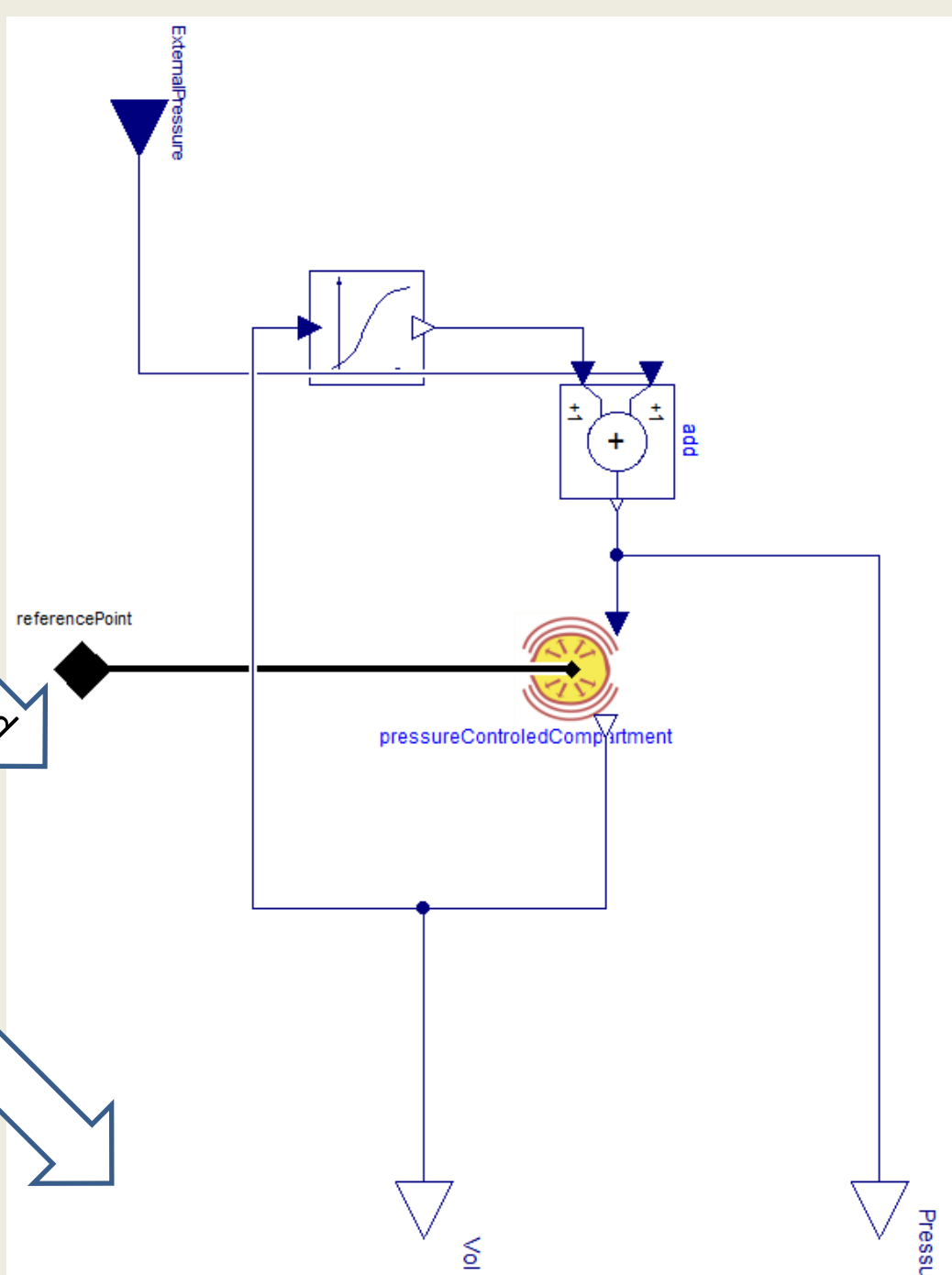
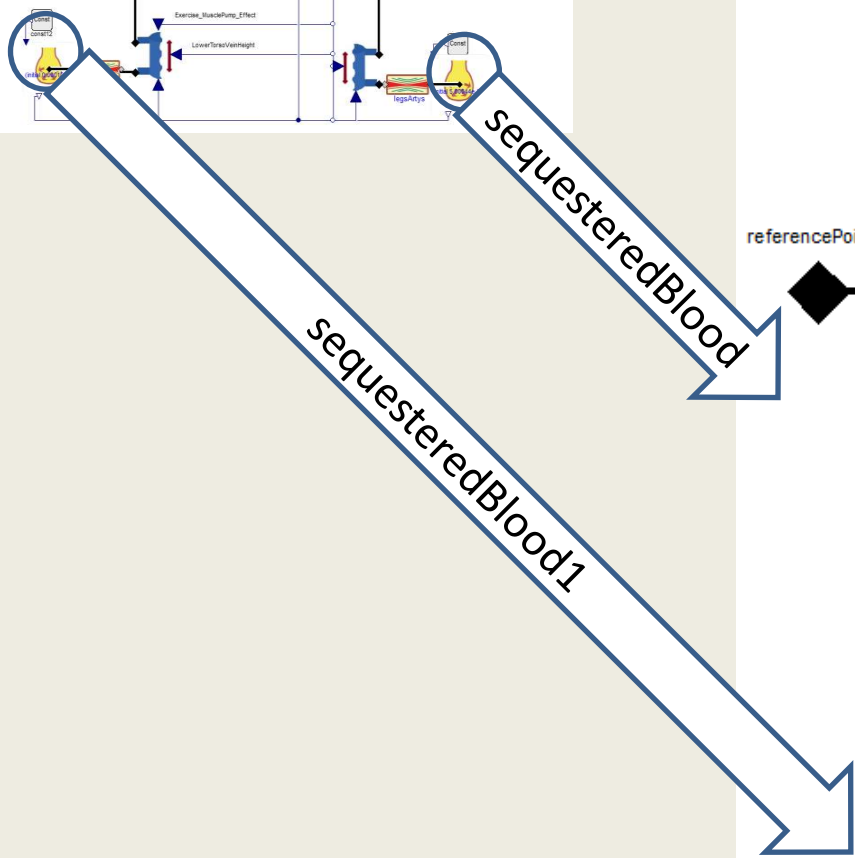
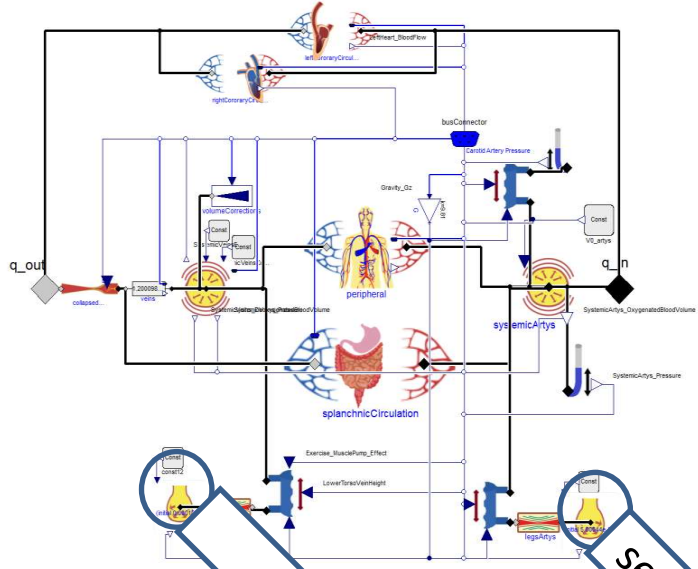

The instances of the same class with different parameters

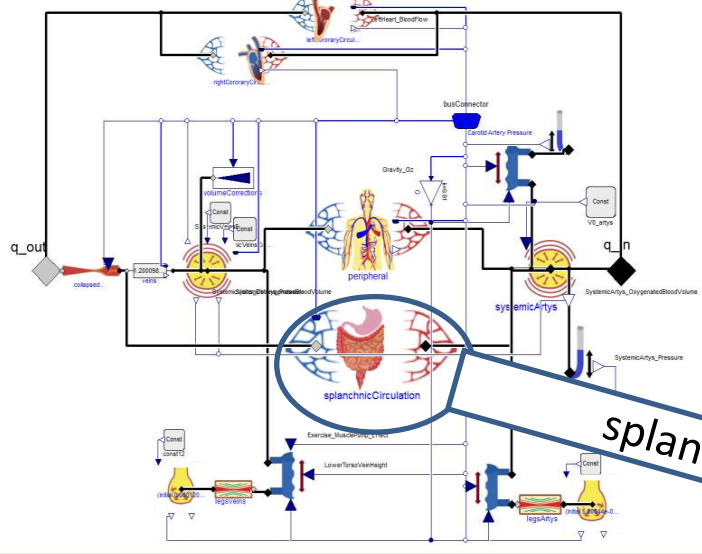

splanchnicCirculation

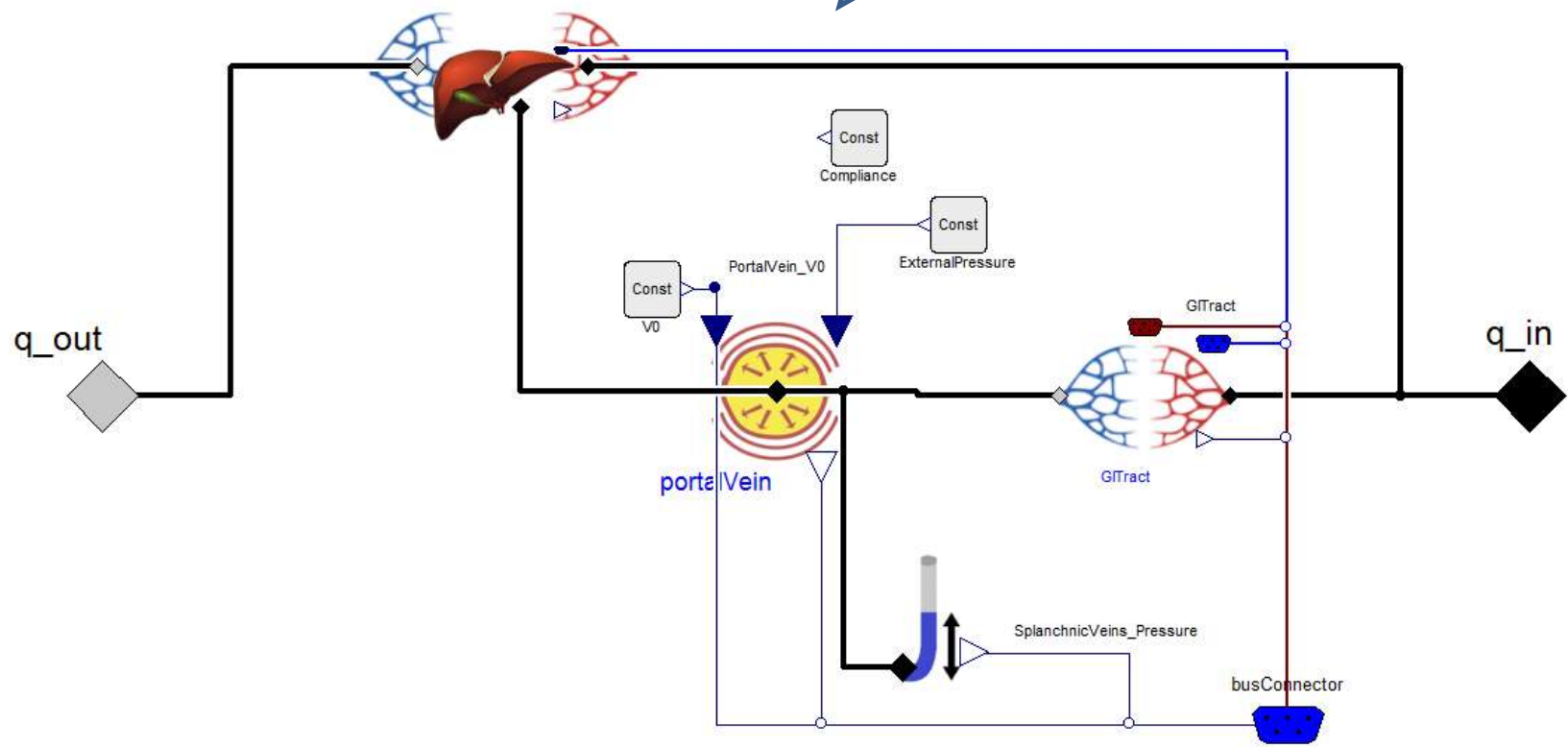

For GItract, bone, brain, fat, skeletalMuscle, respiratoryMuscle, otherTissue:
the instances of the same class with different parameters

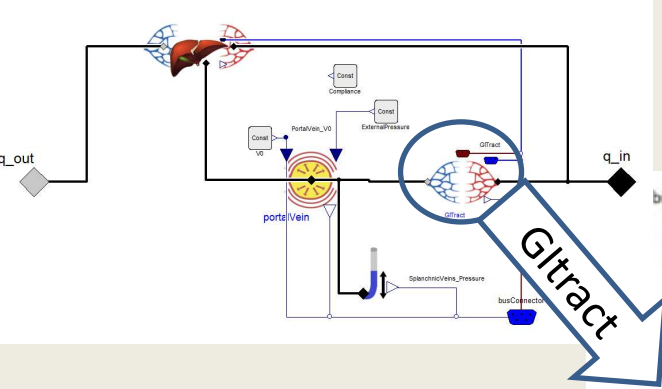

GItract

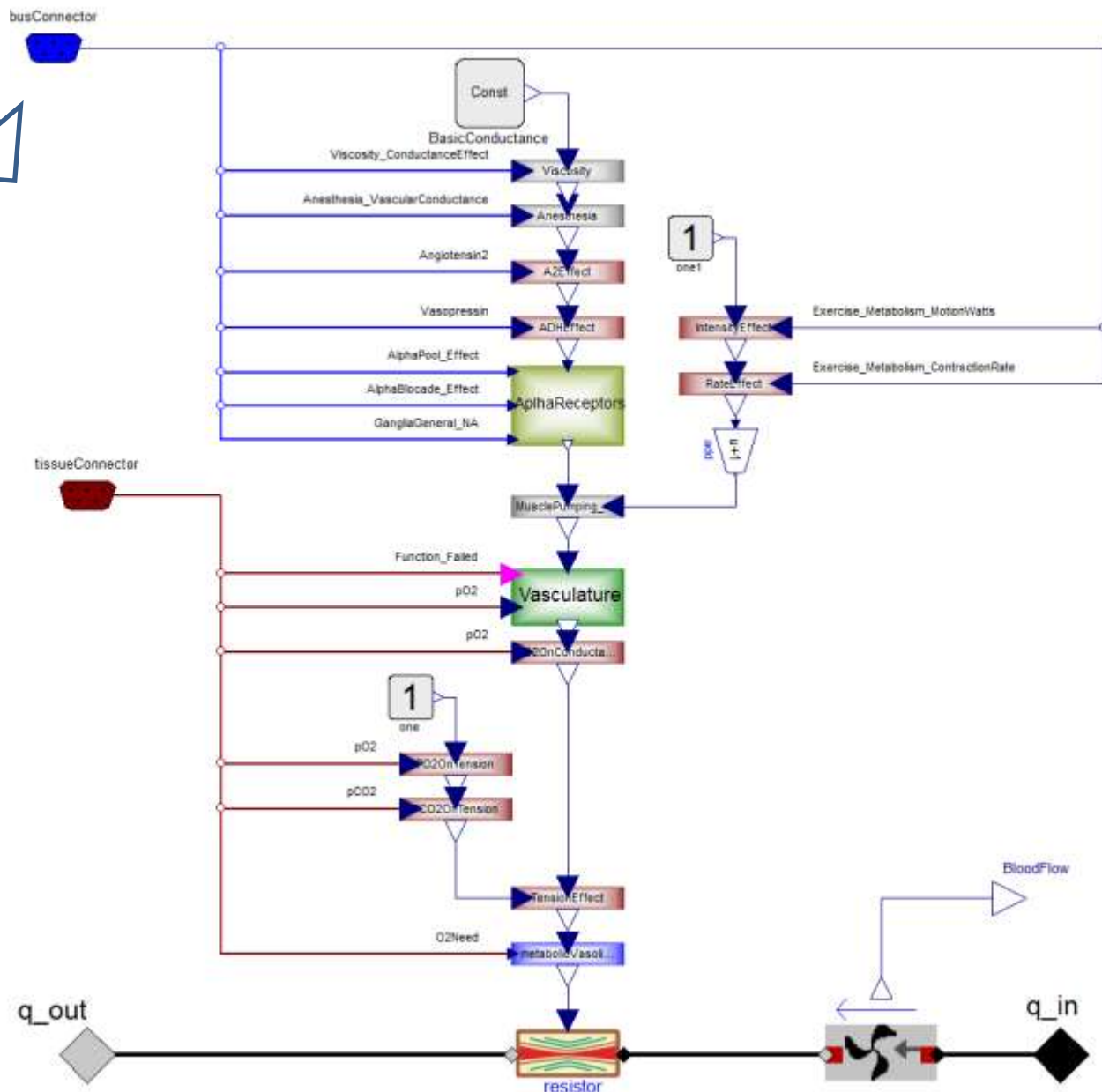

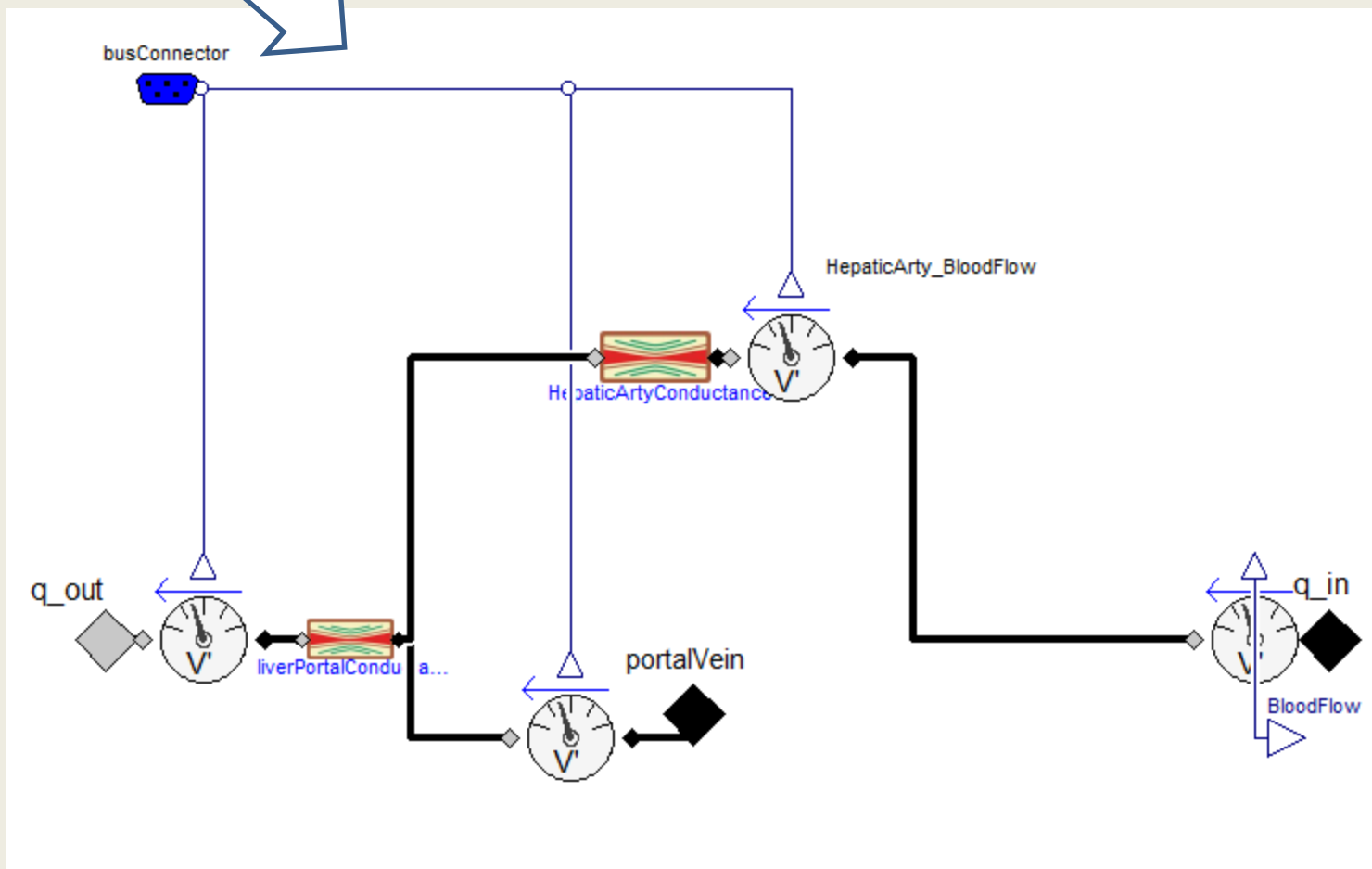
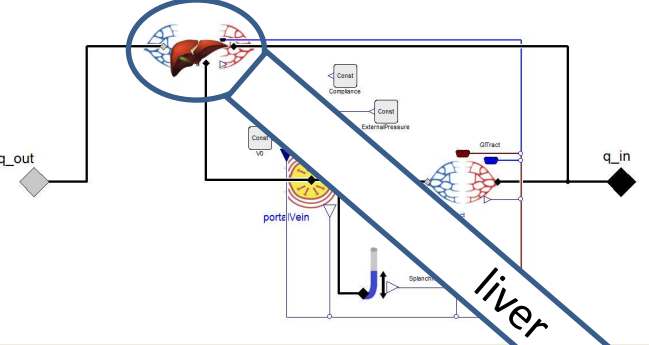

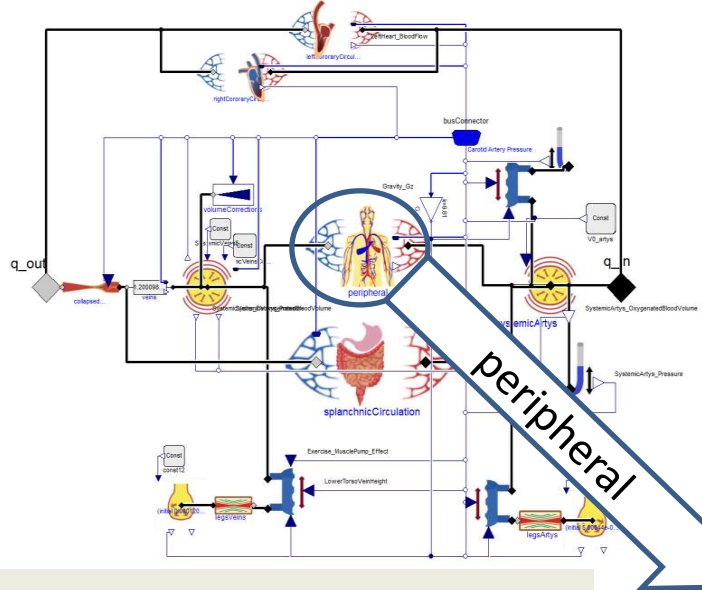

busConnector

q_out

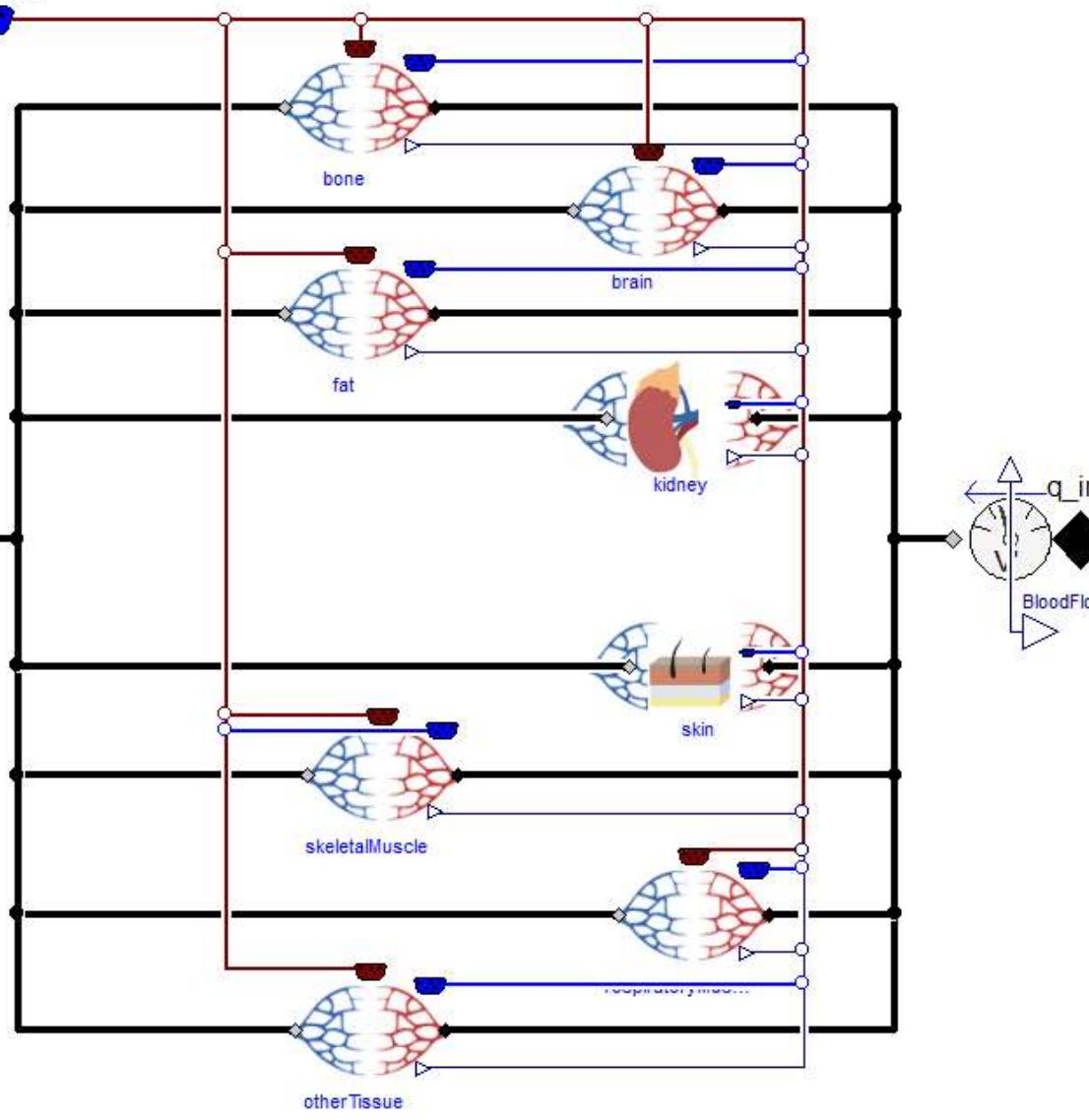

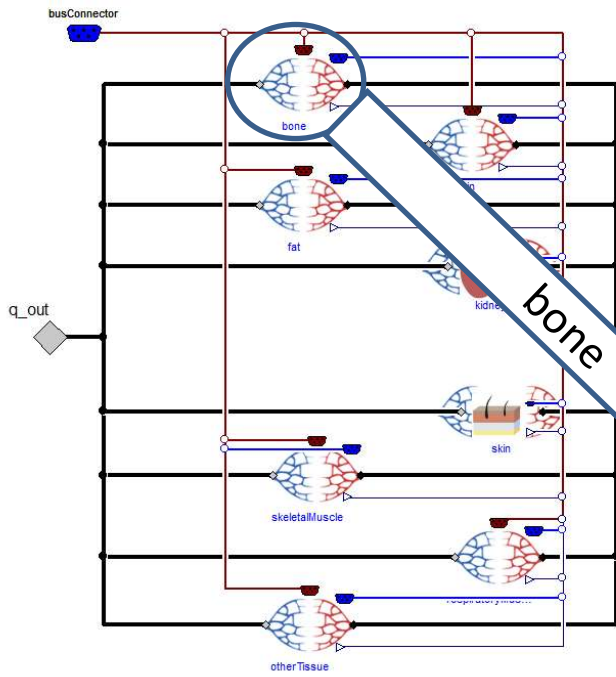

For GItract, bone, brain, fat, skeletalMuscle, respiratoryMuscle, otherTissue: the instances of the same class with different parameters

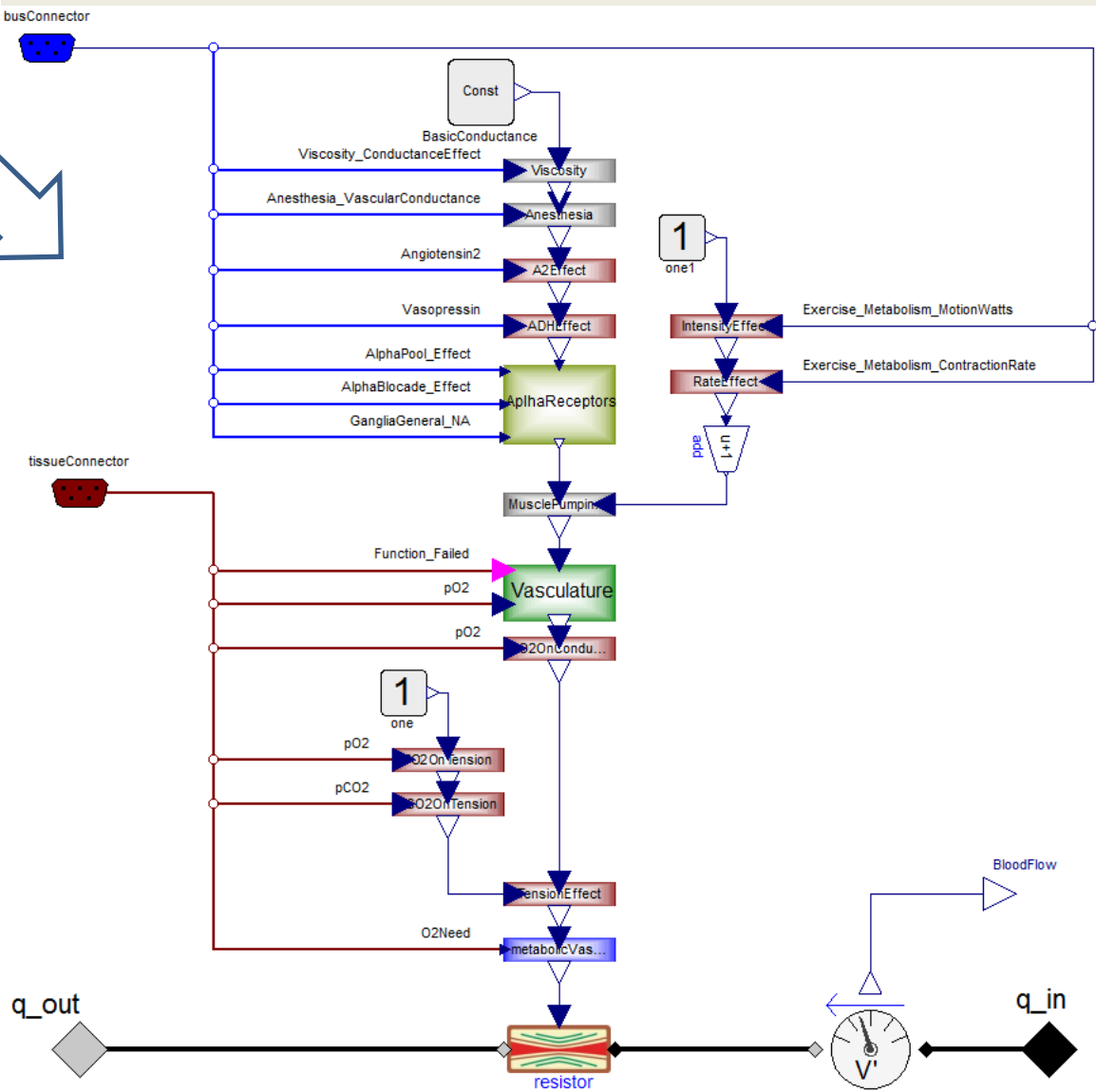

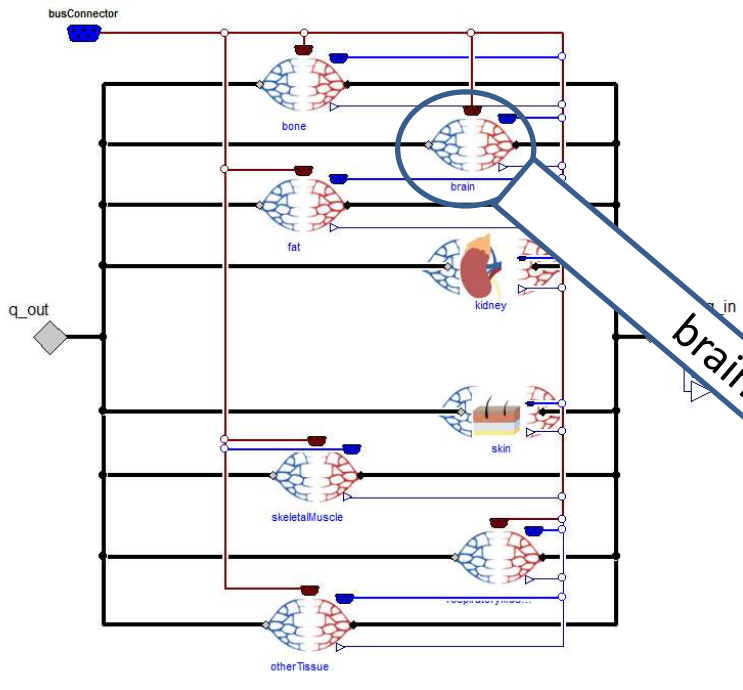

For GItract, bone, brain, fat, skeletalMuscle, respiratoryMuscle, otherTissue:
the instances of the same class with different parameters

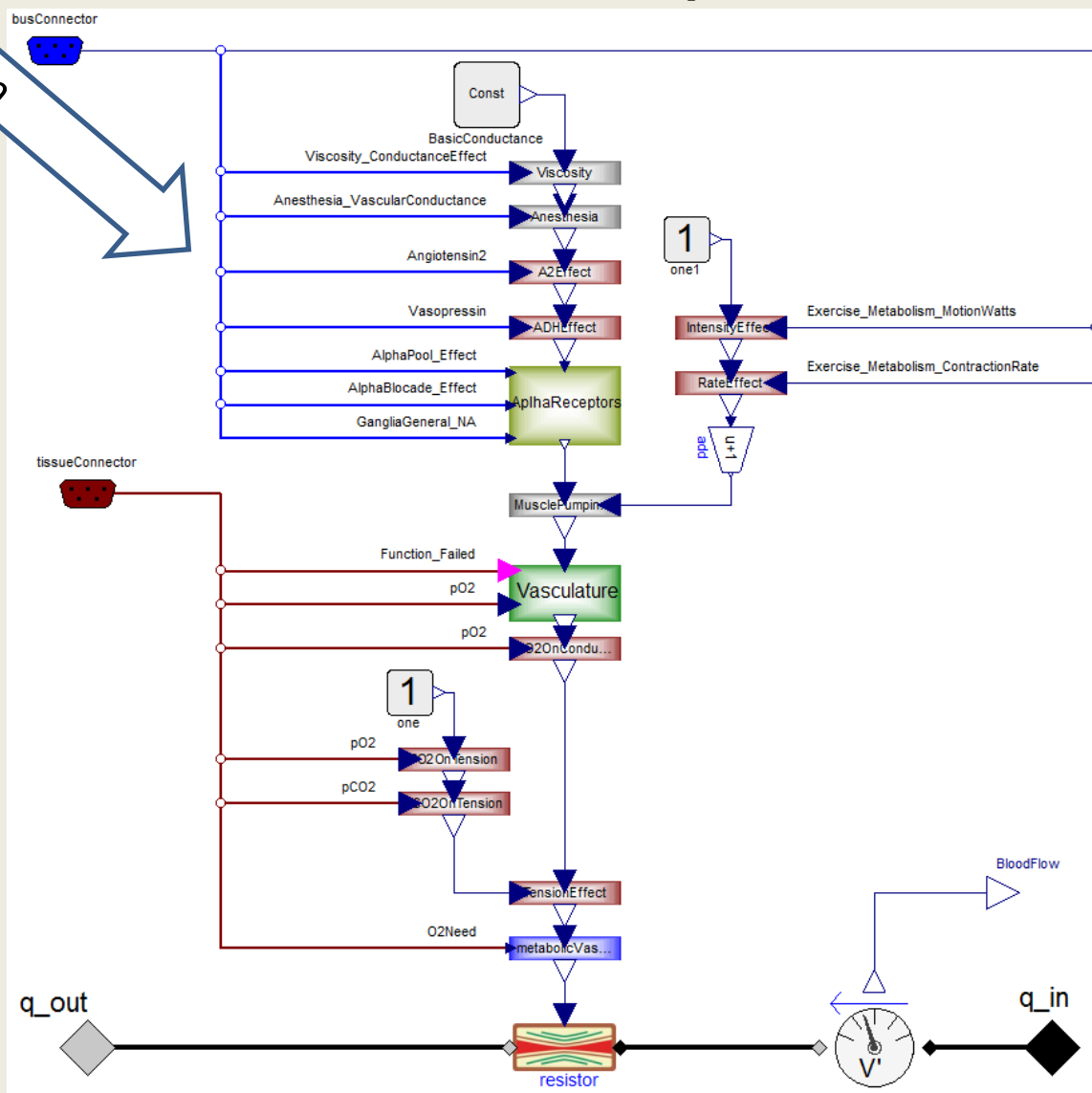

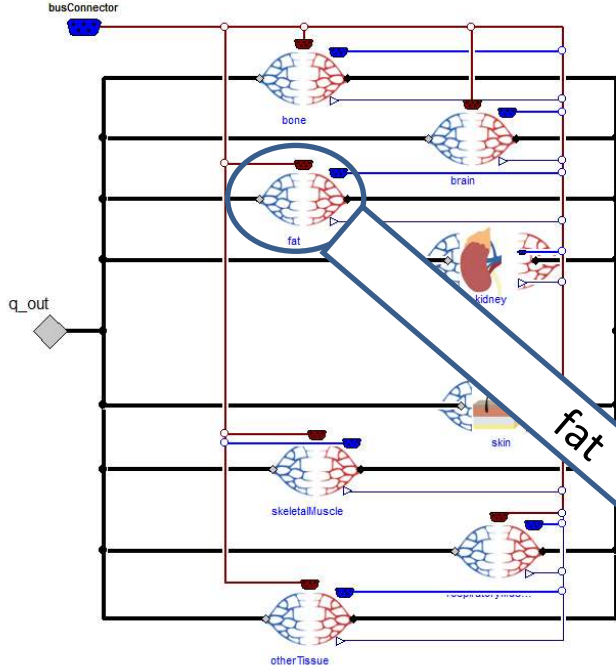

For GItract, bone, brain, fat, skeletalMuscle, respiratoryMuscle, otherTissue:
the instances of the same class with different parameters

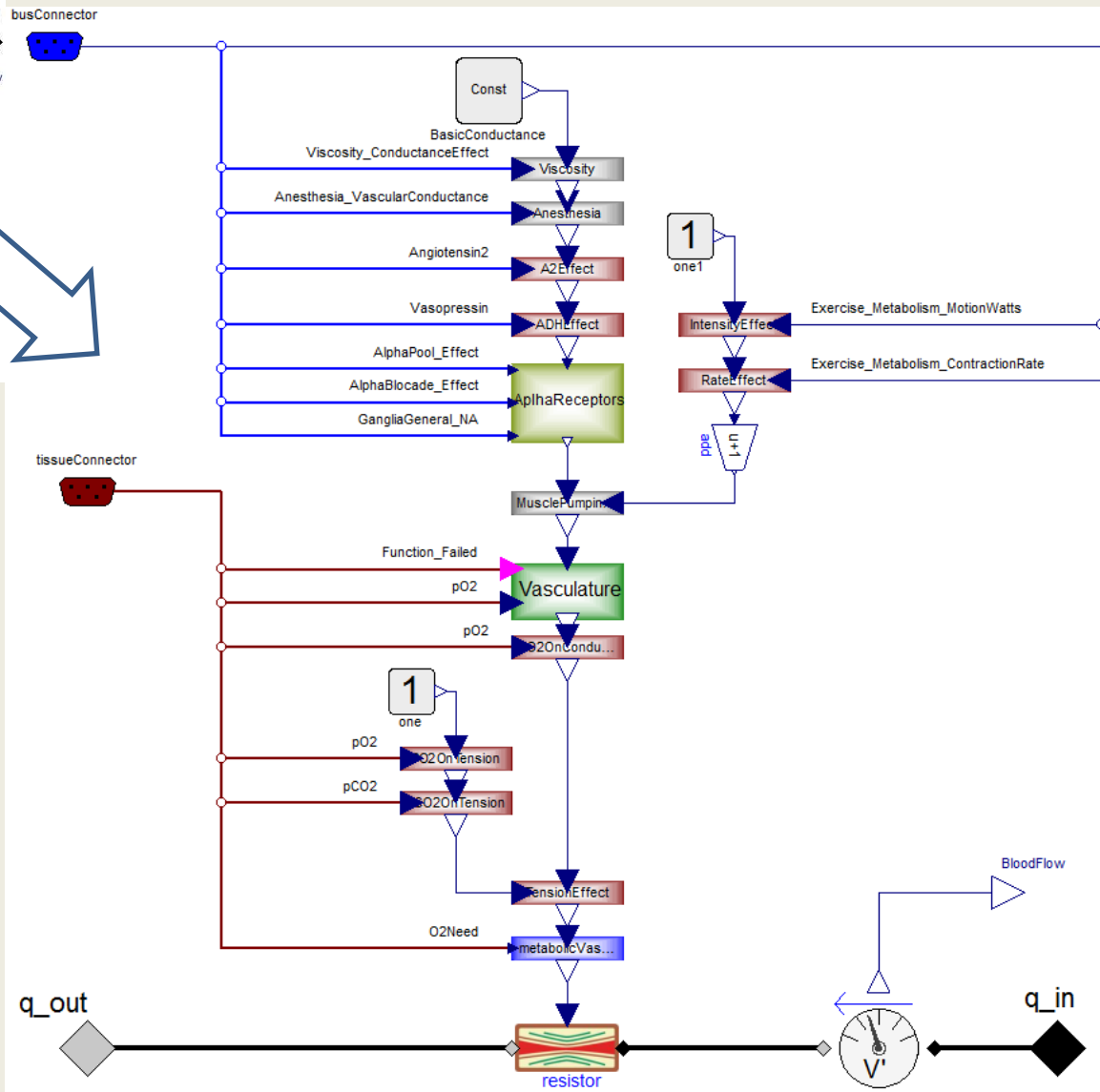

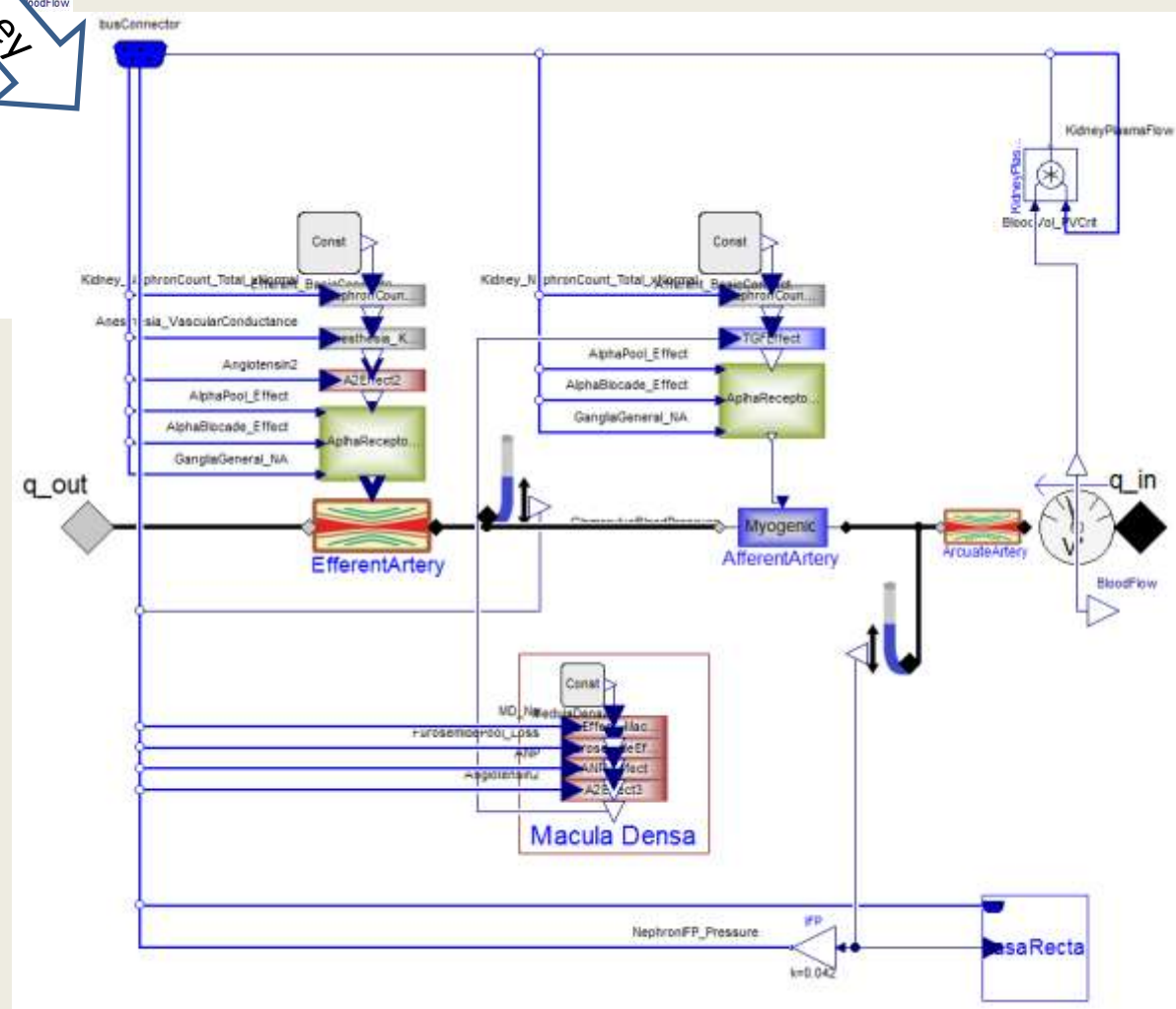
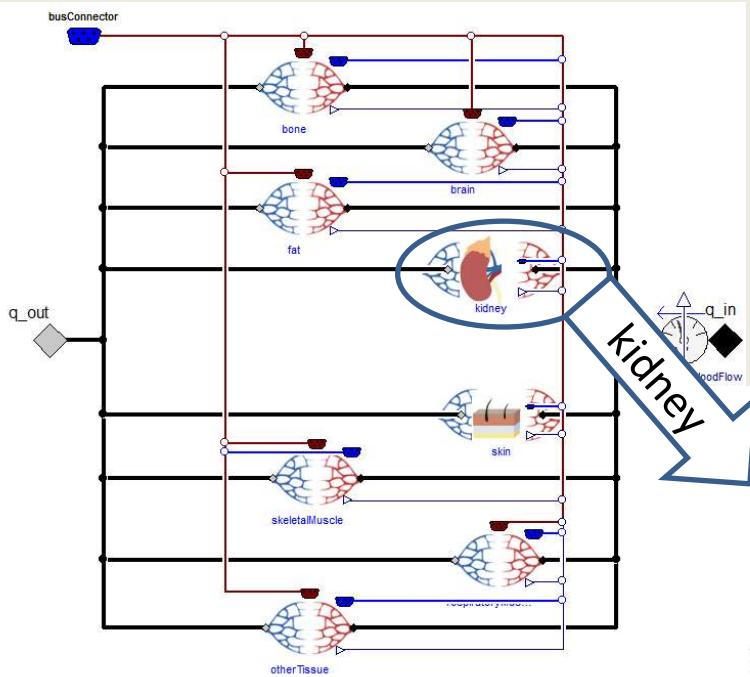

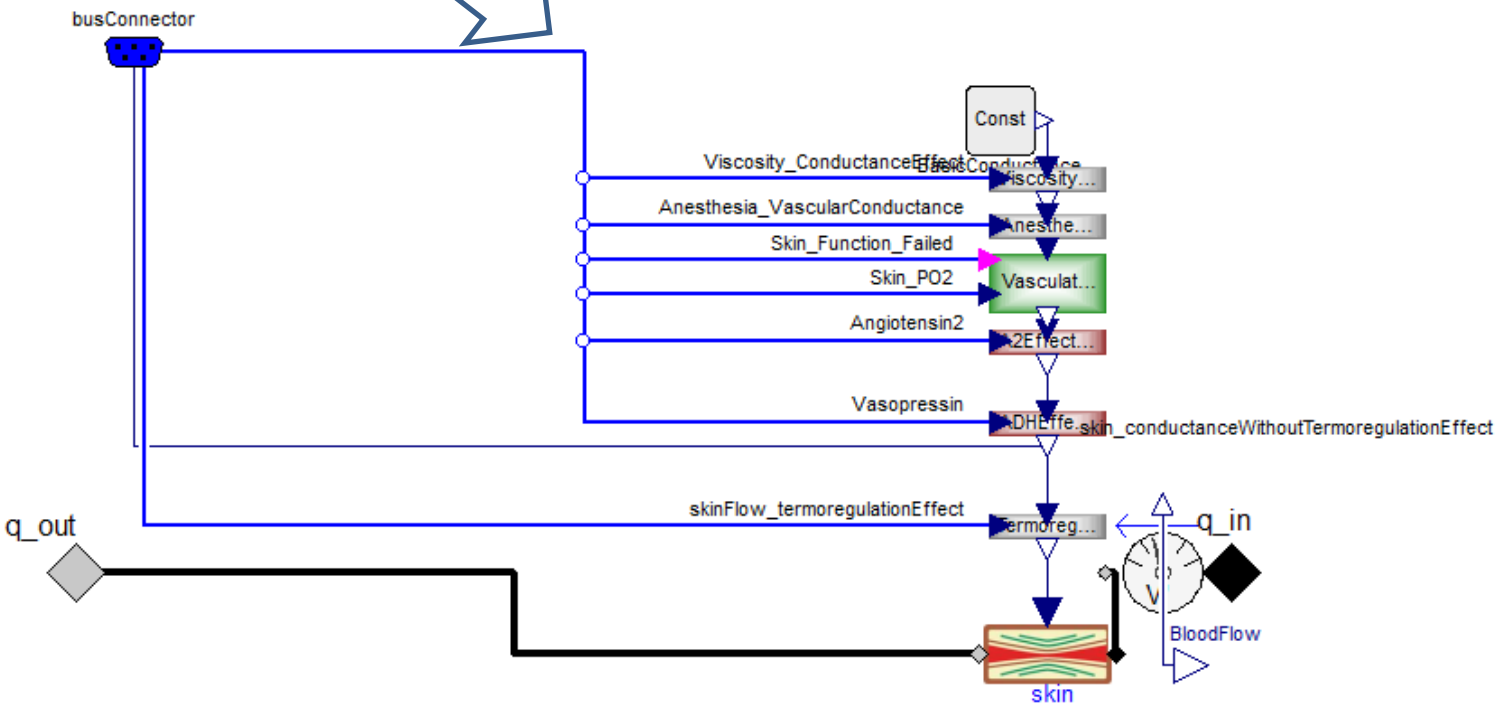
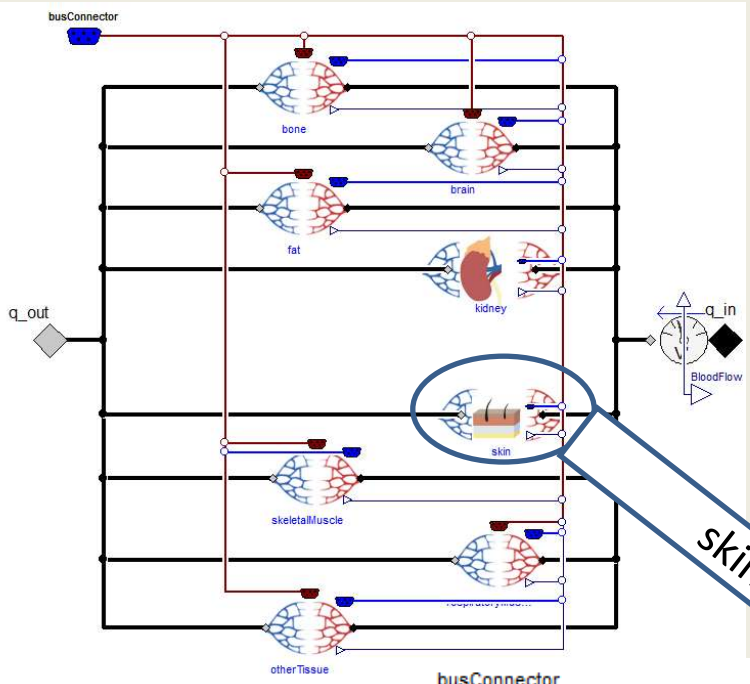

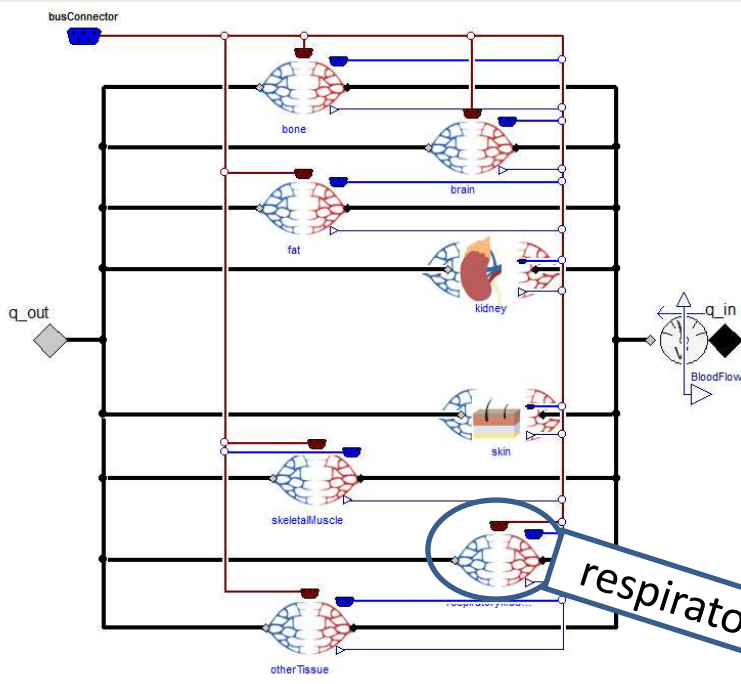

For GItract, bone, brain, fat, skeletalMuscle, respiratoryMuscle, otherTissue:
the instances of the same class with different parameters

respiratoryMuscle

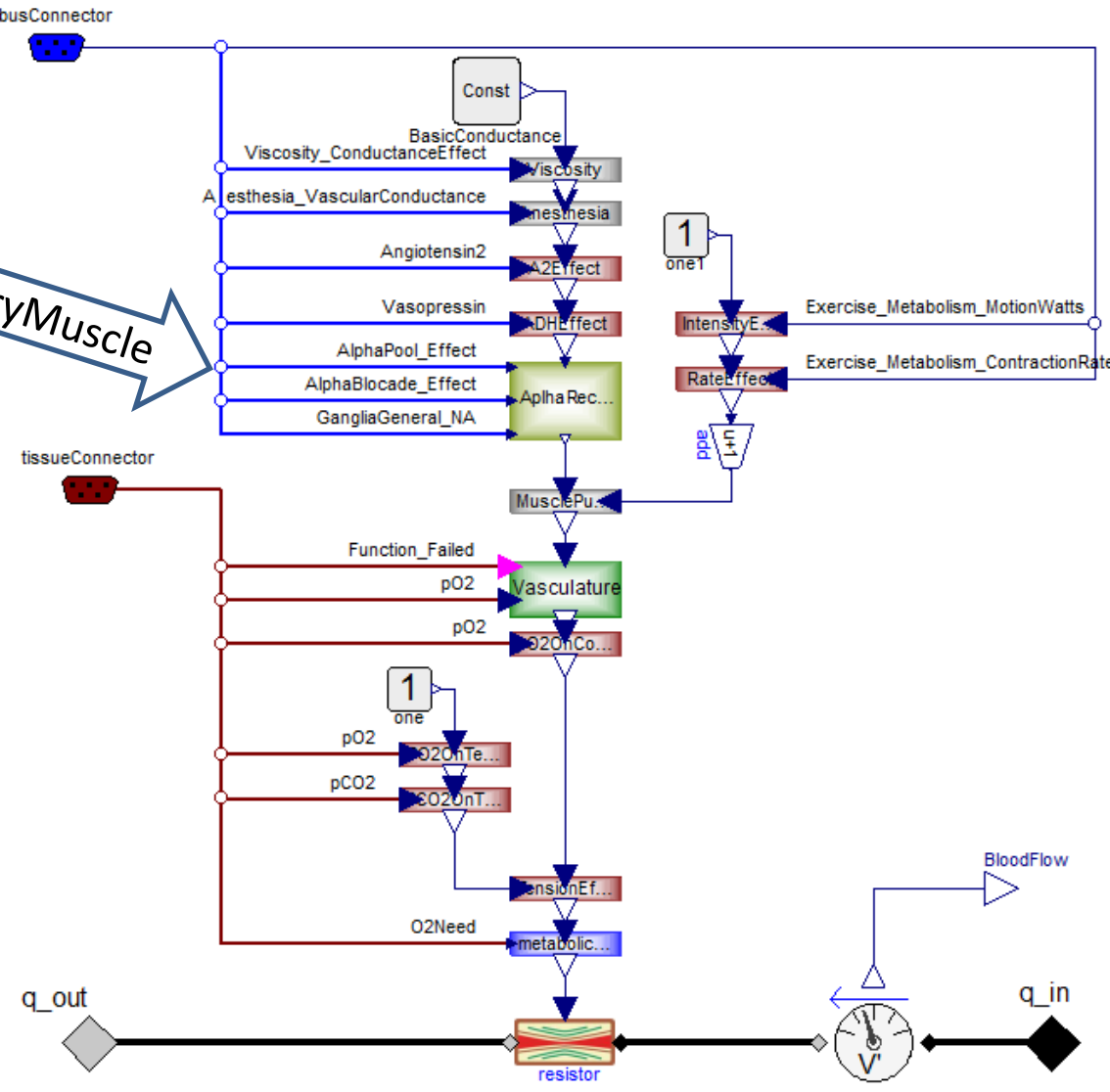

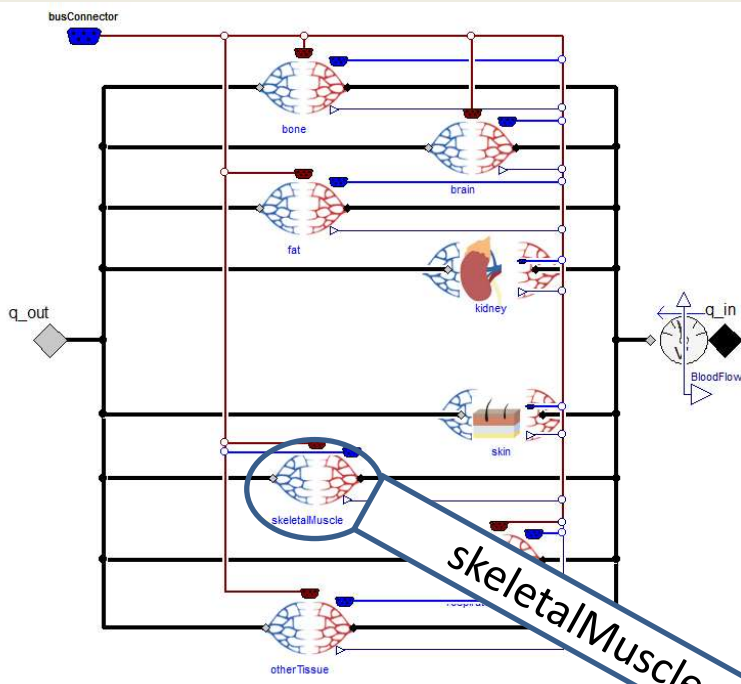

For GItract, bone, brain, fat, skeletalMuscle, respiratoryMuscle, otherTissue:
the instances of the same class with different parameters

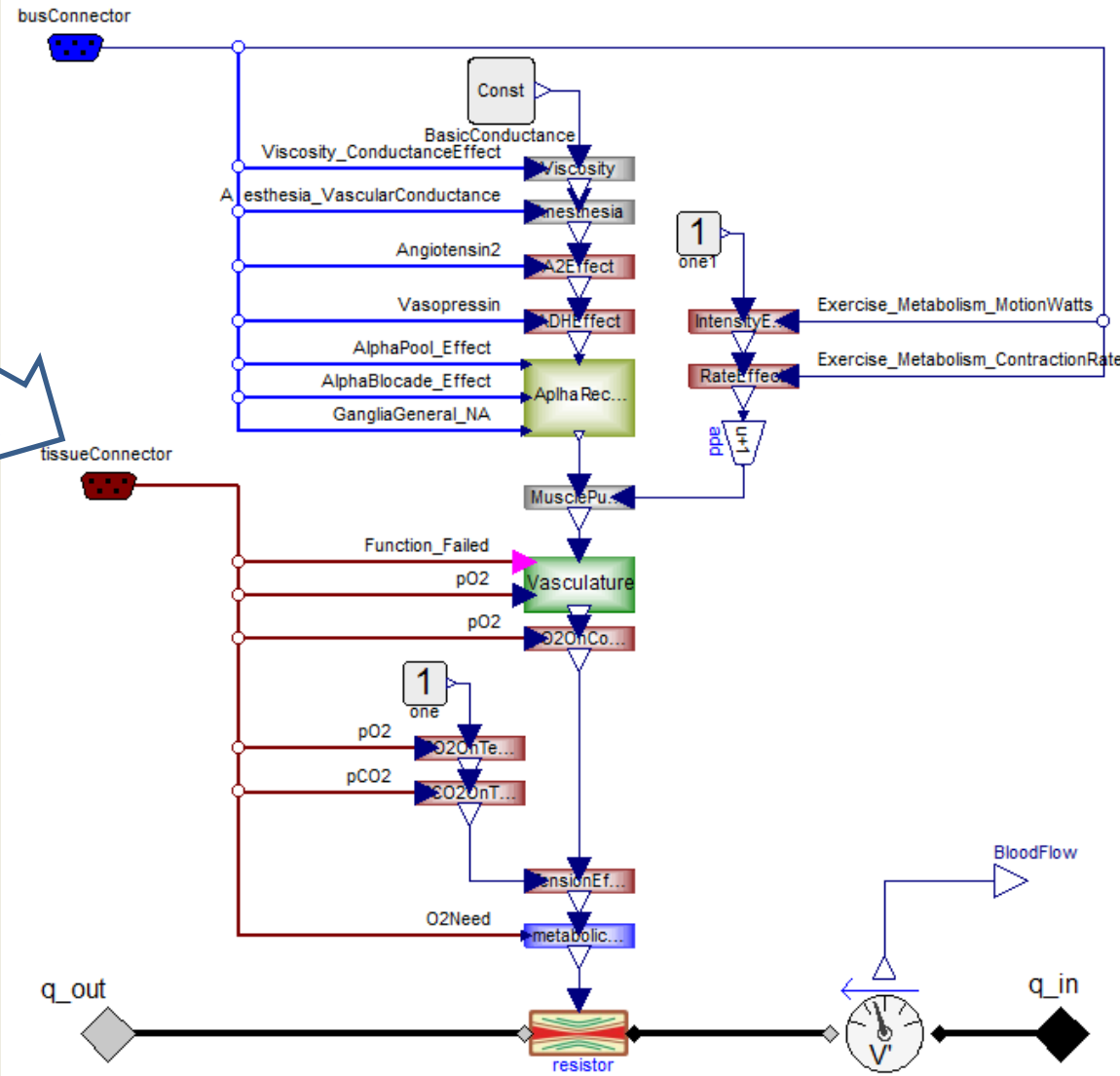

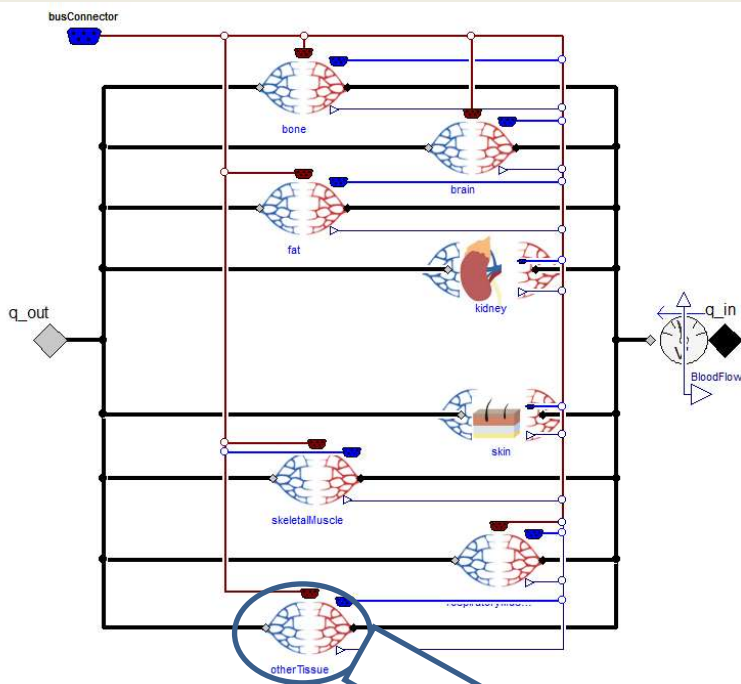

For GItract, bone, brain, fat, skeletalMuscle, respiratoryMuscle, otherTissue:
the instances of the same class with different parameters

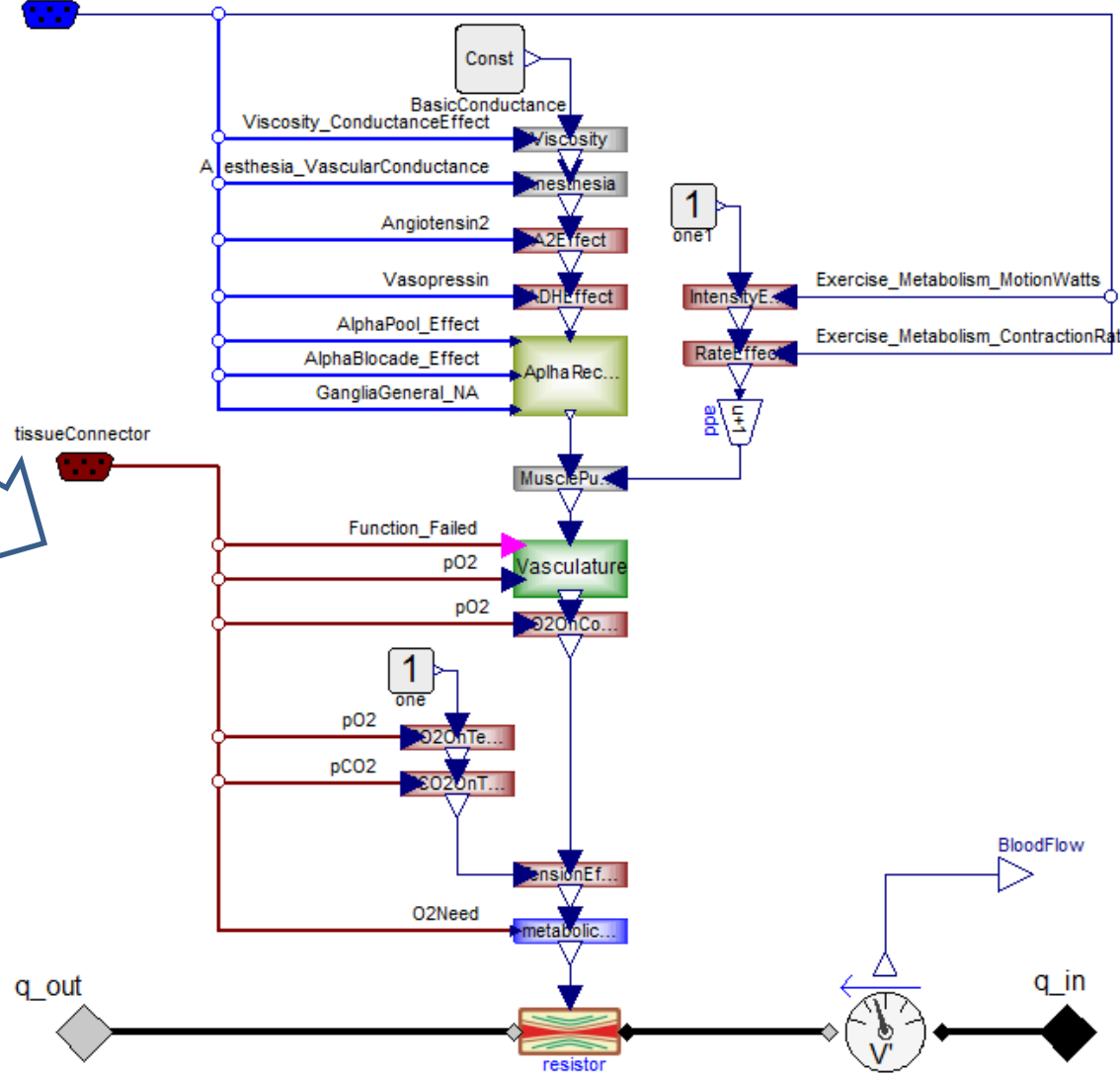
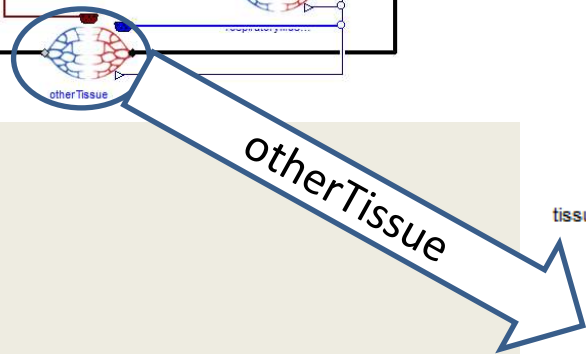

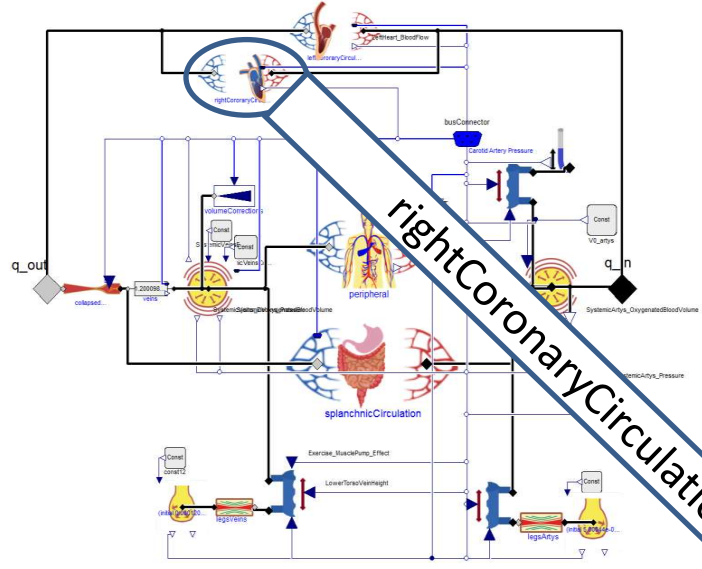

rightCoronaryCirculation

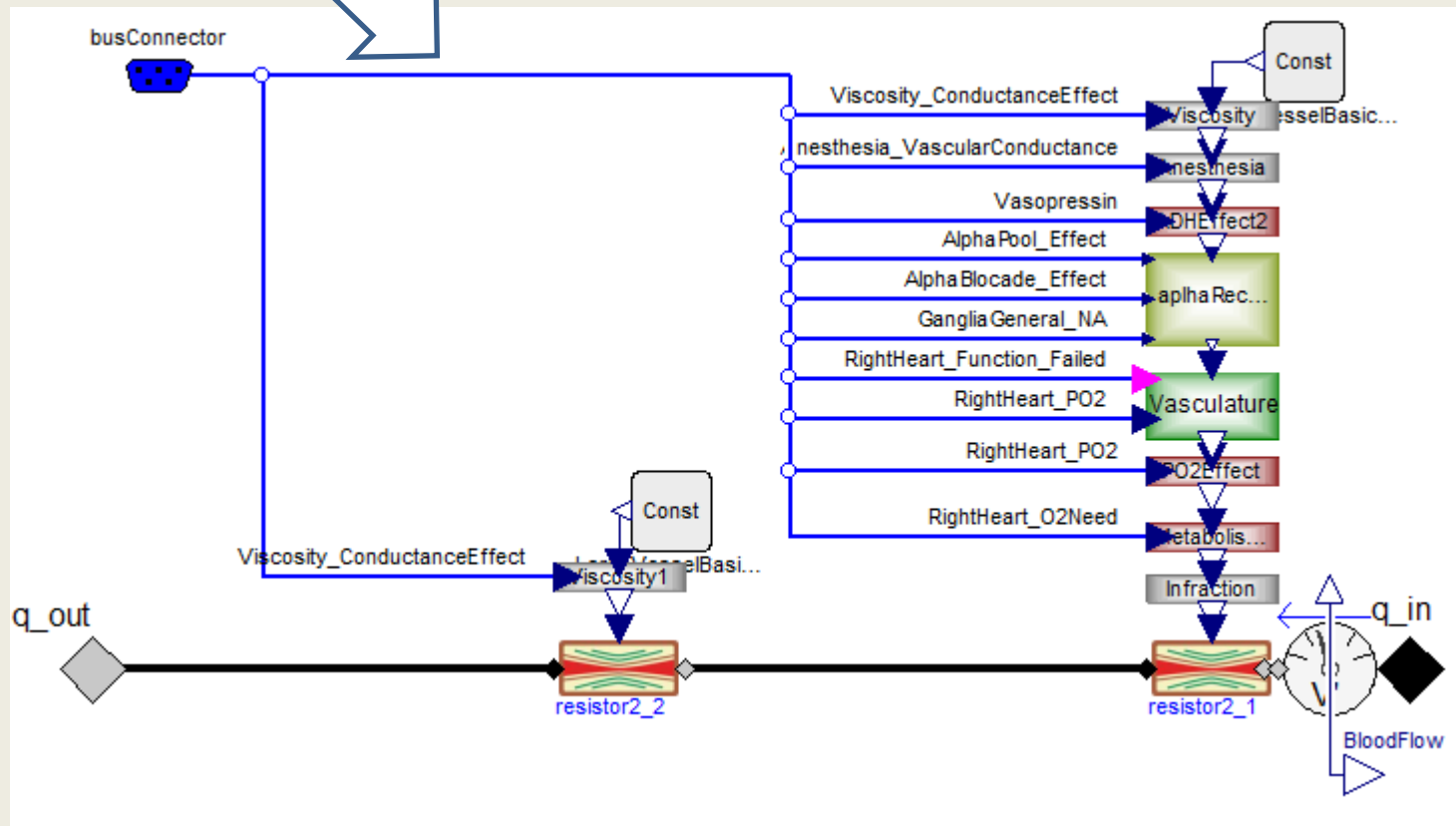

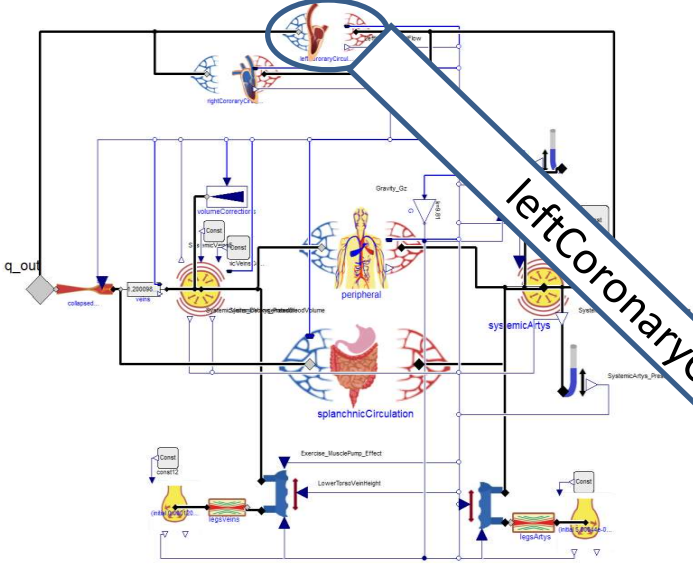

leftCoronaryCirculation

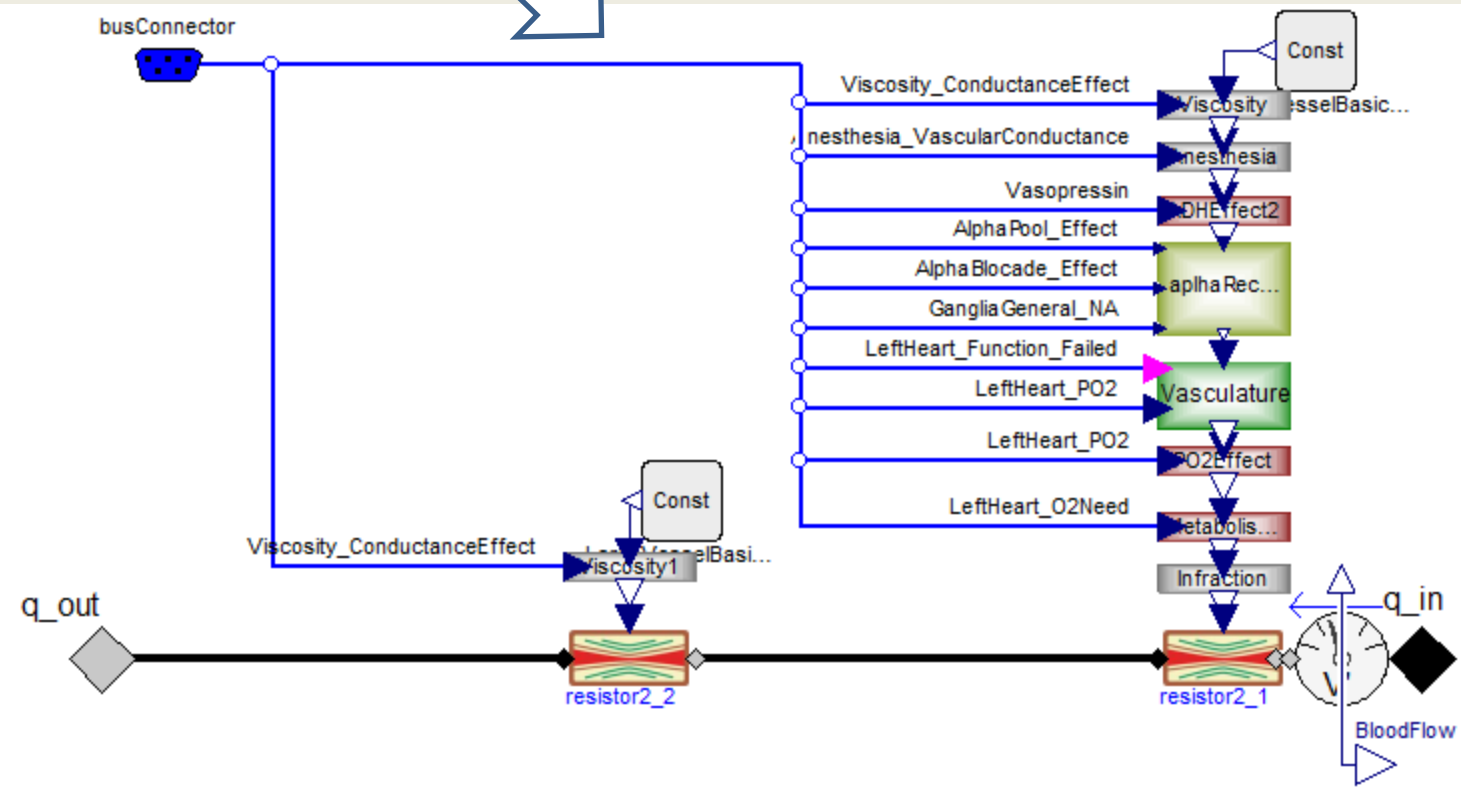

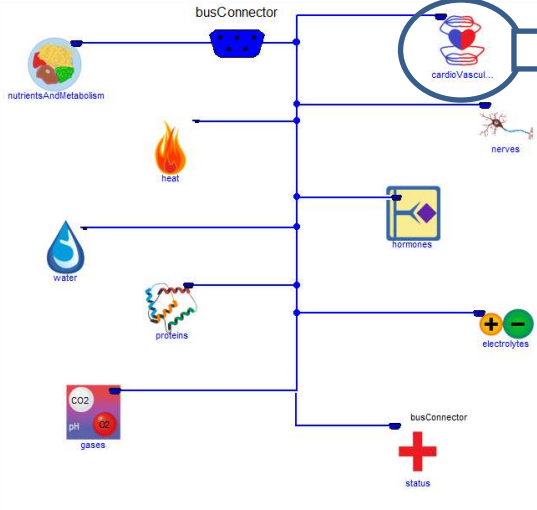

cardioVascularSystem

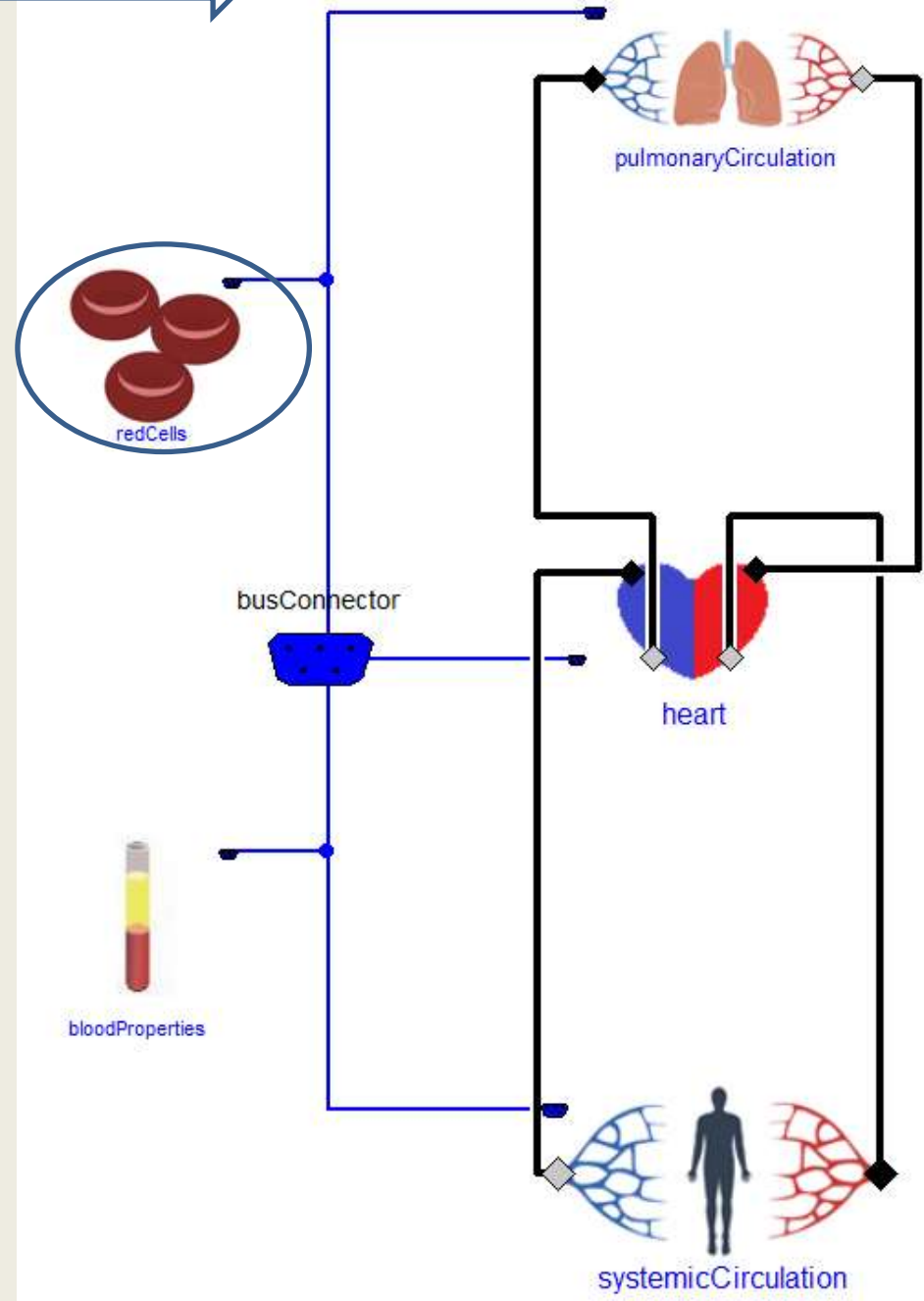

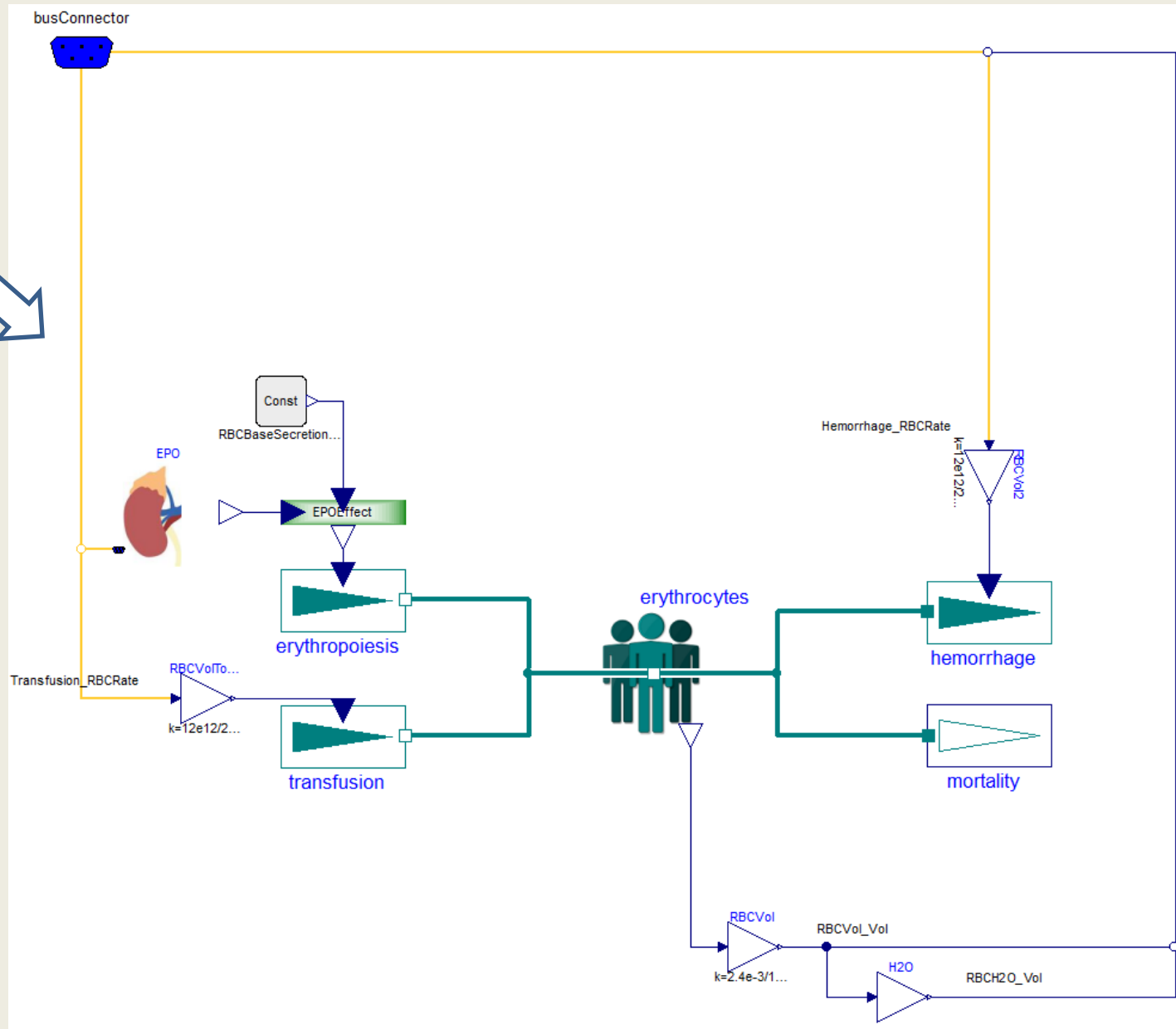
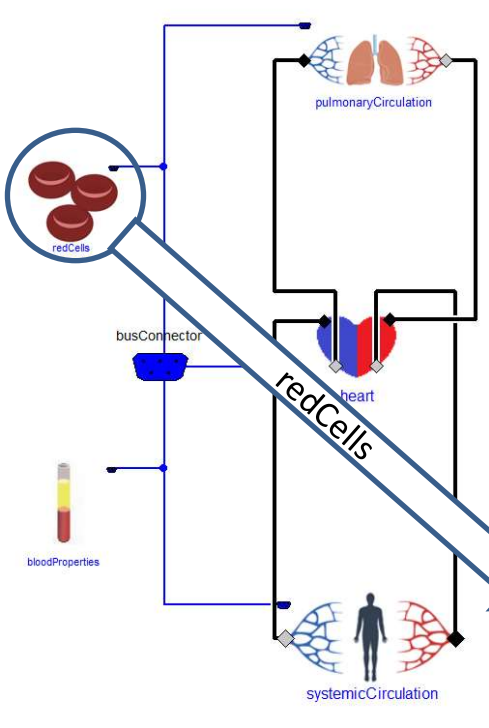

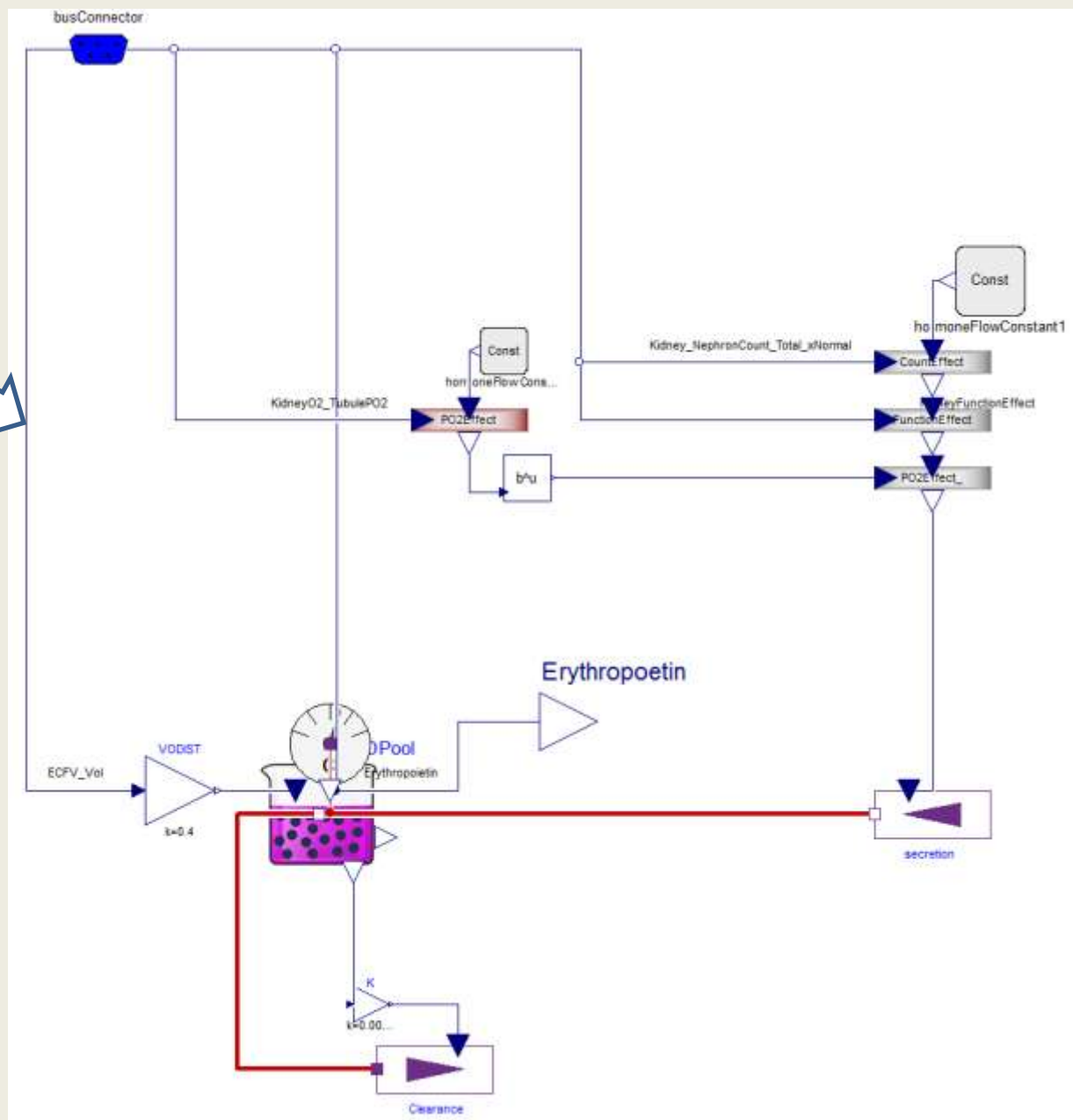
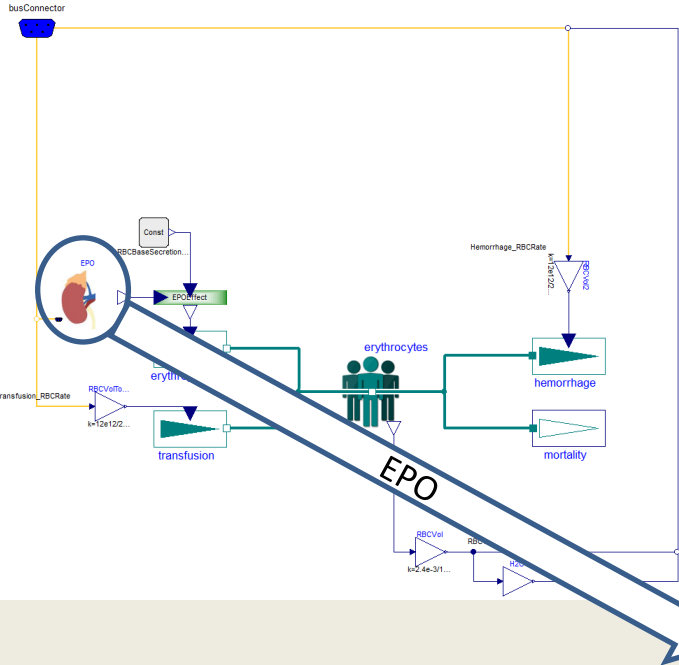

EPO

Erythropoietin

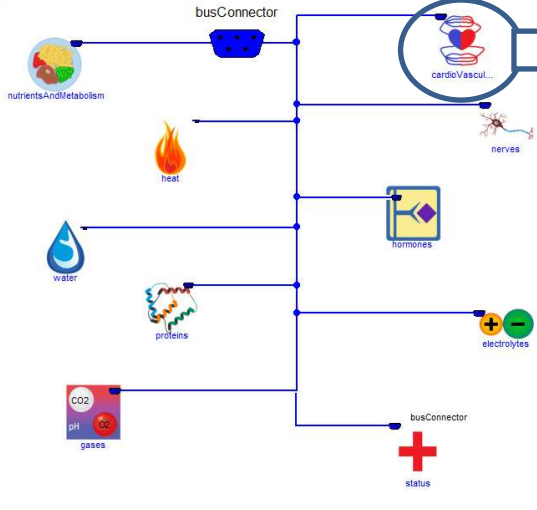

cardioVasculSystem

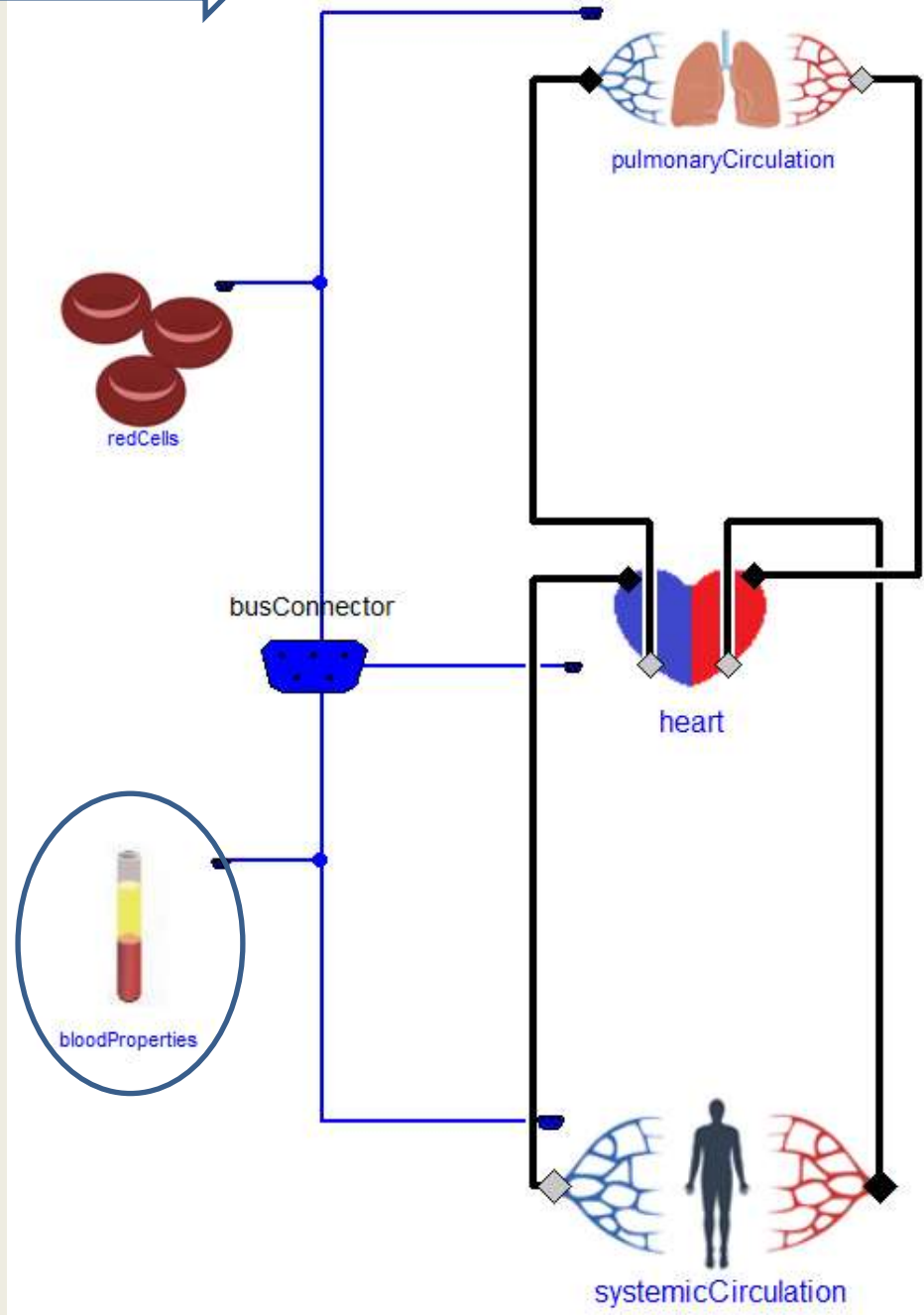

busConnector

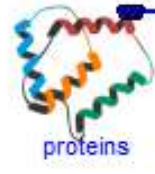
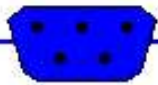
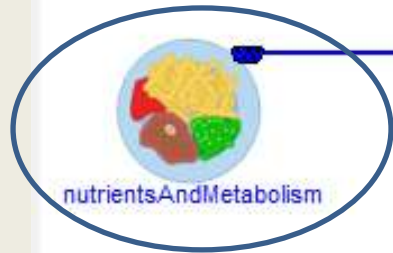

busConnector



status

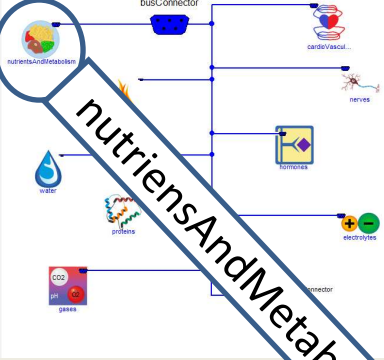

nutriensAndMetabolism

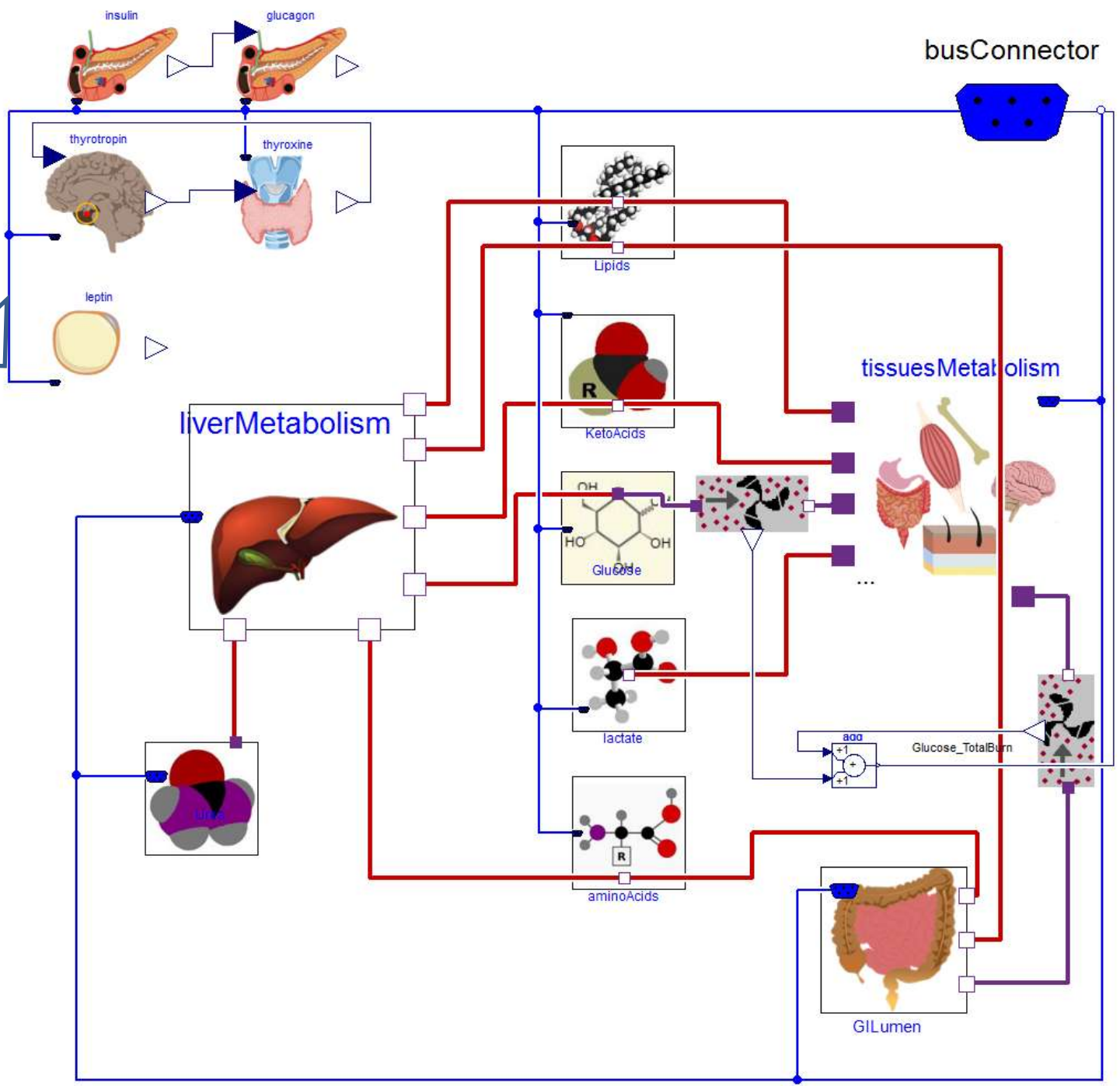

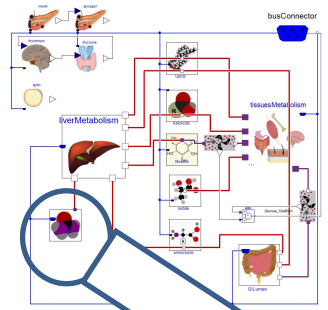

urea

busConnector

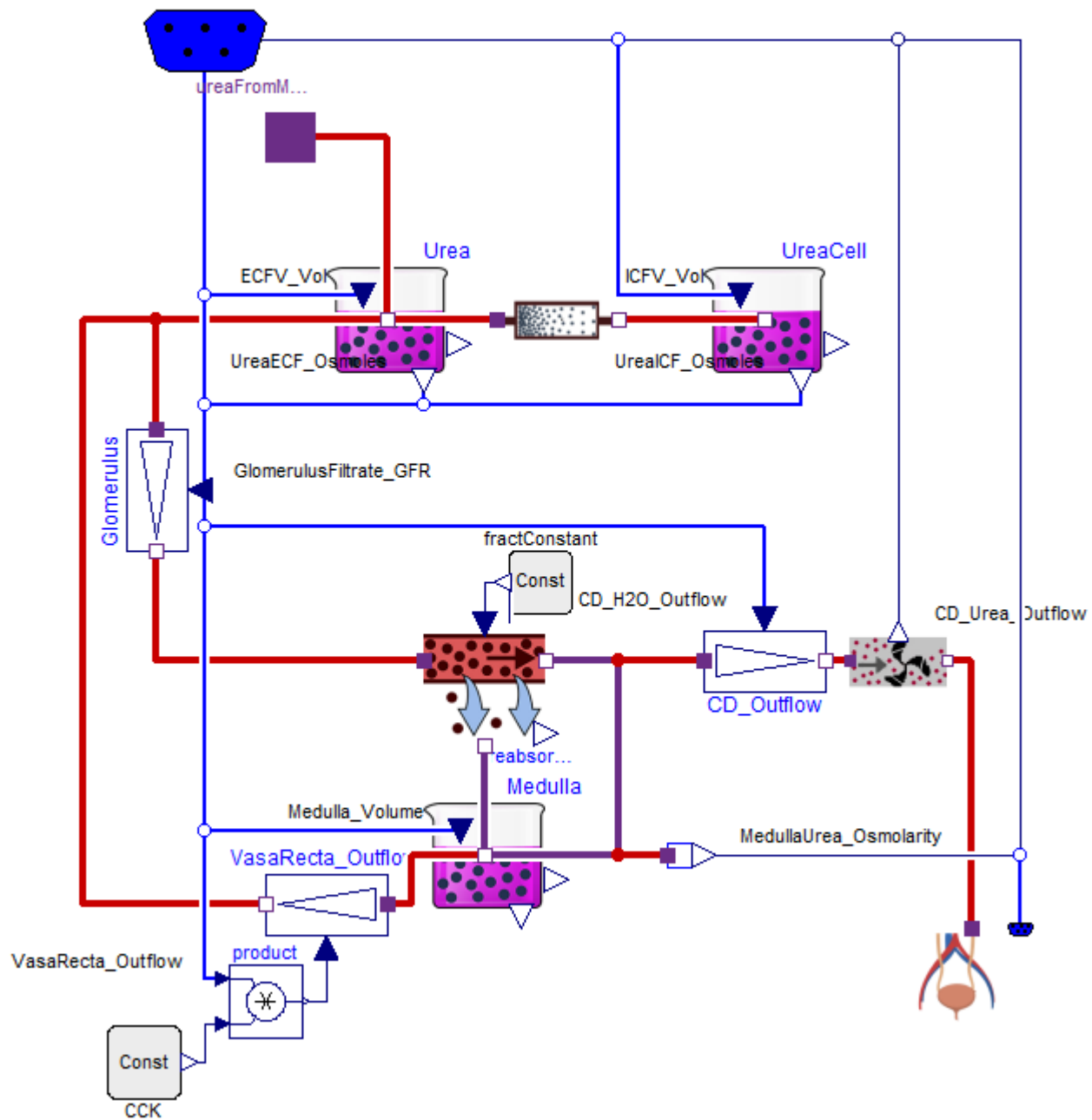

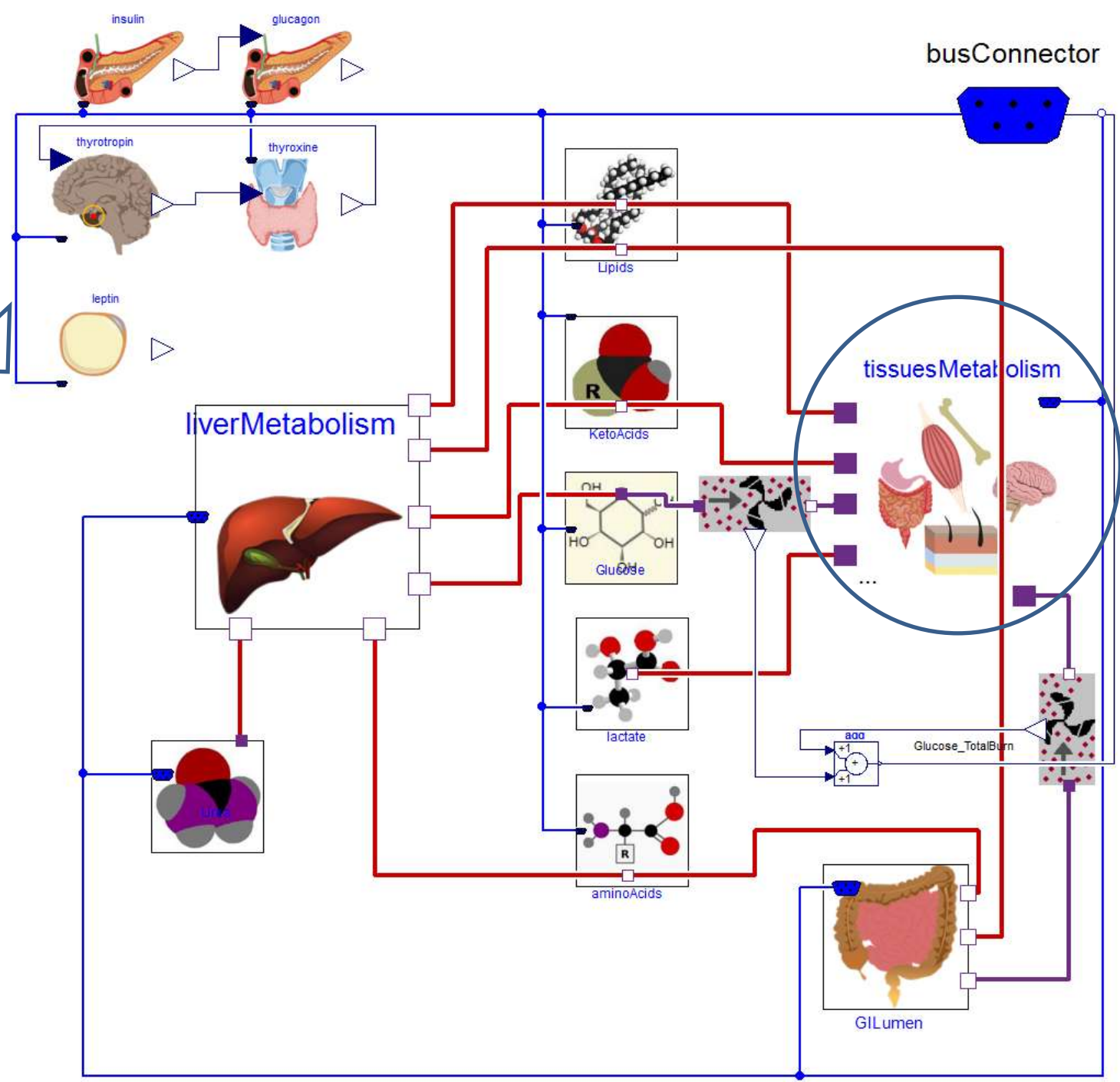
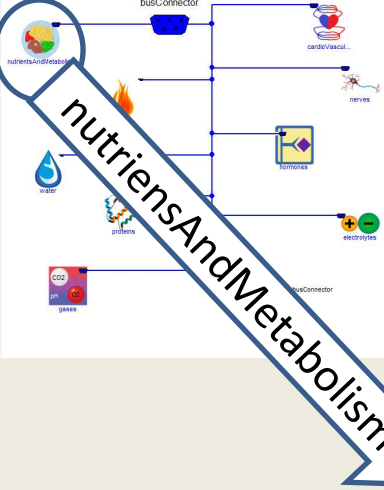

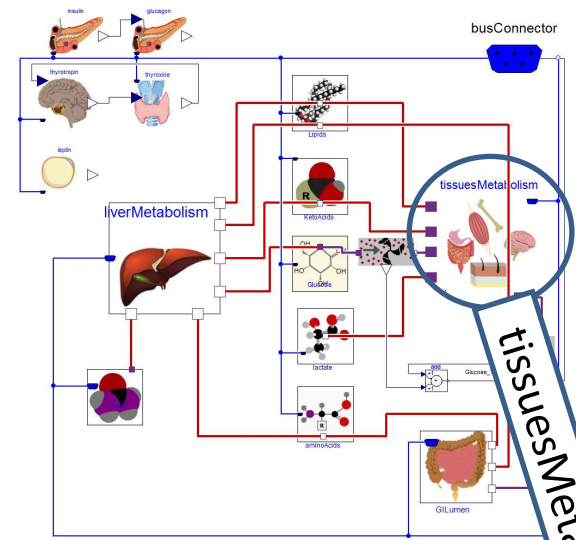

tissuesMetabolism

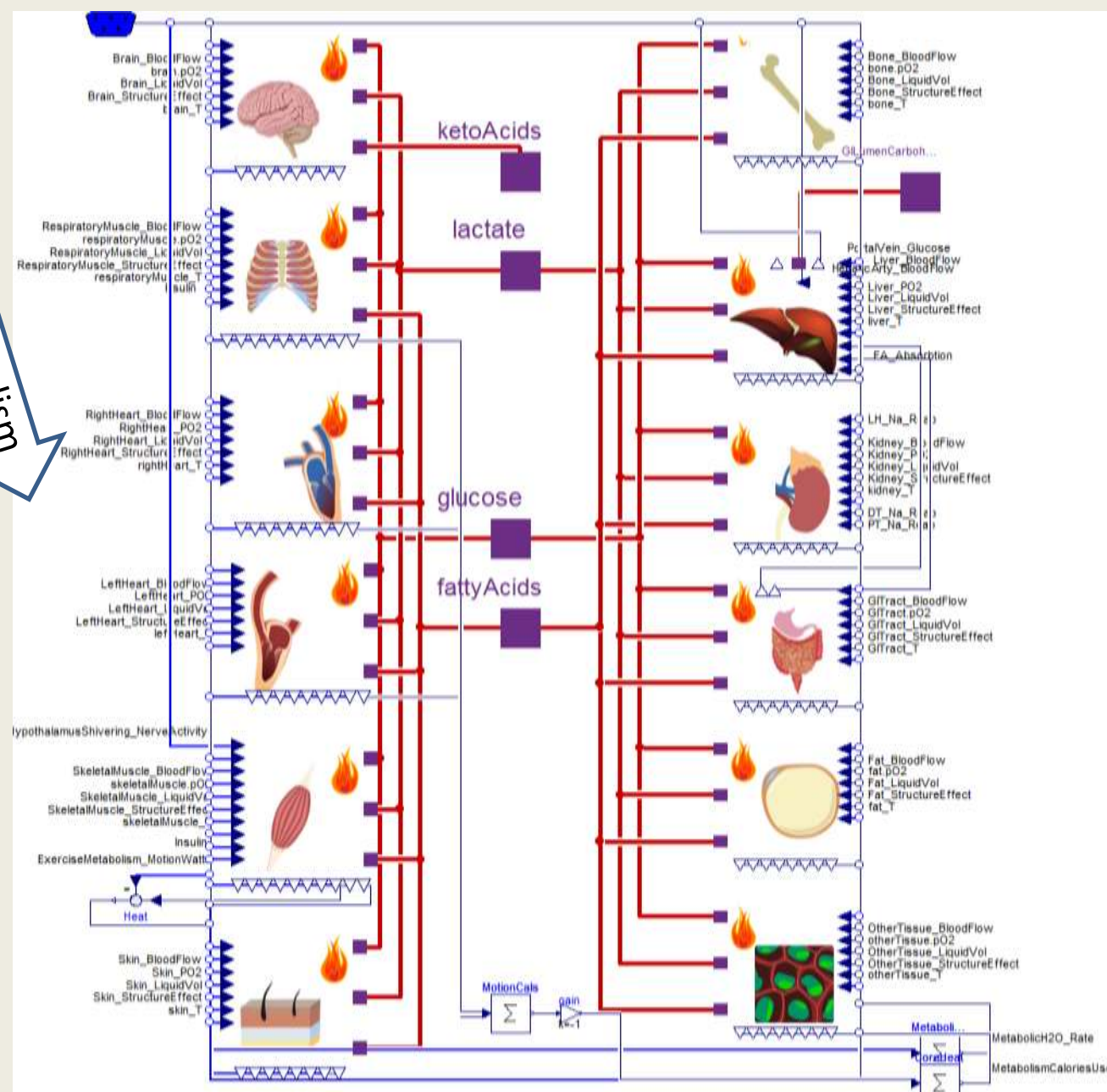

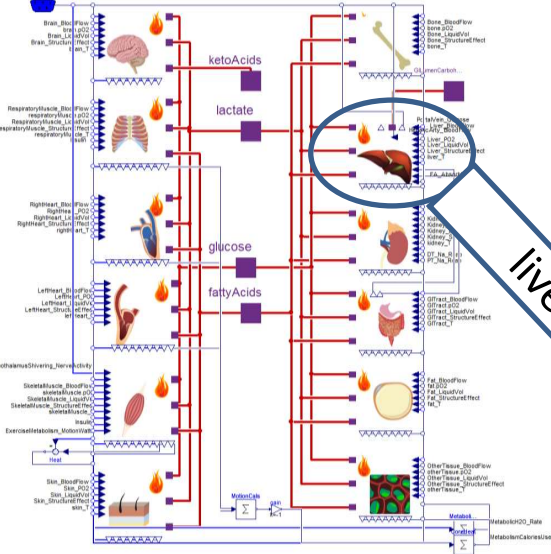

For brain, respiratoryMuscle, rightHeart, leftHeart, skeletalMuscle, skin, bone, liver, kidney, GItract, fat and otherTissue: the instances of the same class with different parameters

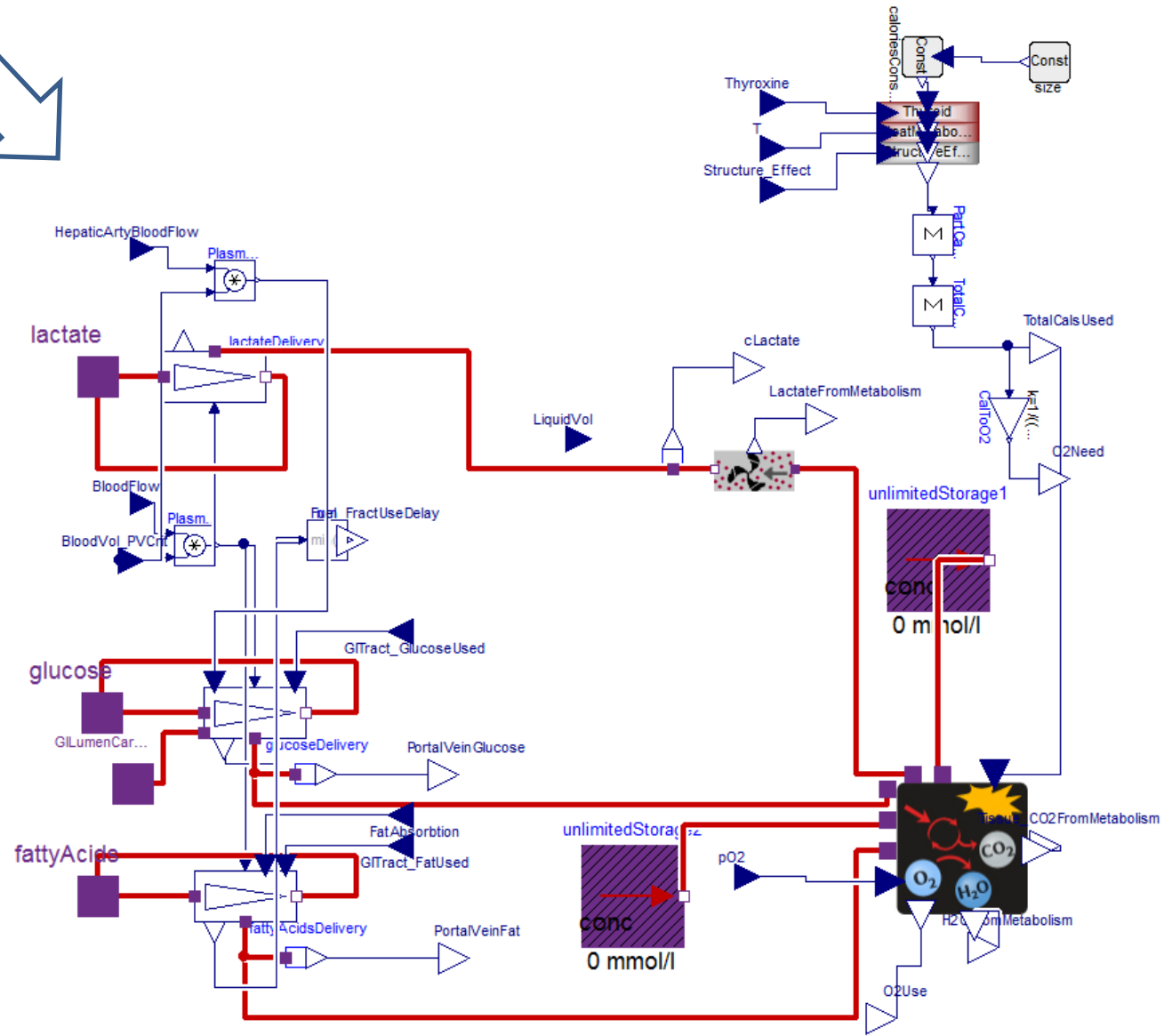

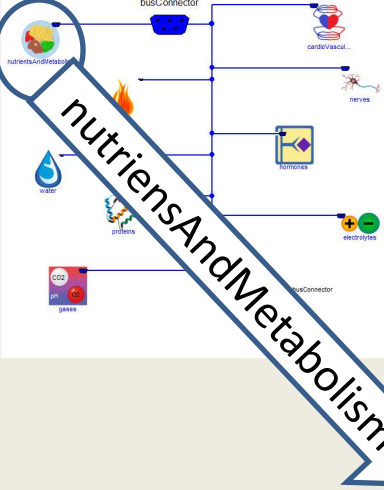

nutrientsAndMetabolism

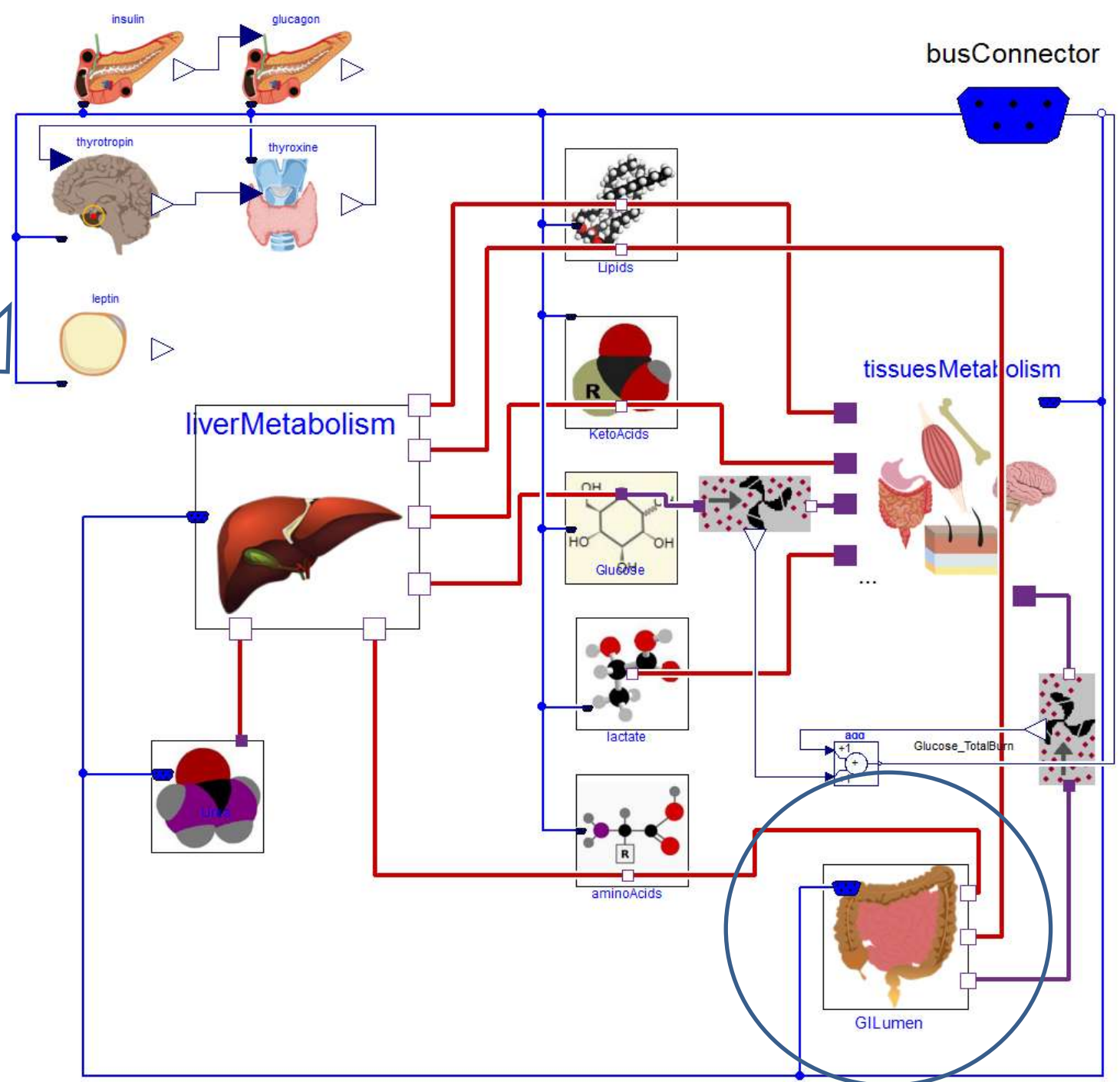

busConnector

LiverMetabolism

tissuesMetabolism

GI Lumen

Glucose_TotaBurn

Lipids

KetoAcids

Glucose

lactate

aminoAcids

thyrotropin

thyroxine

leptin

insulin

glucagon

add

1

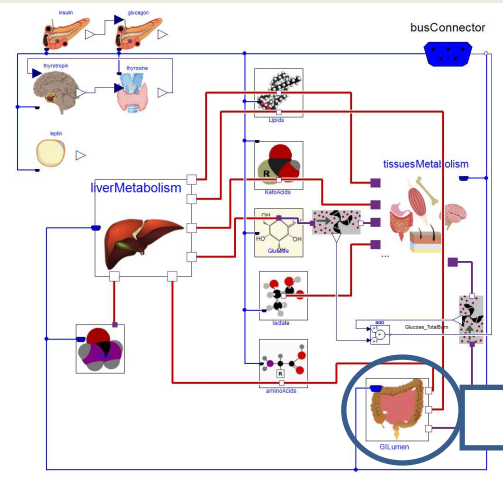

GILumen

busConnector

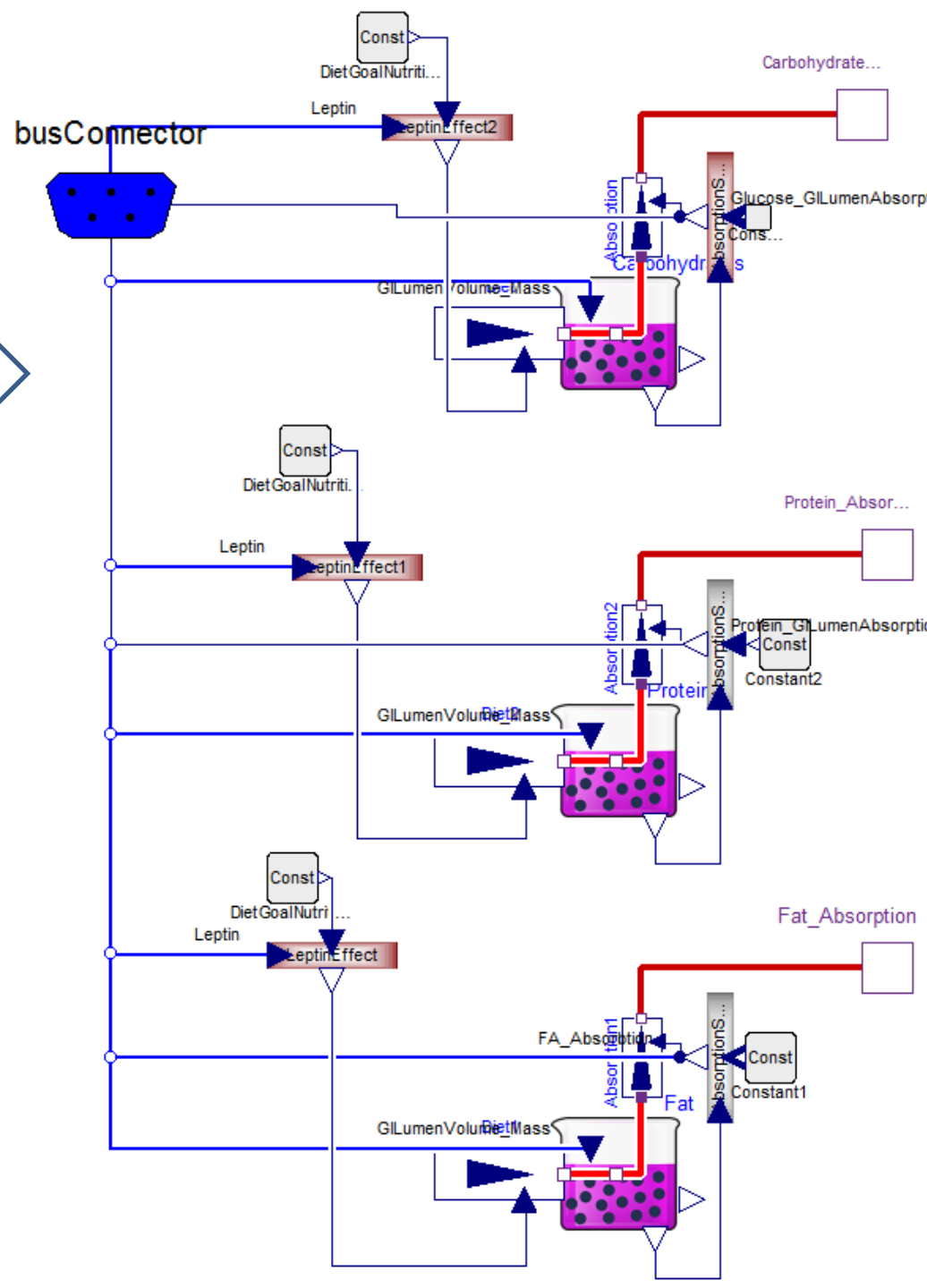

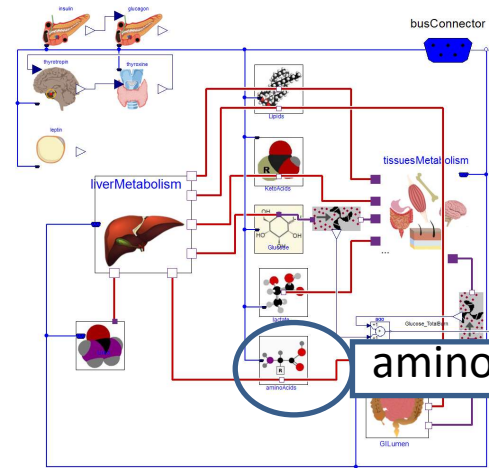

amino acids

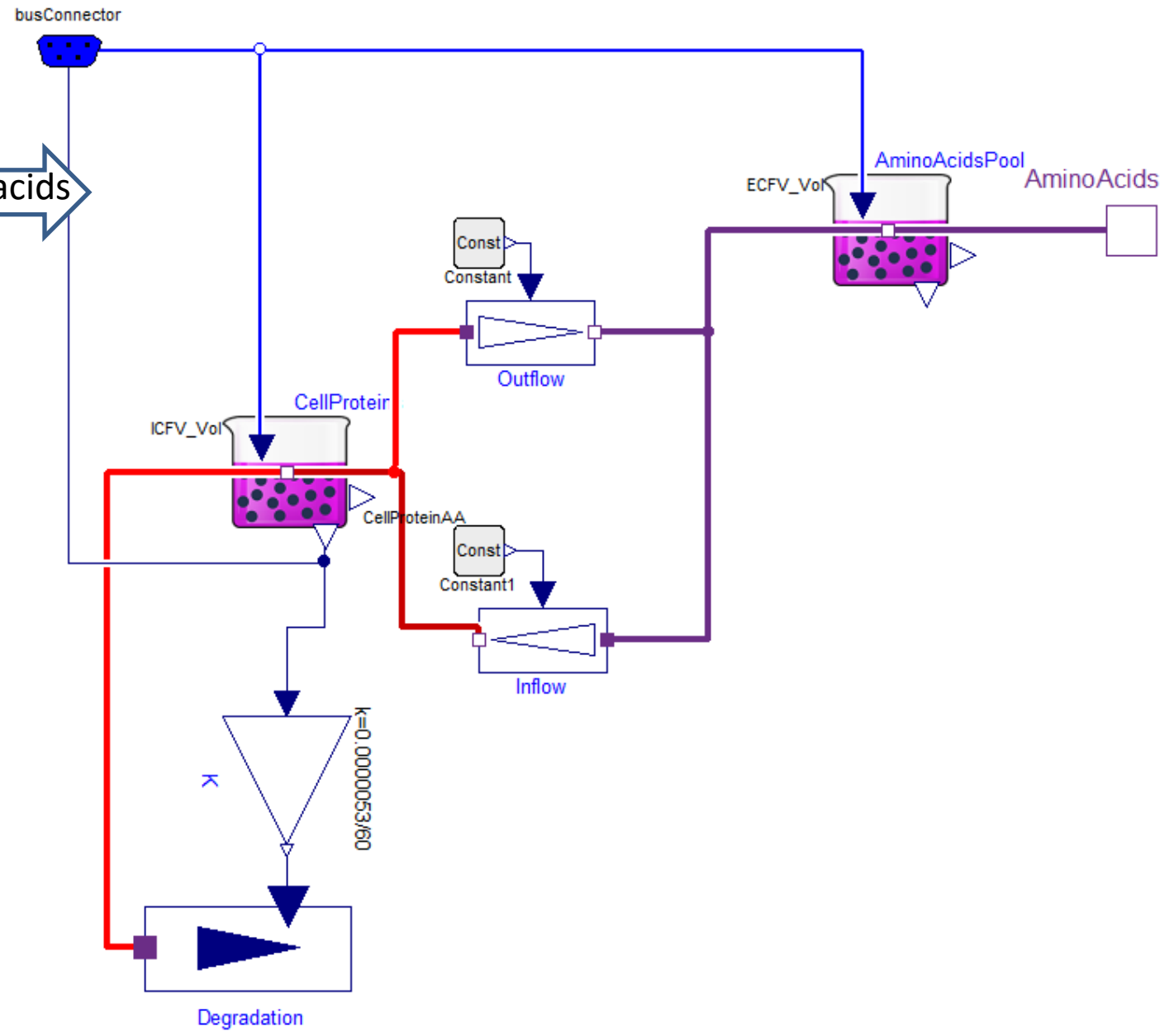

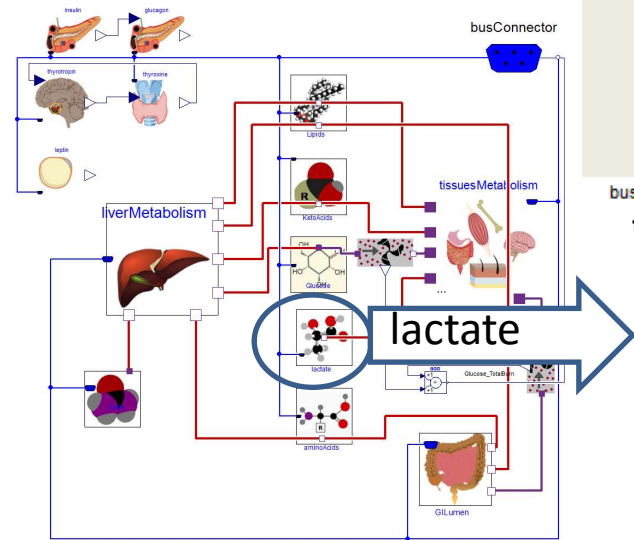

busConnector

Lactate

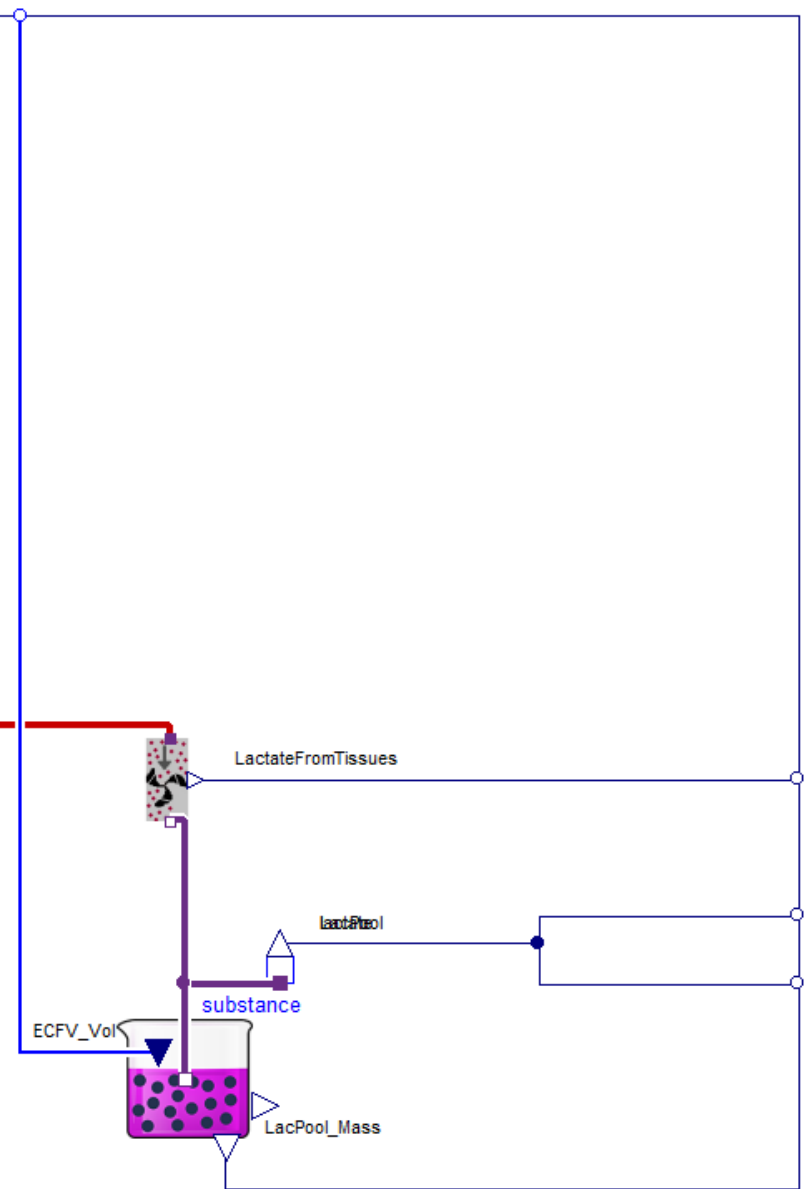

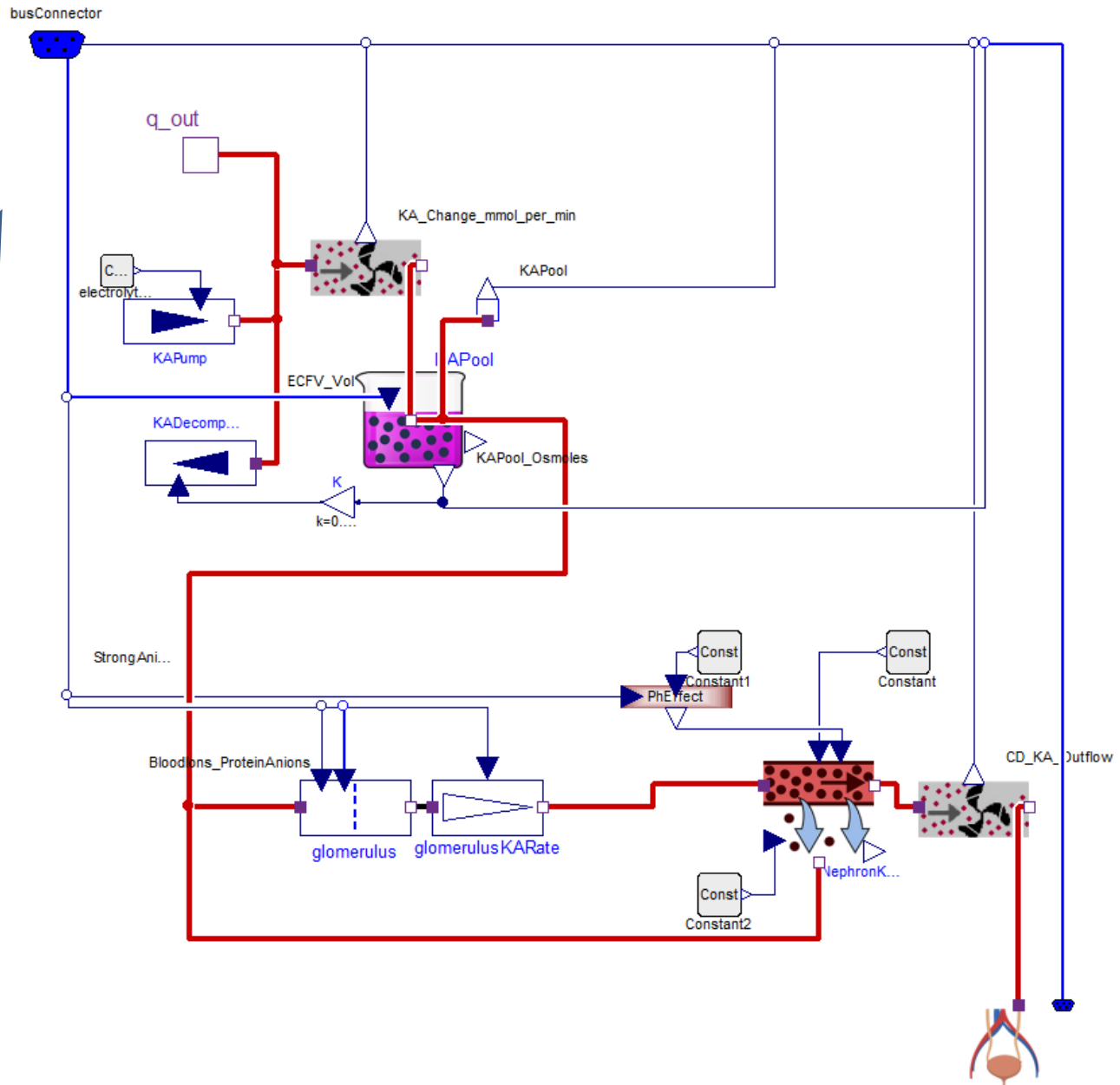
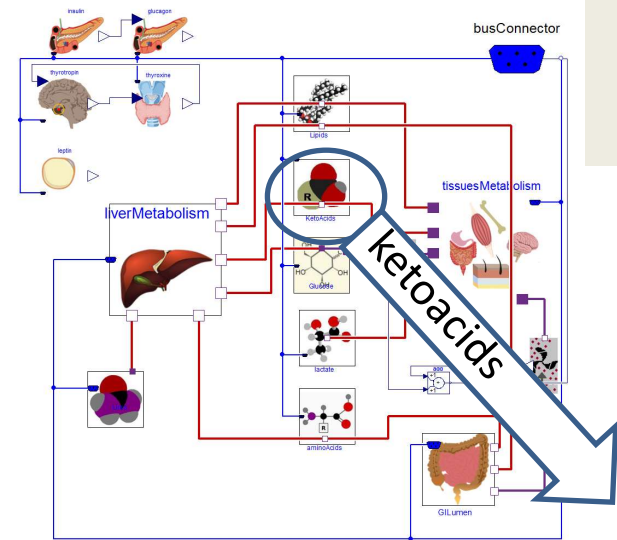

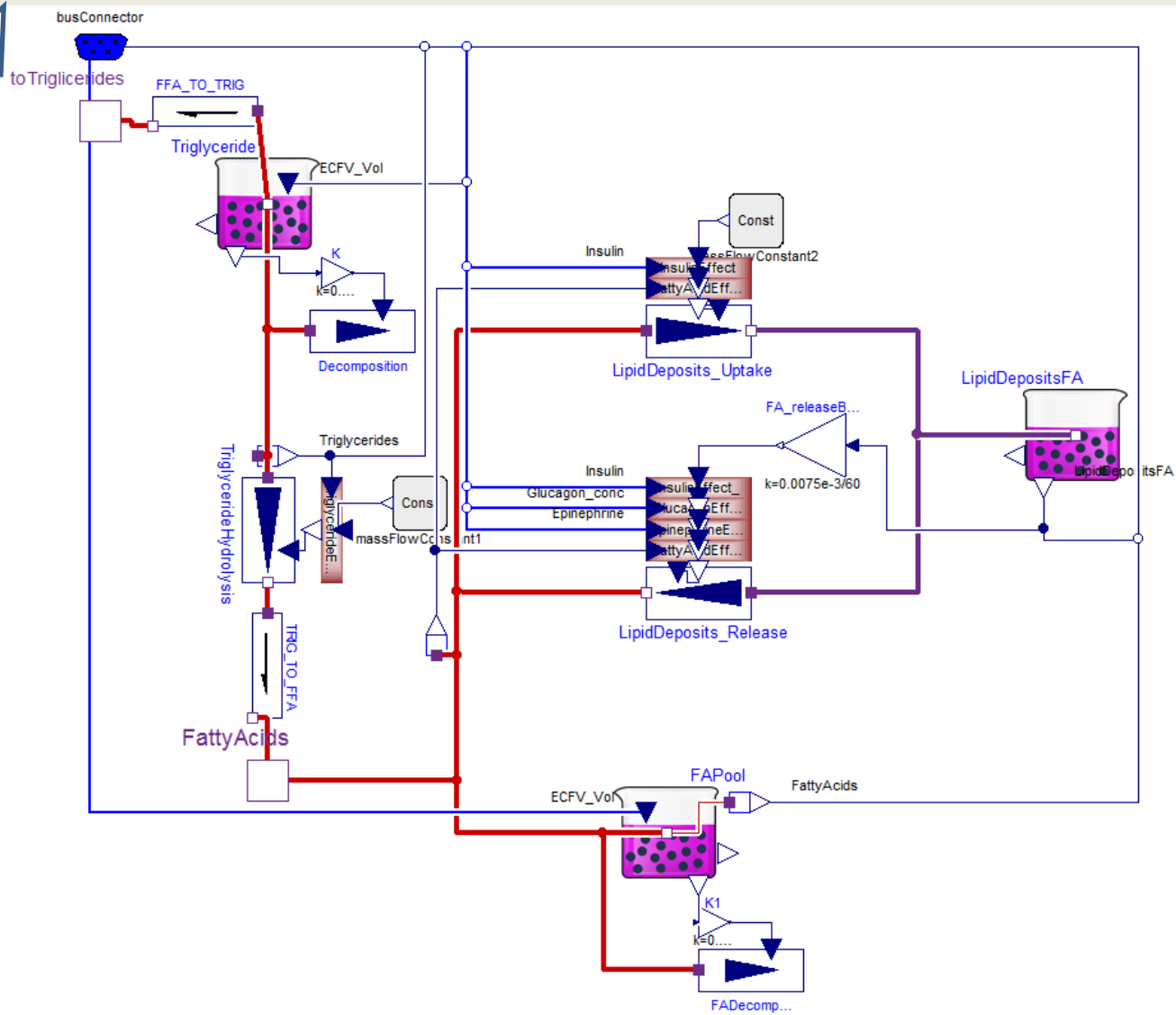
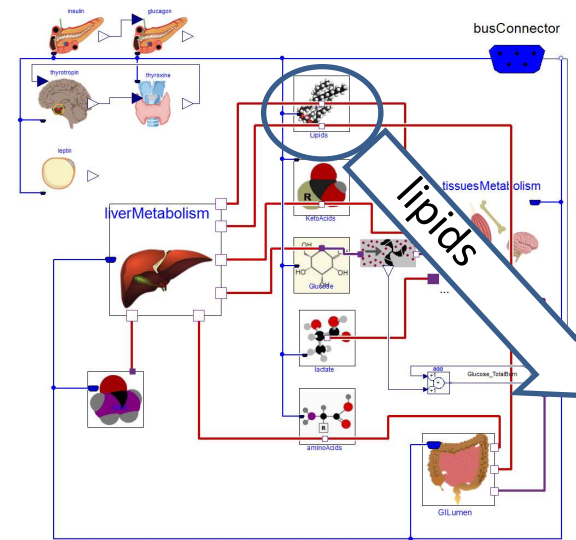

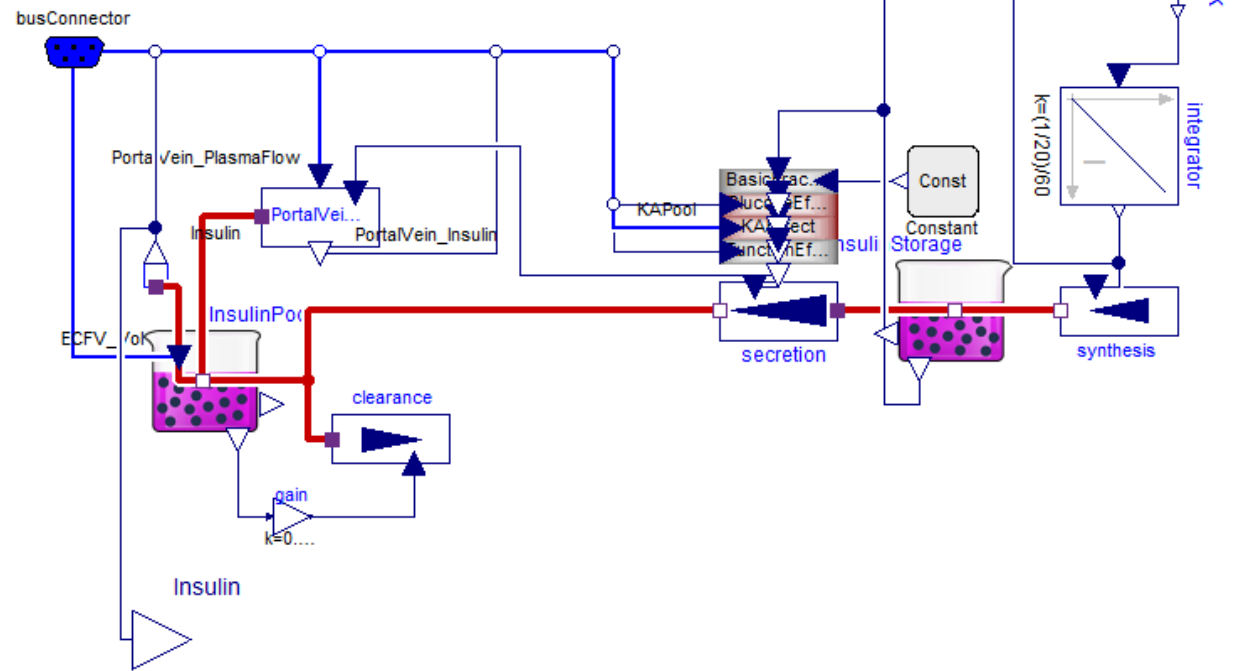
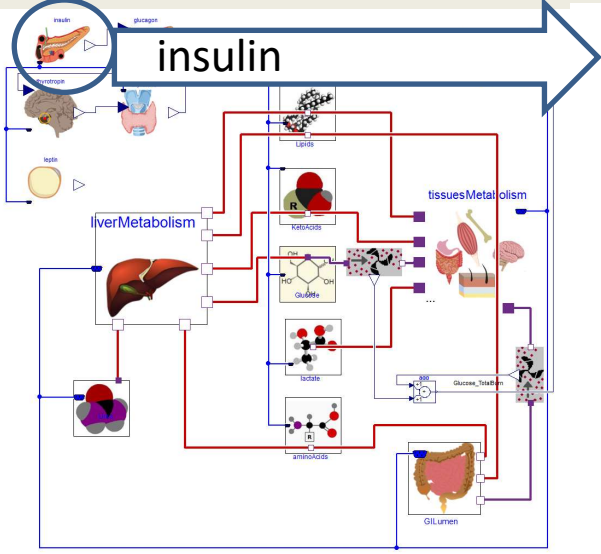

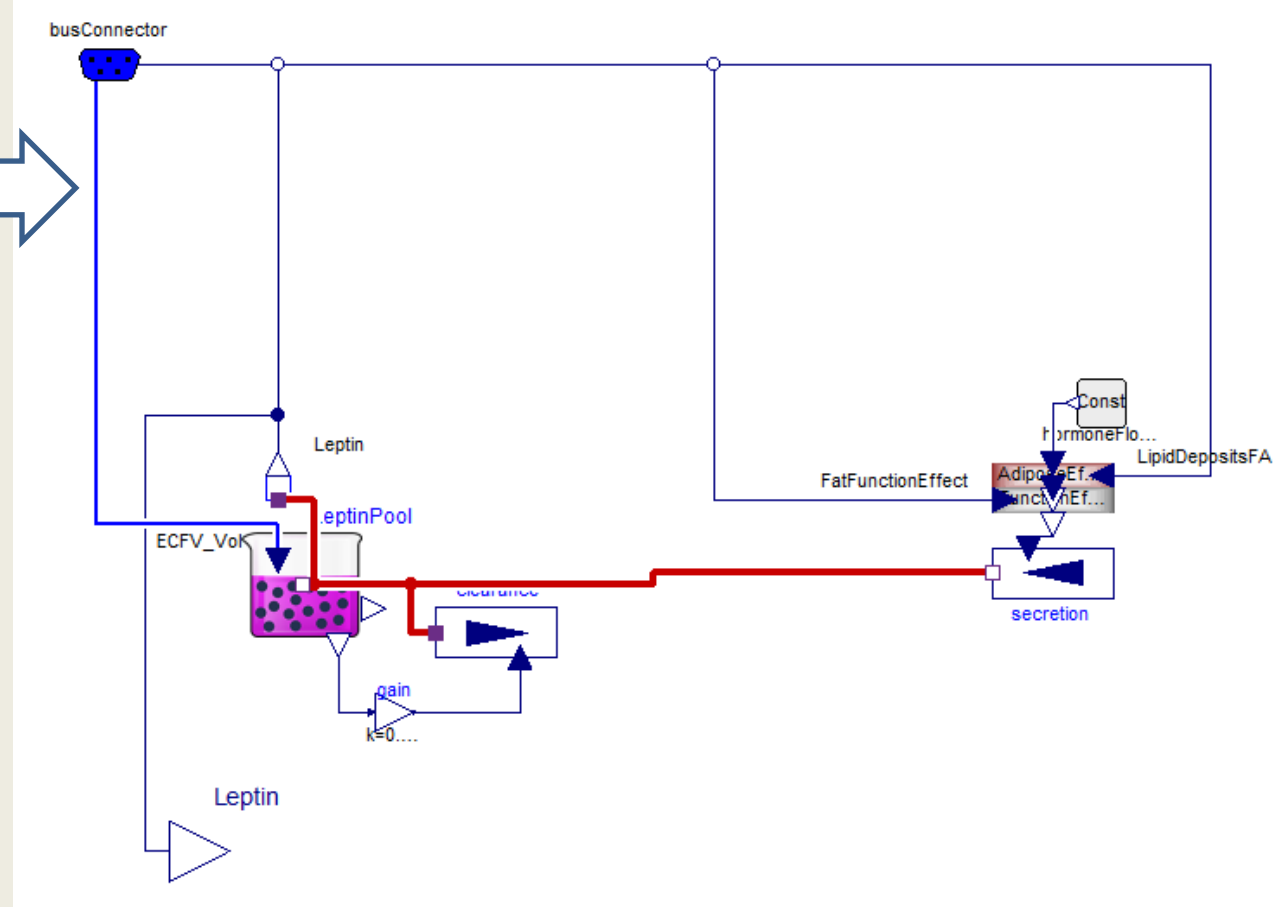
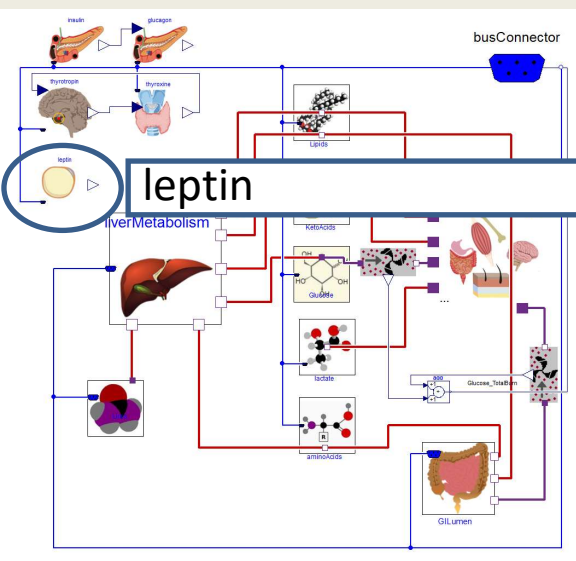

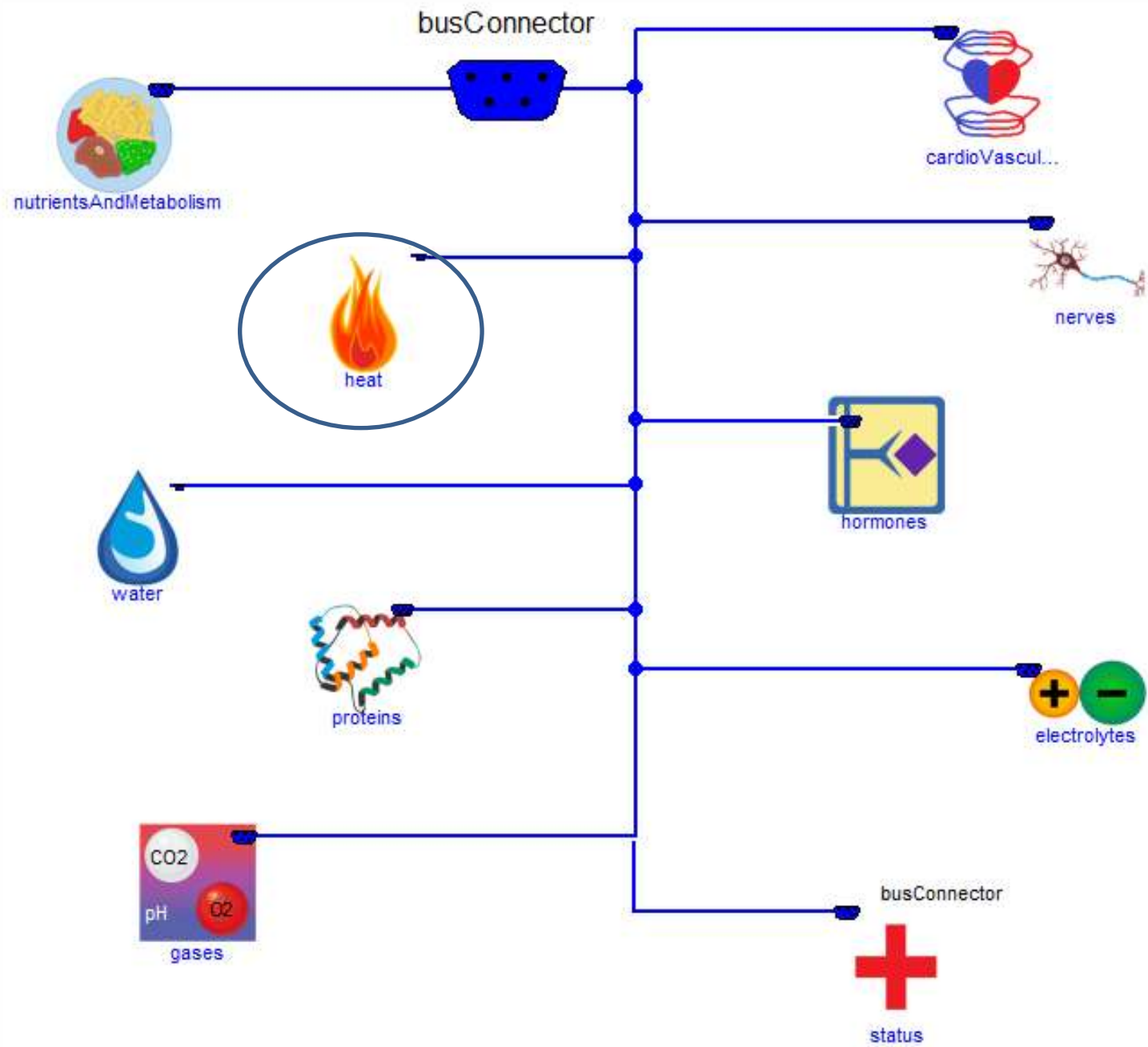

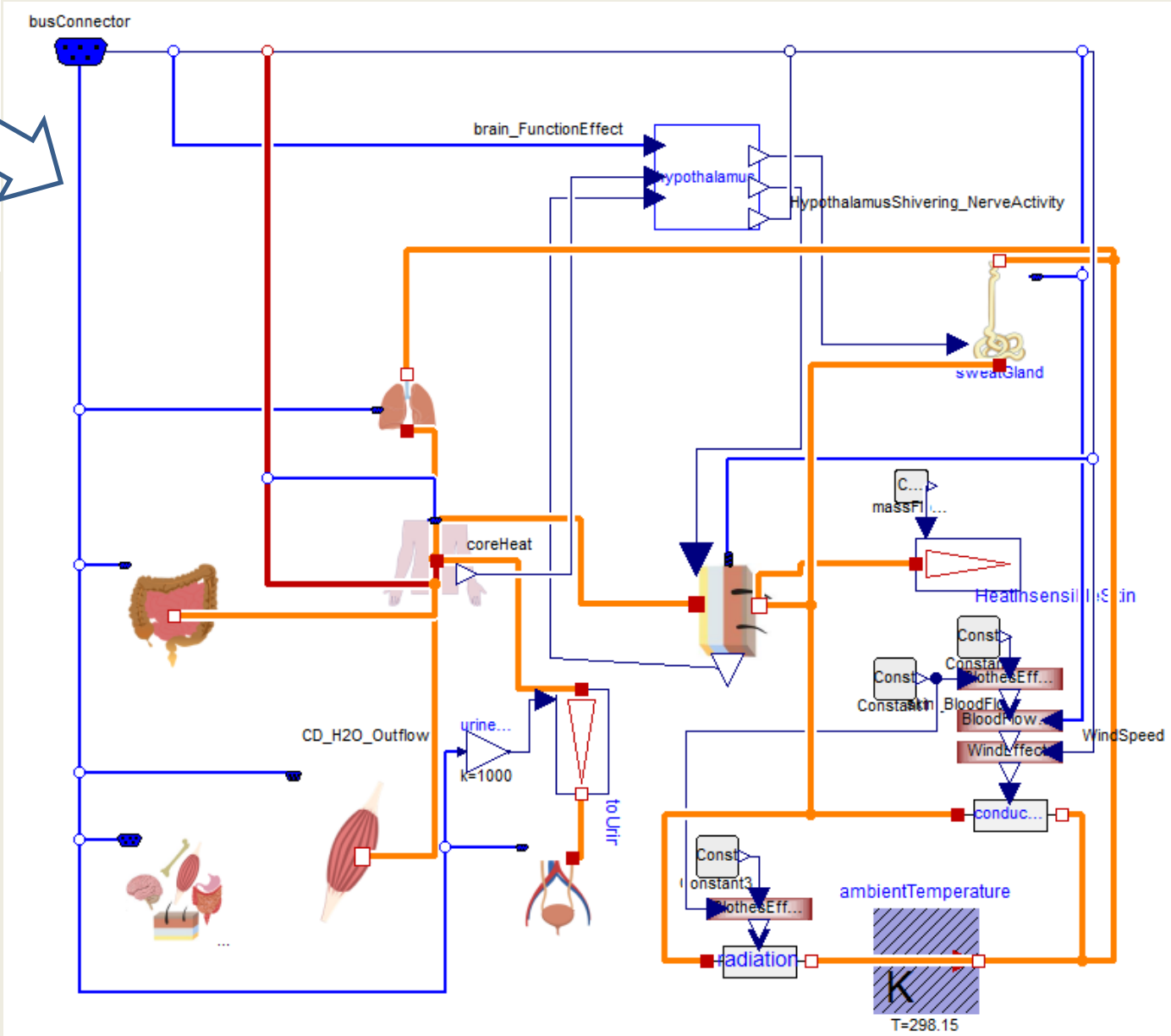
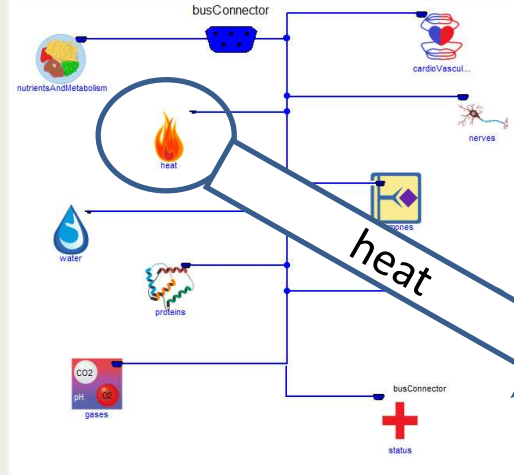

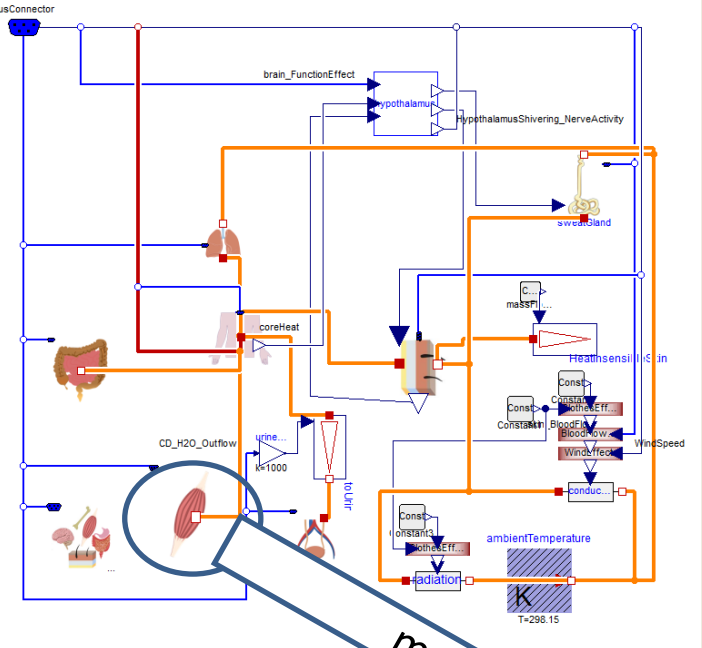

muscleheat

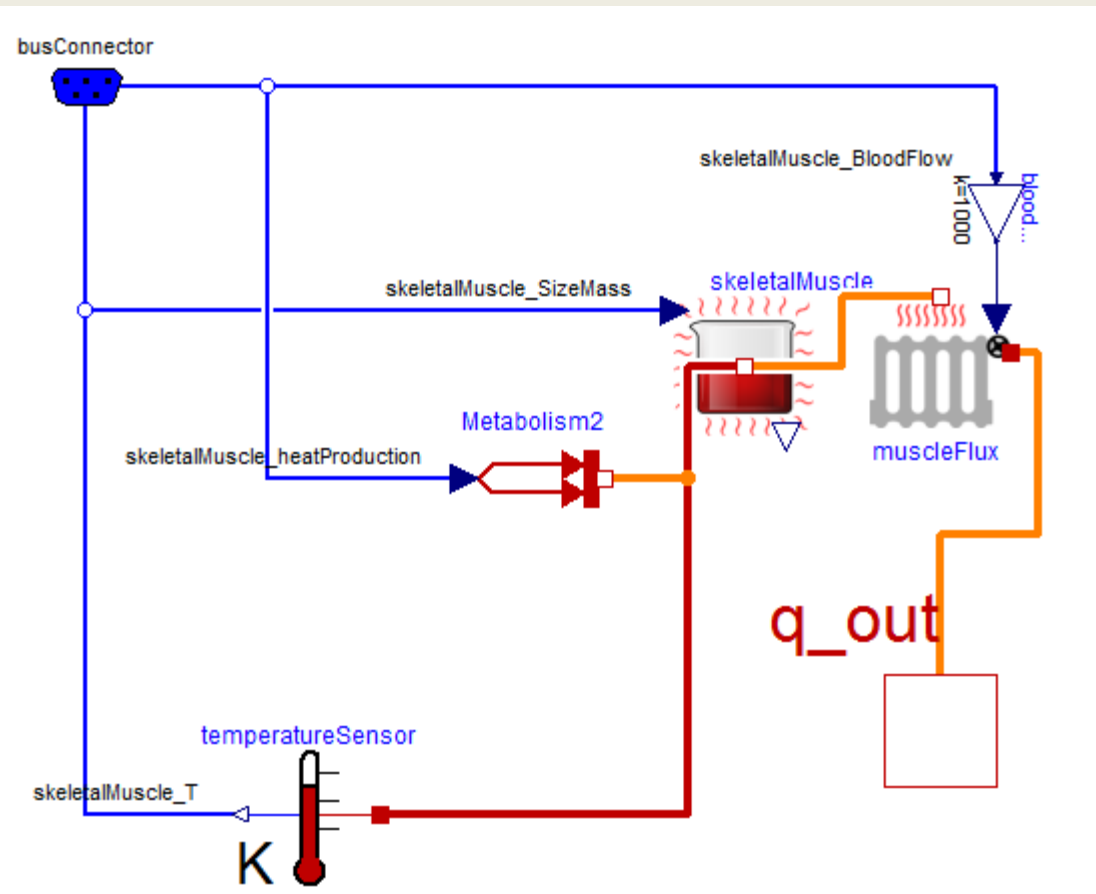

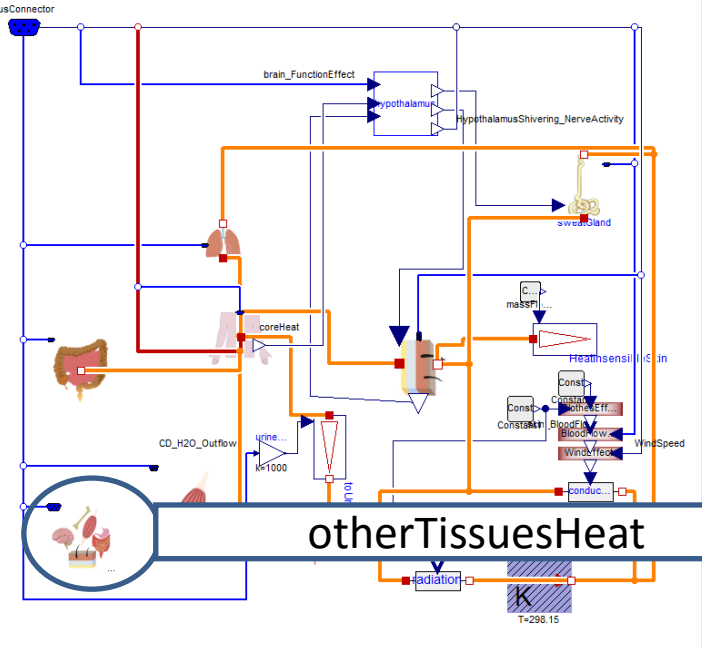

busConnector

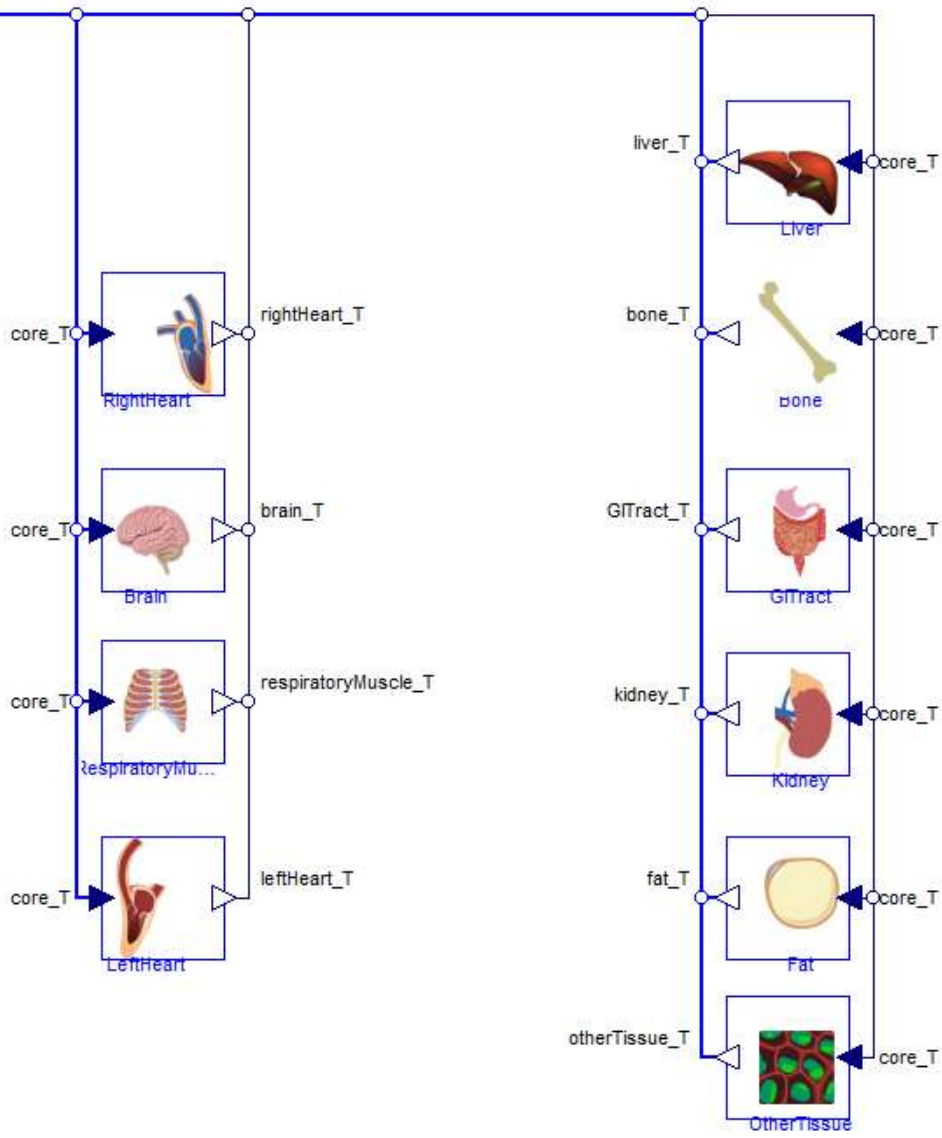
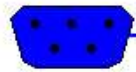

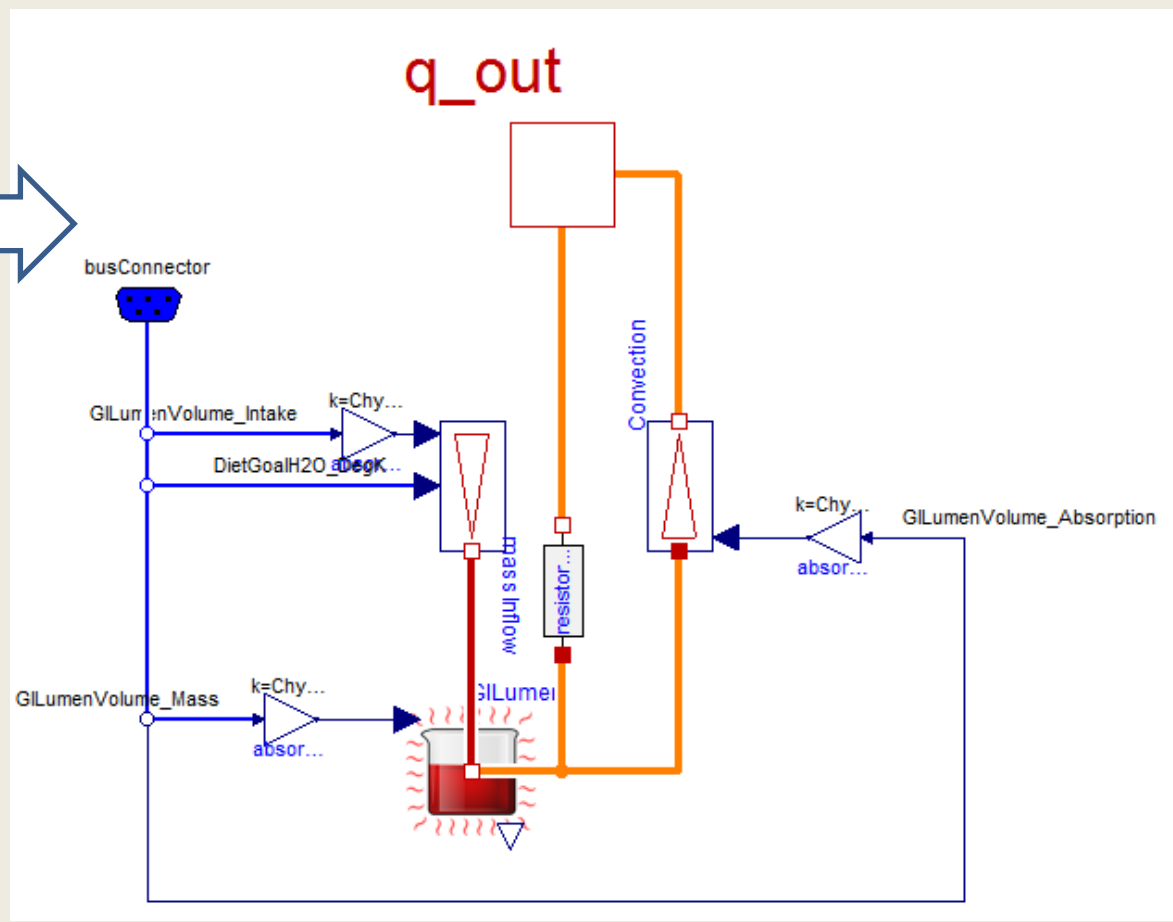
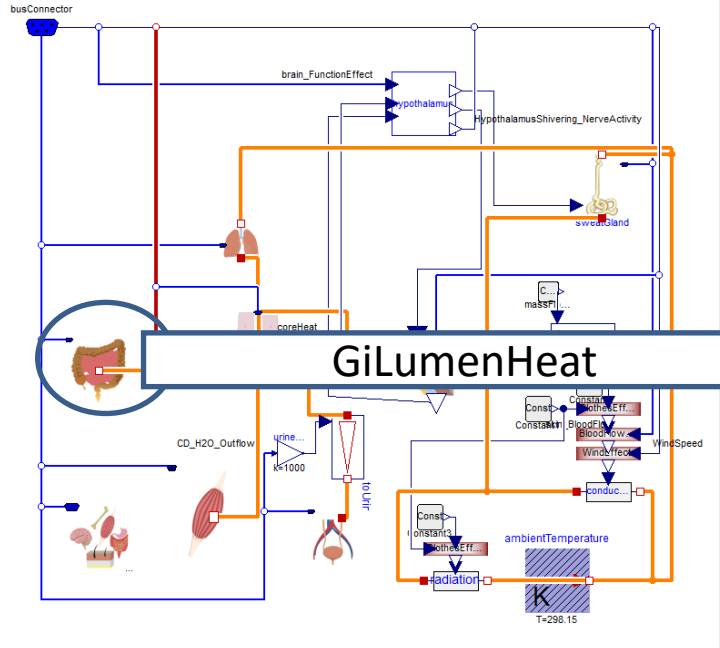

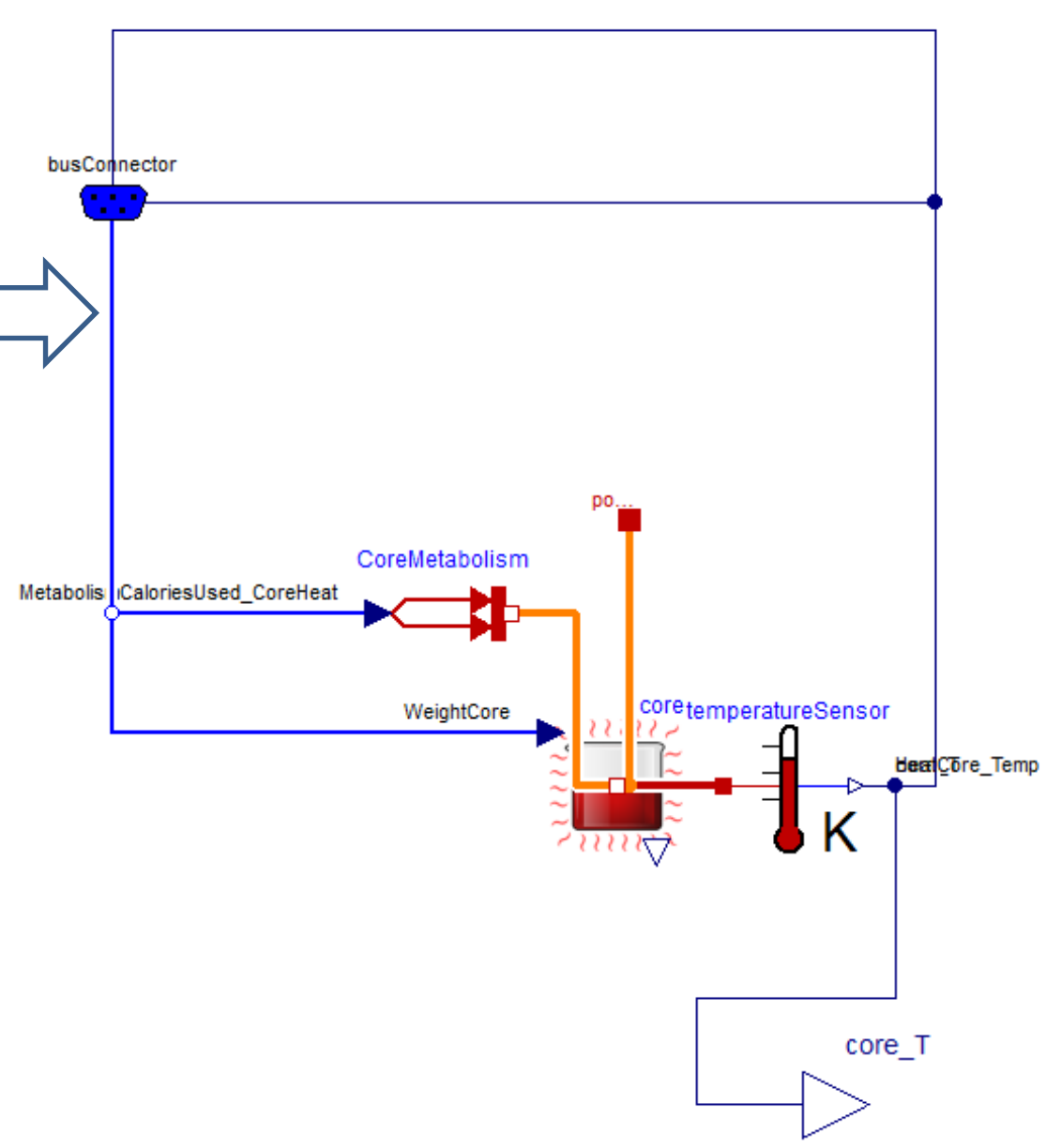
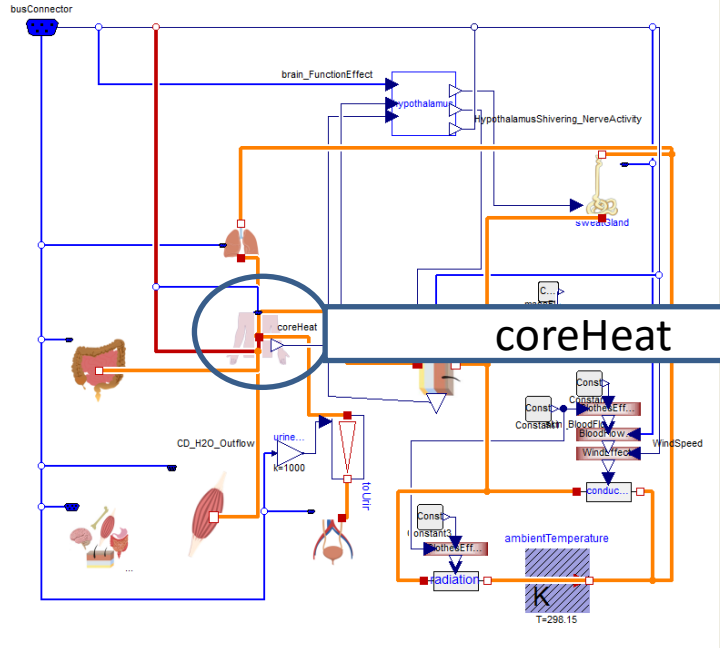

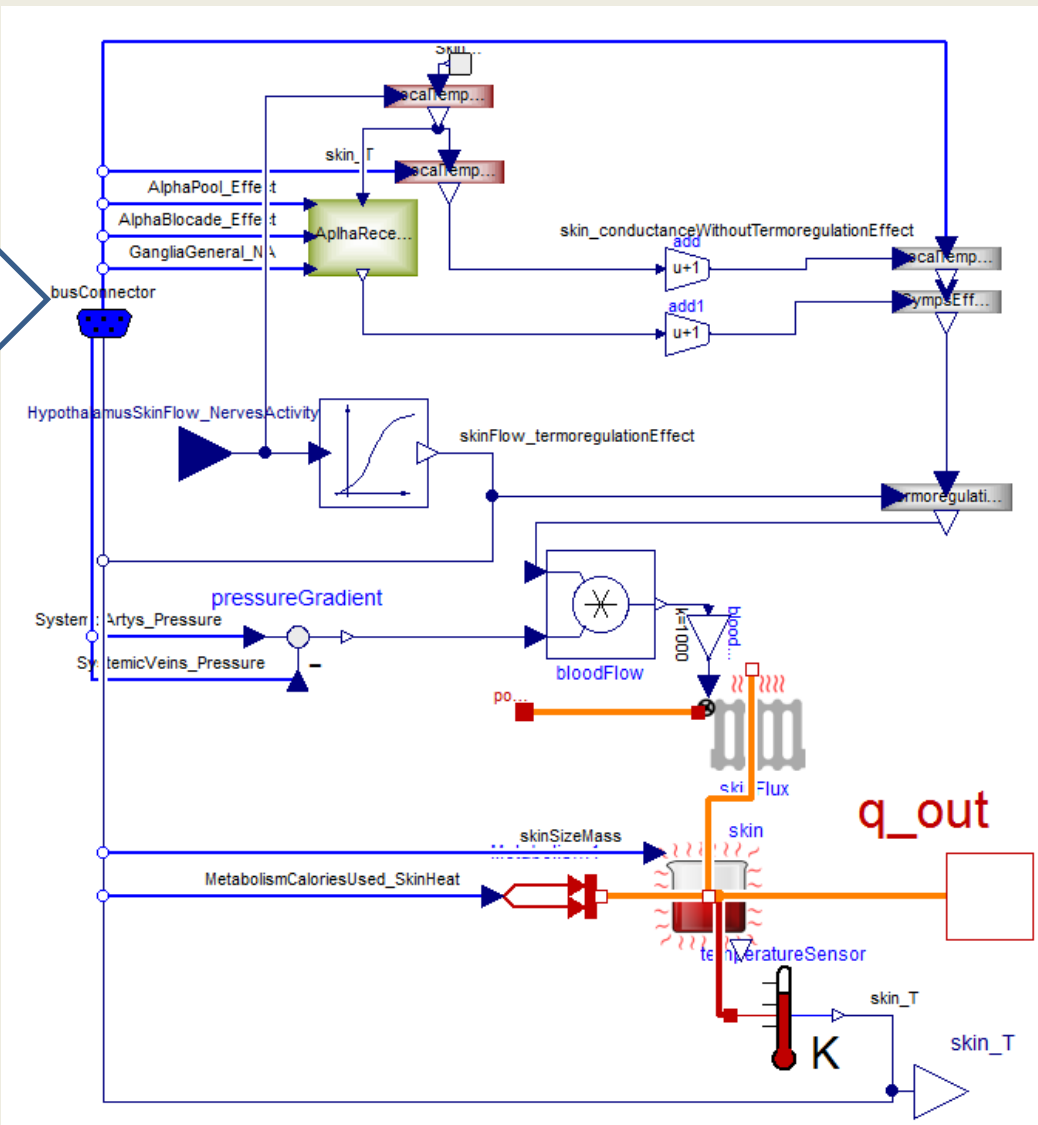
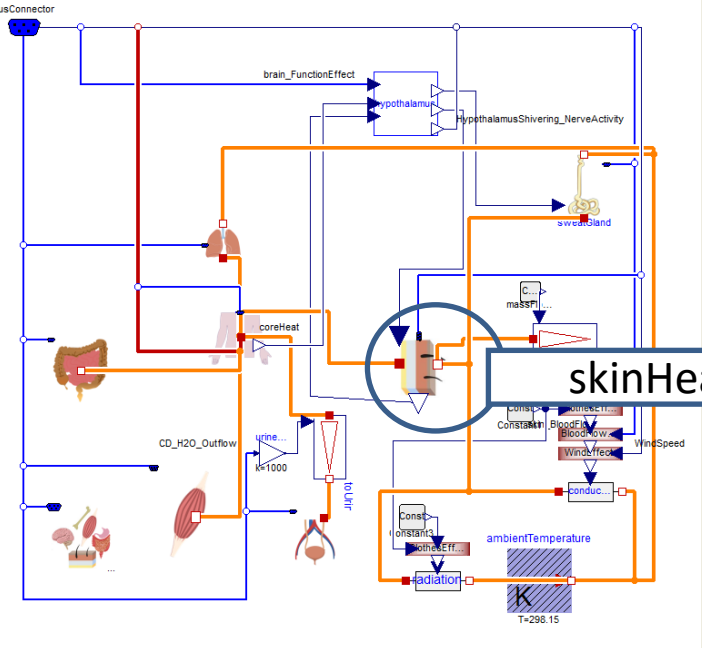

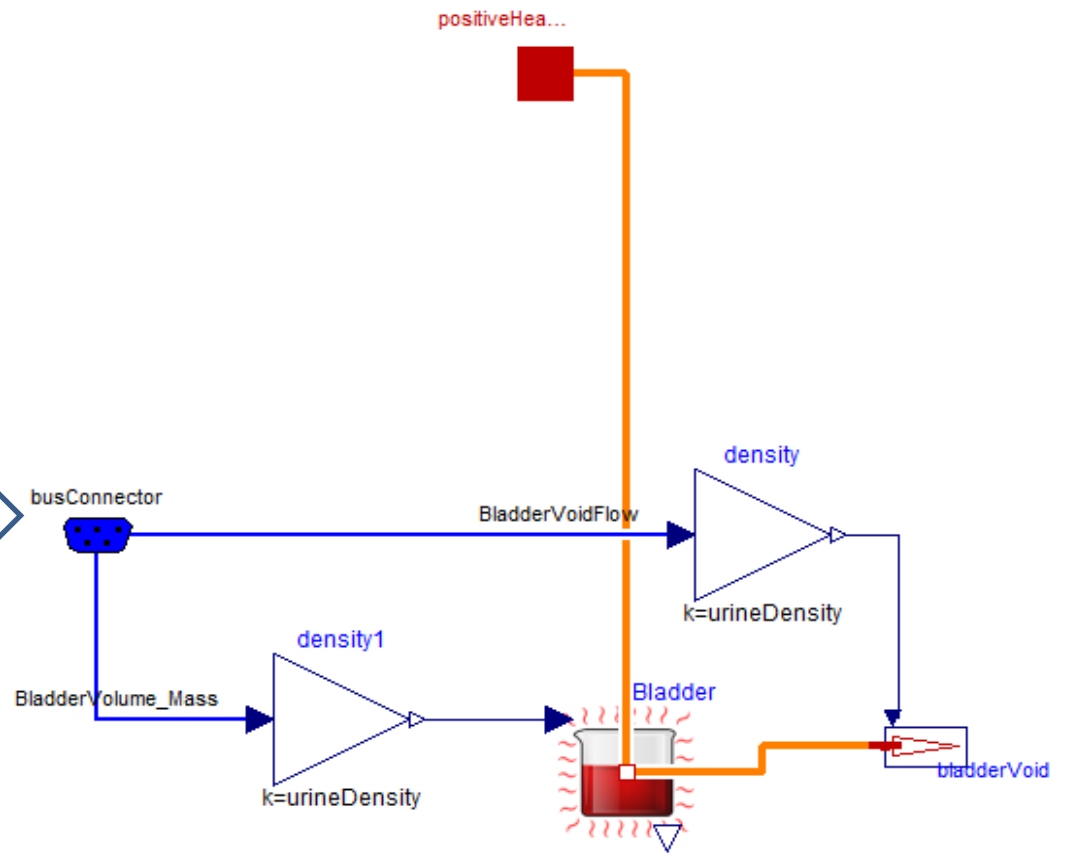
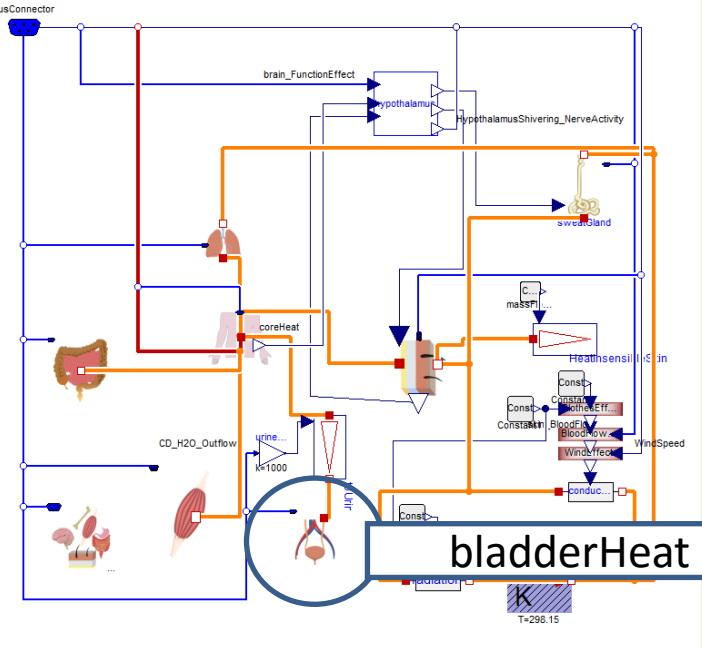

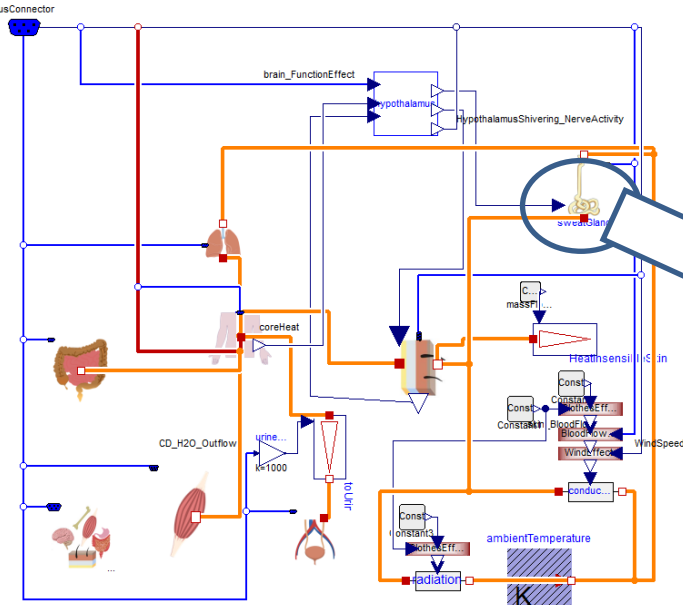

sweatGland

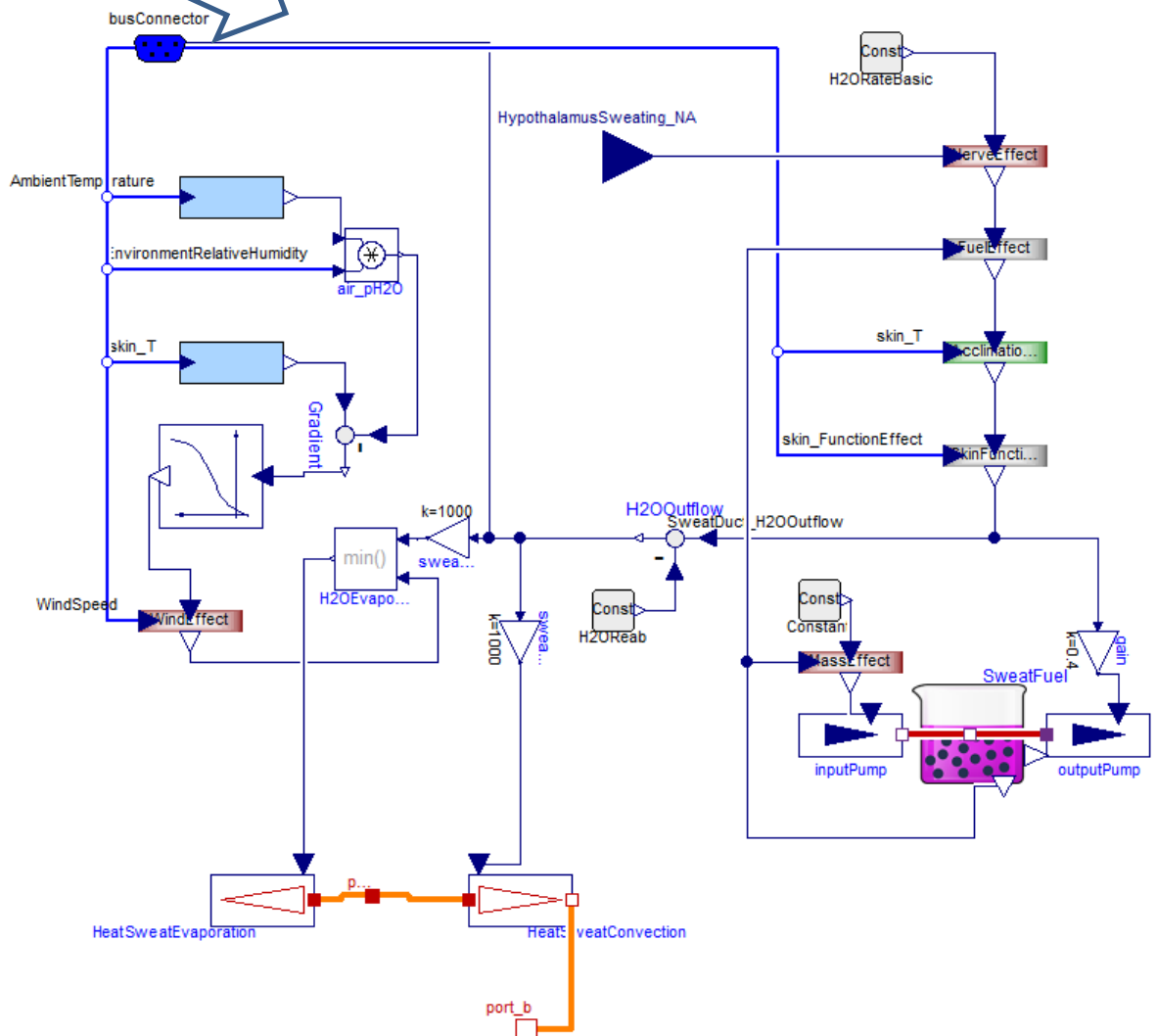

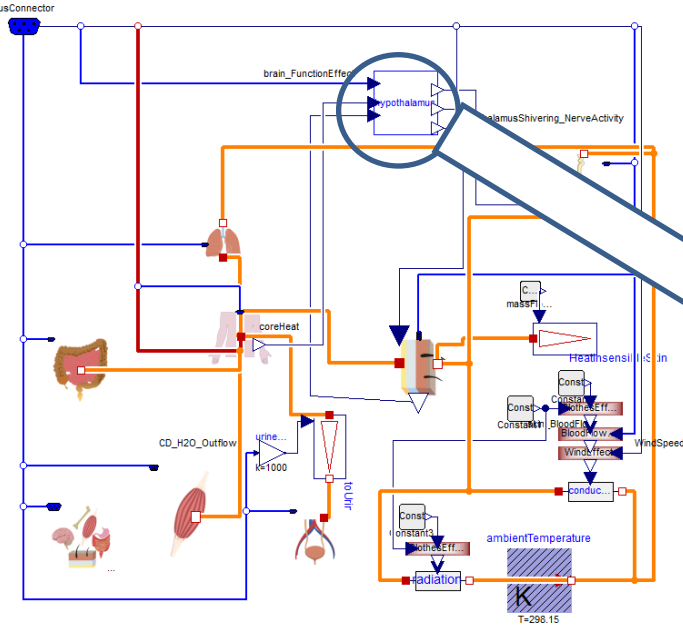

hypothalamus

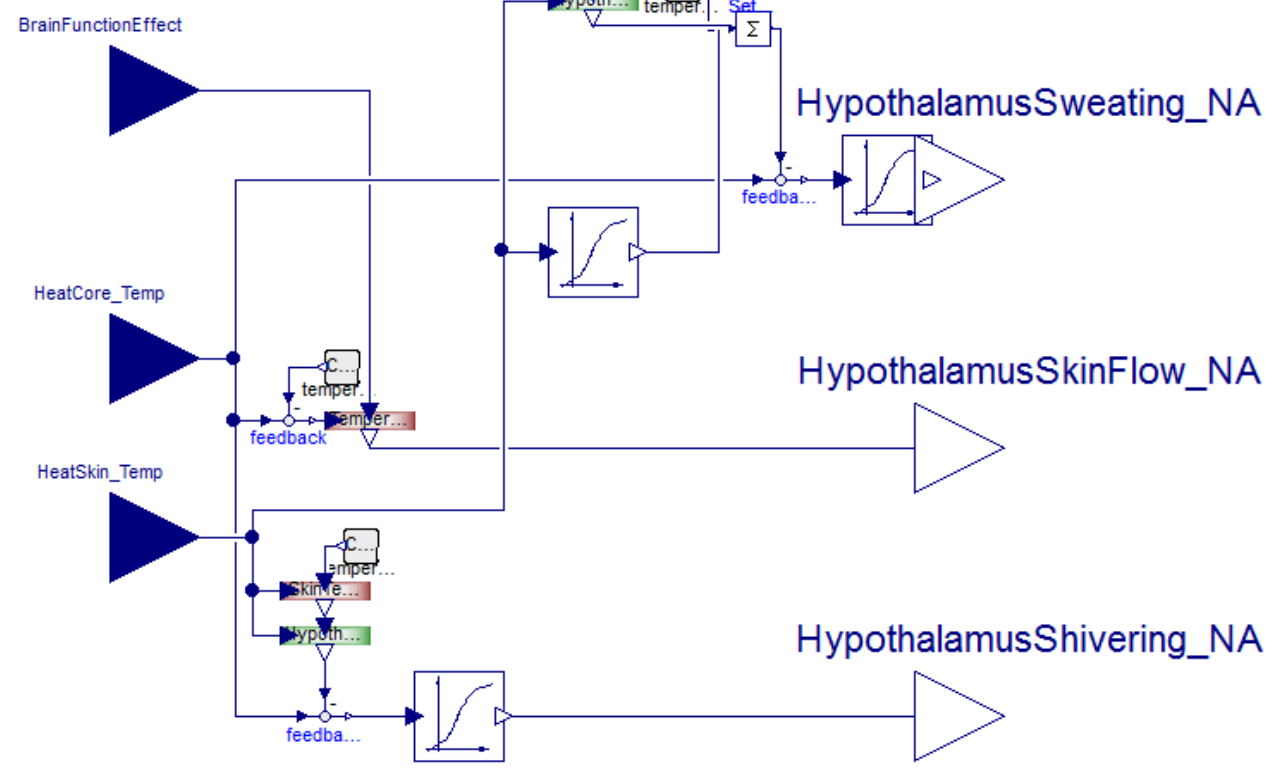

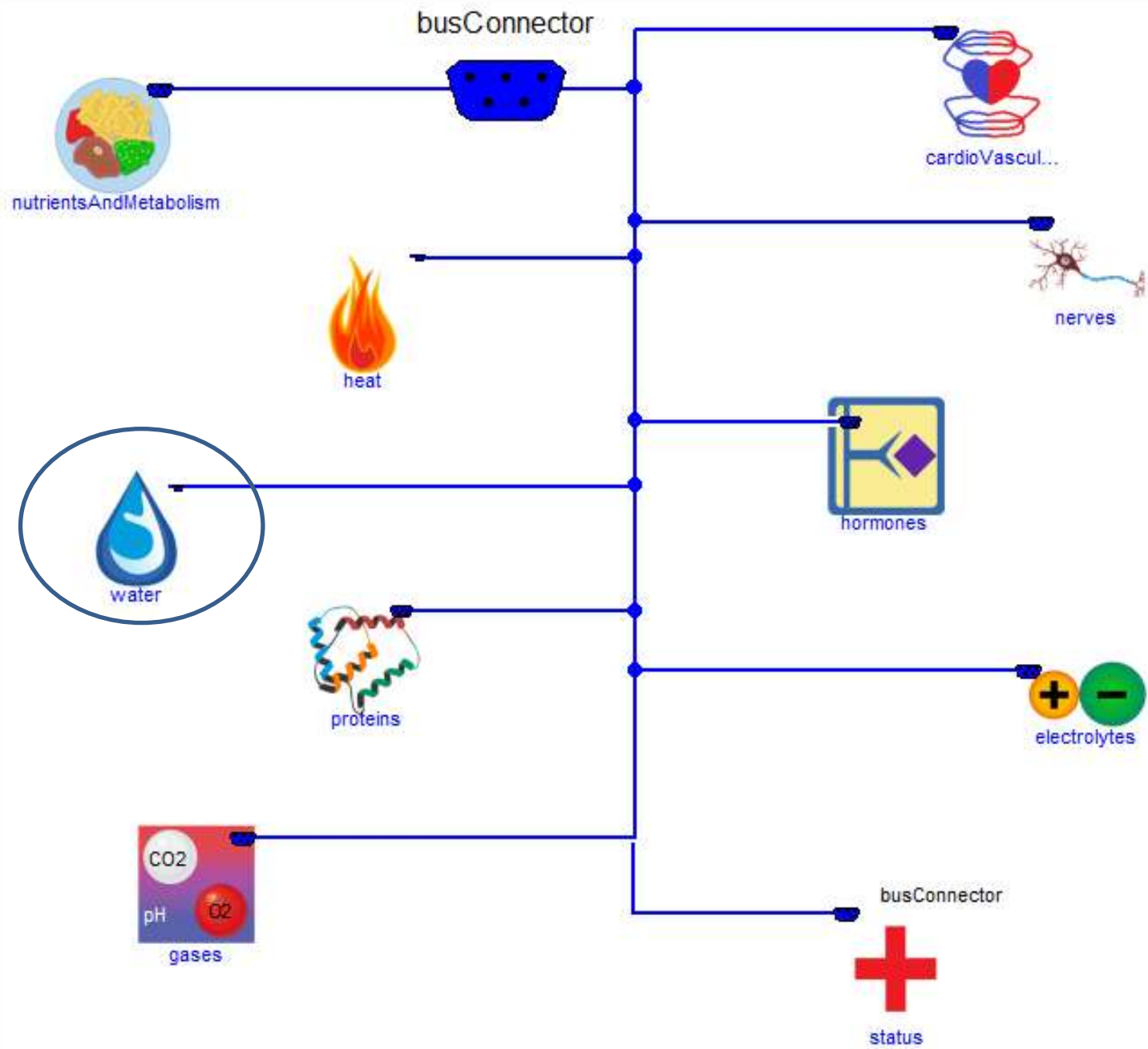

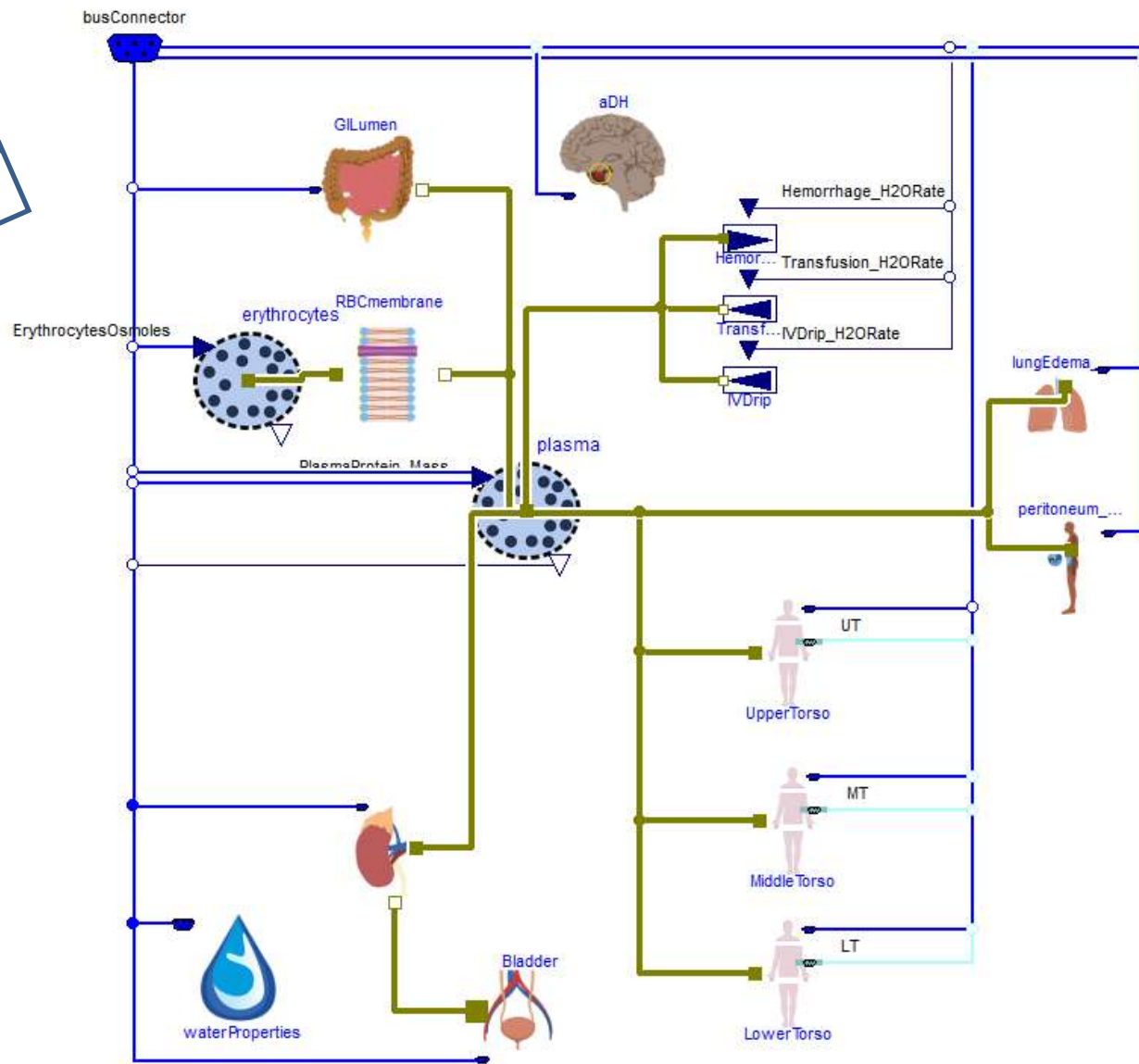
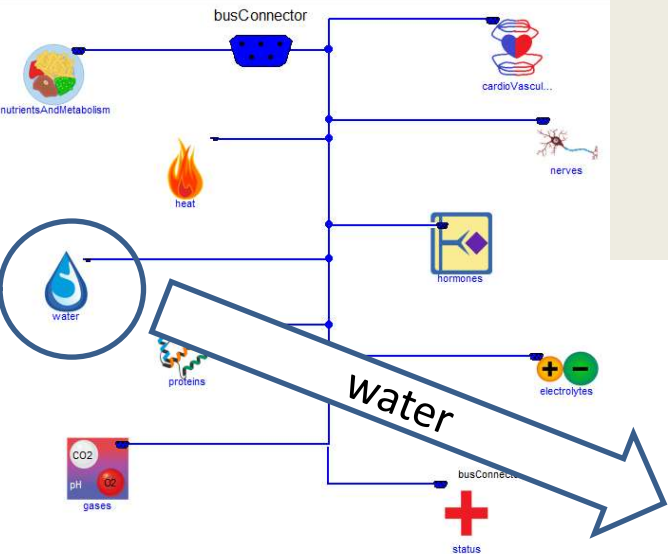

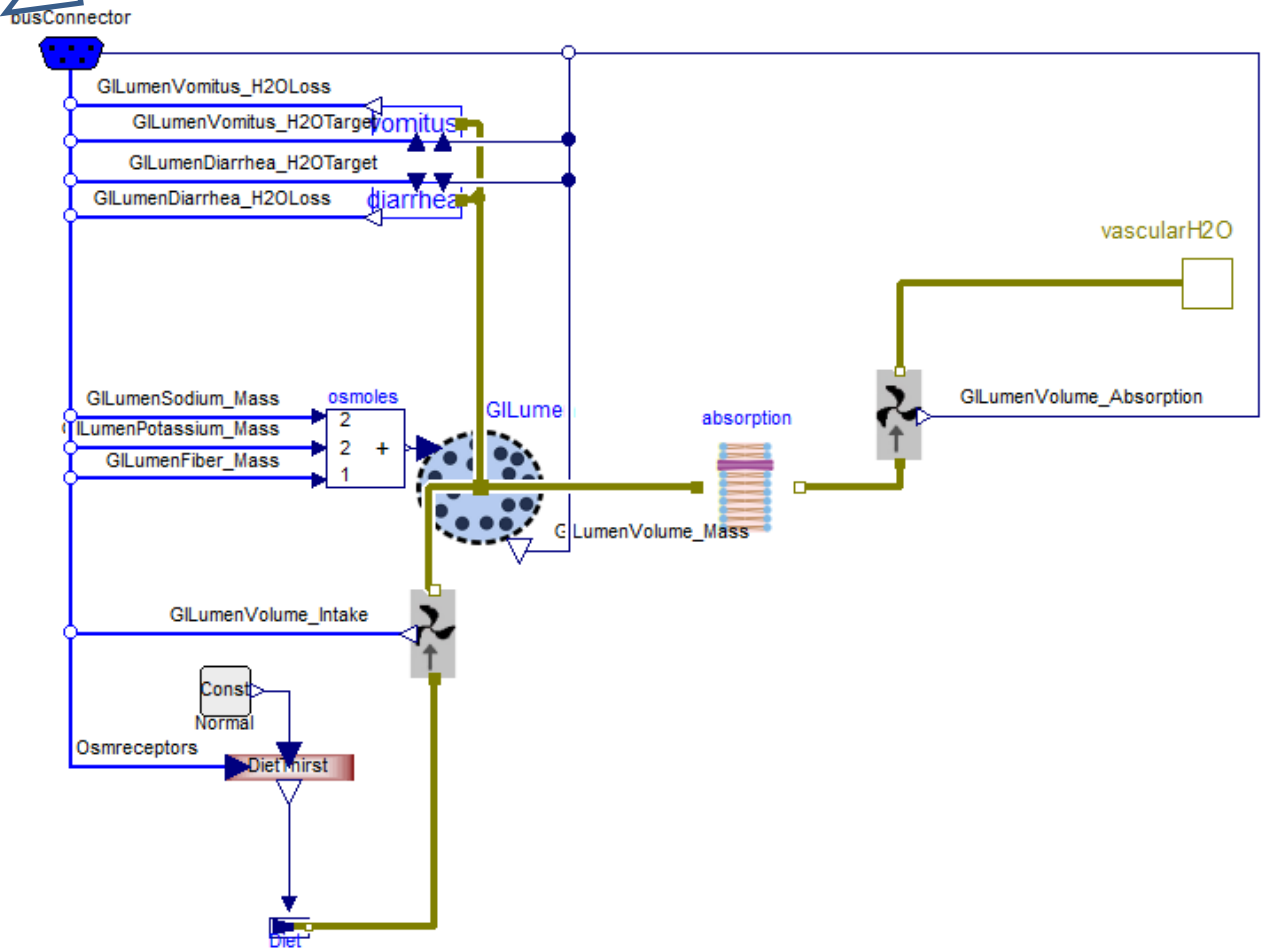
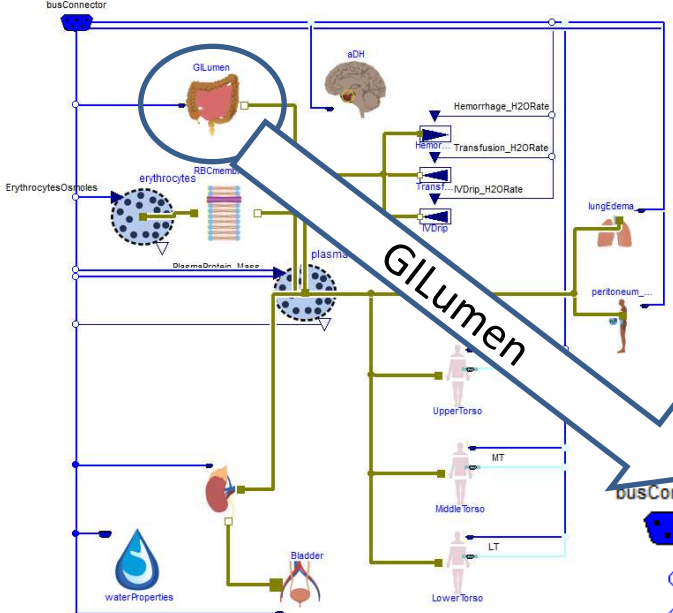

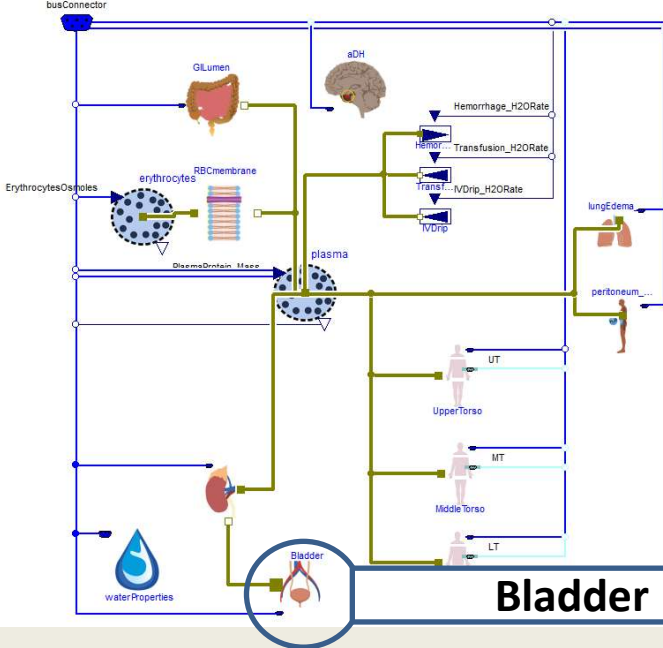

Bladder

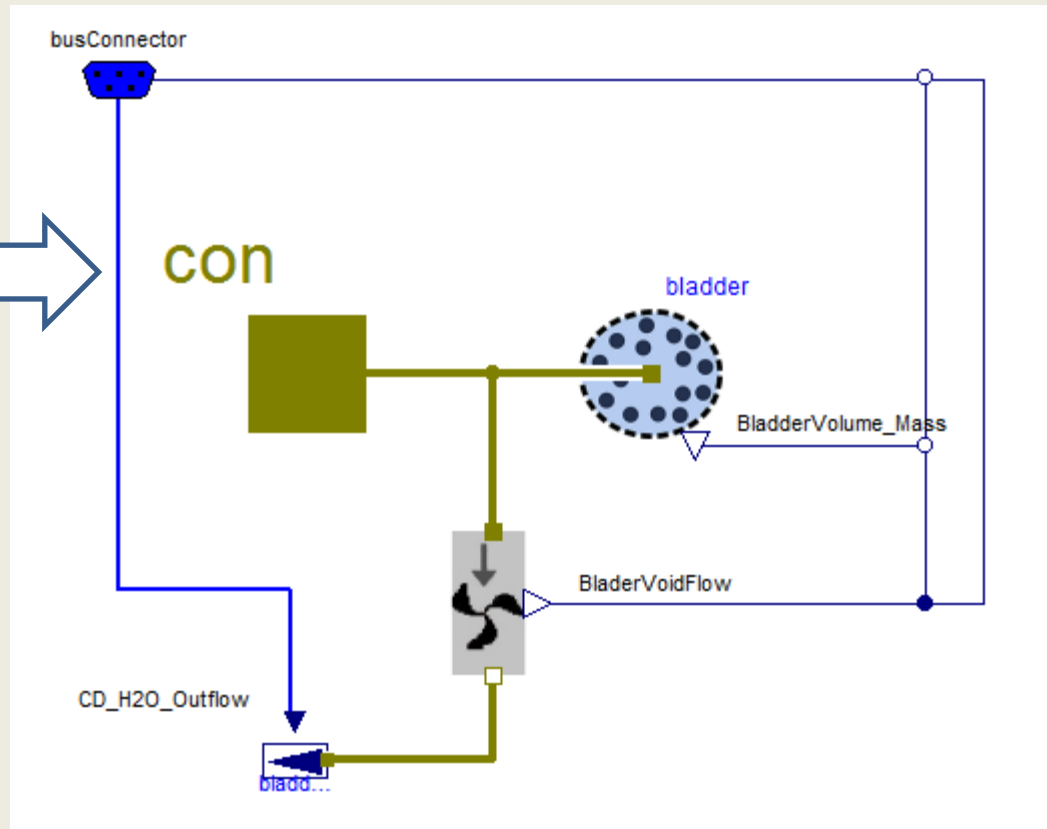

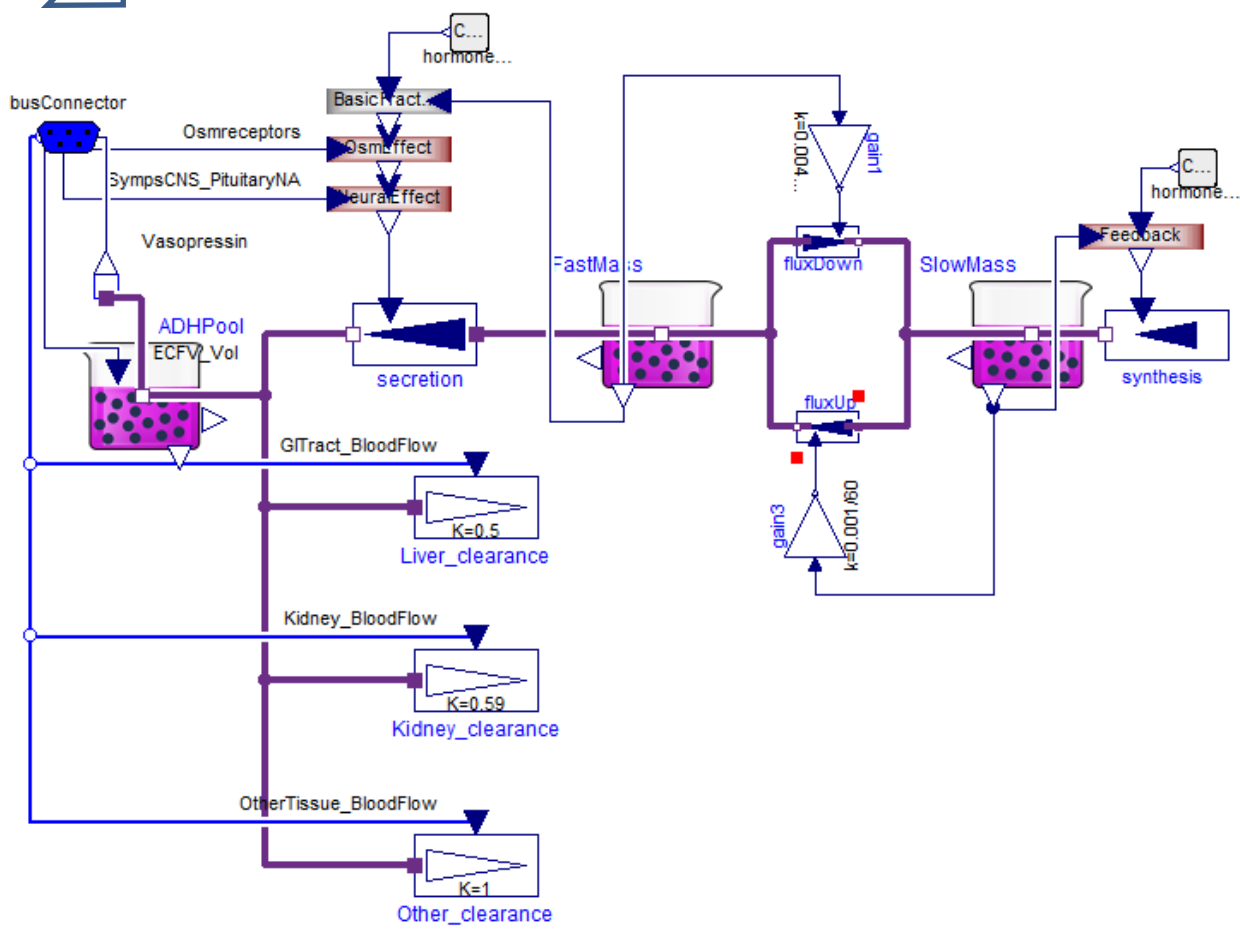
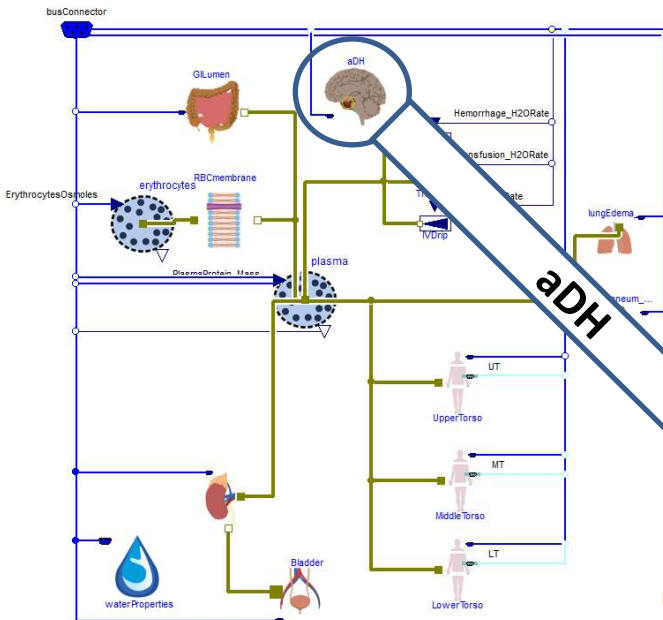

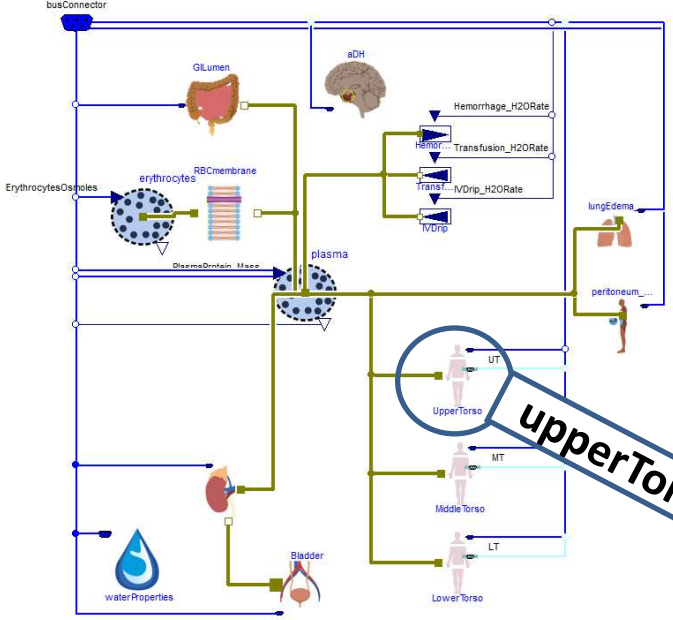

upperTorso

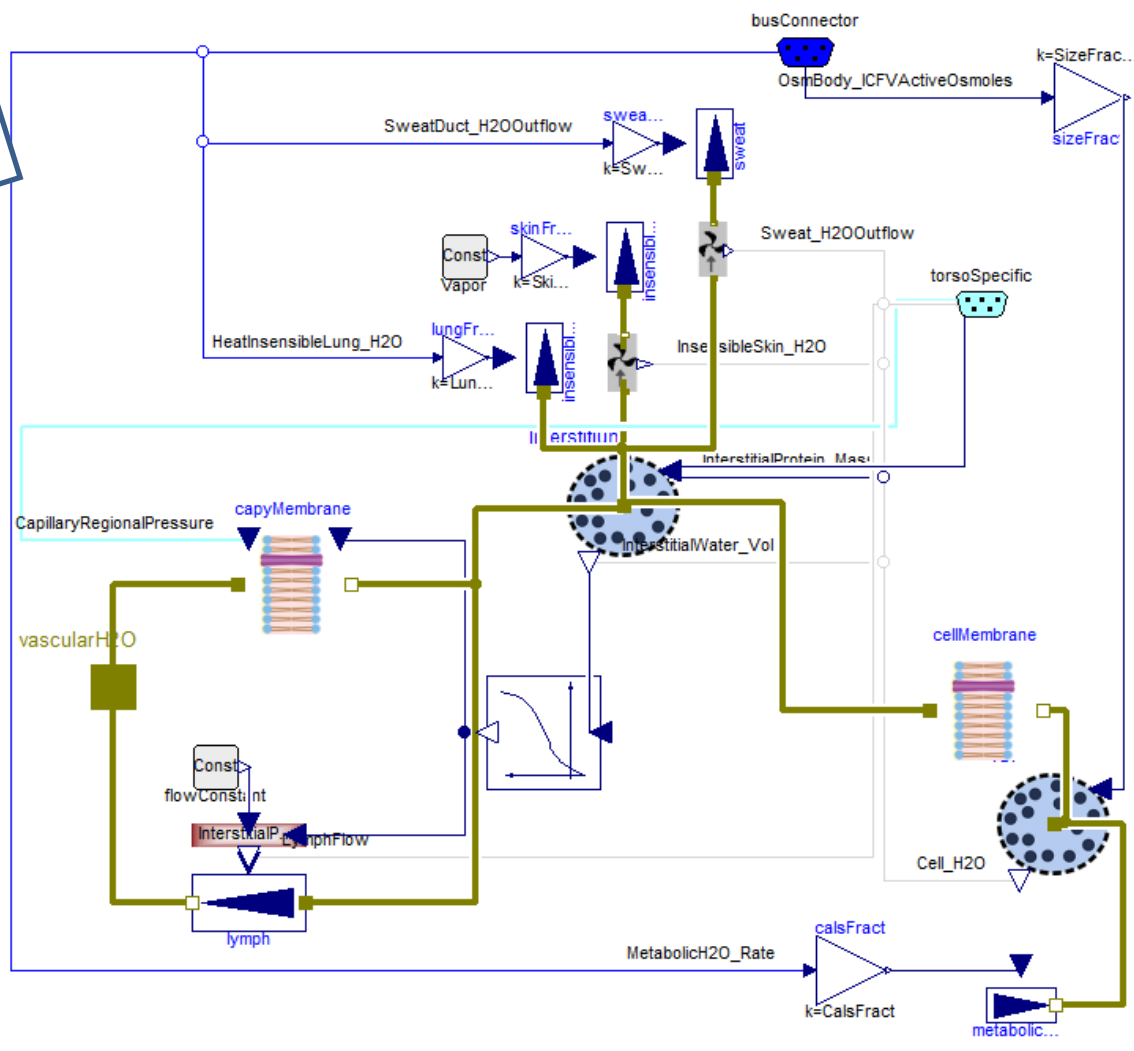

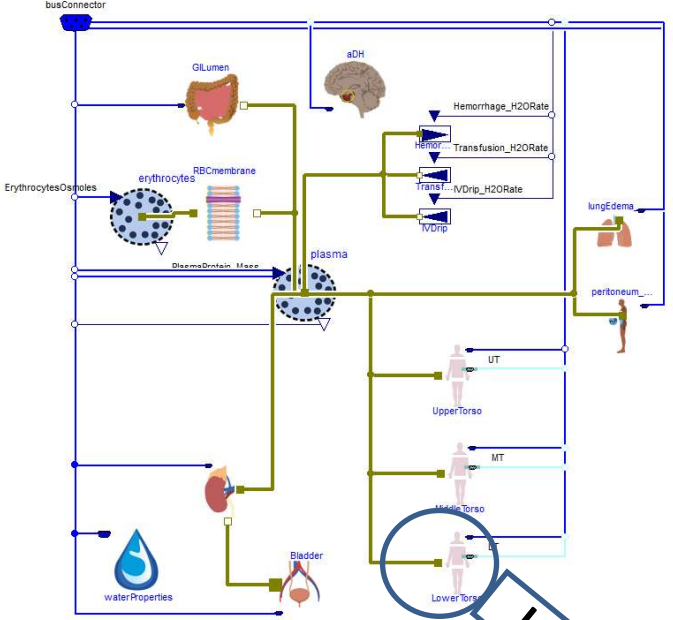

lowerTorso

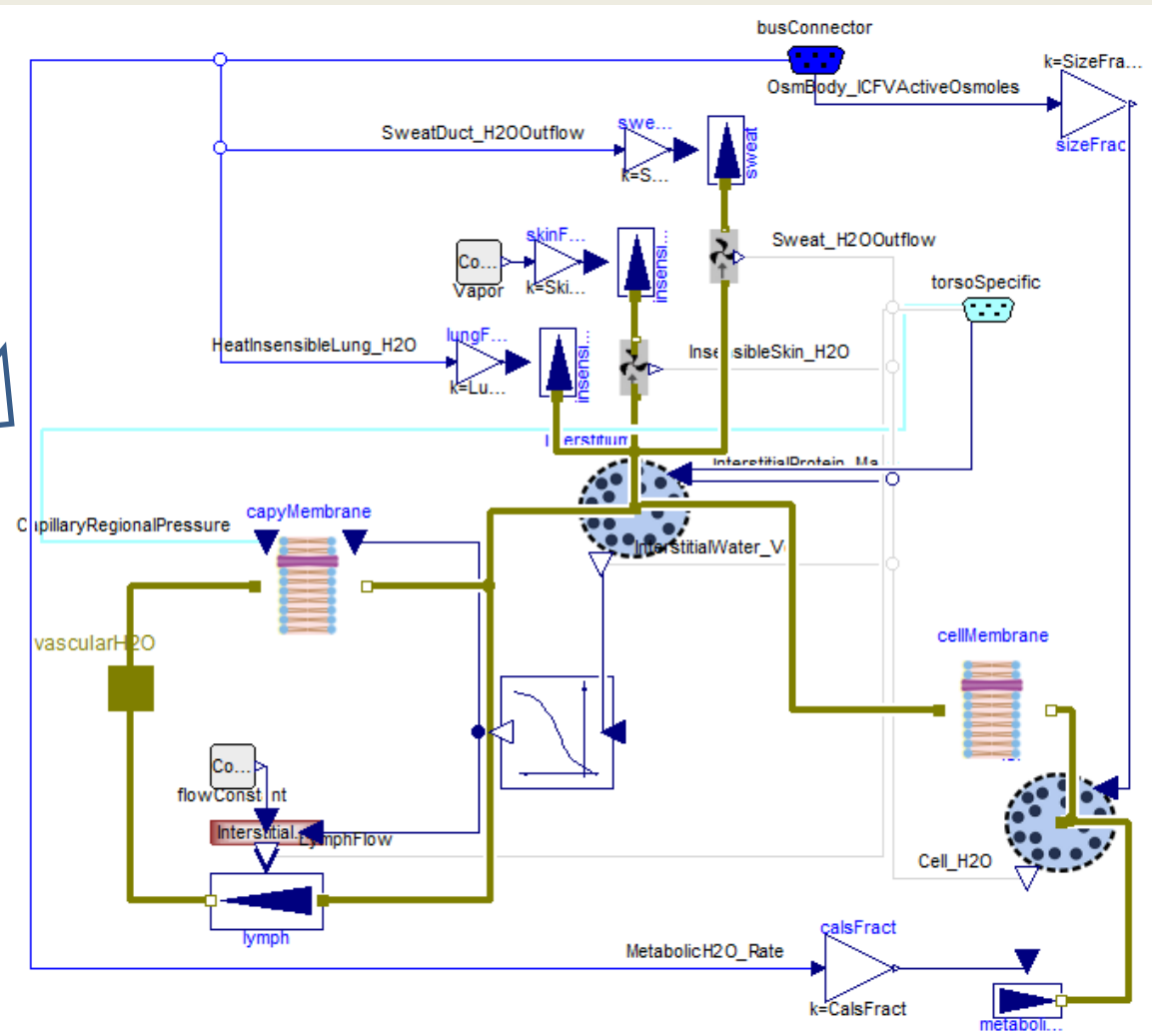

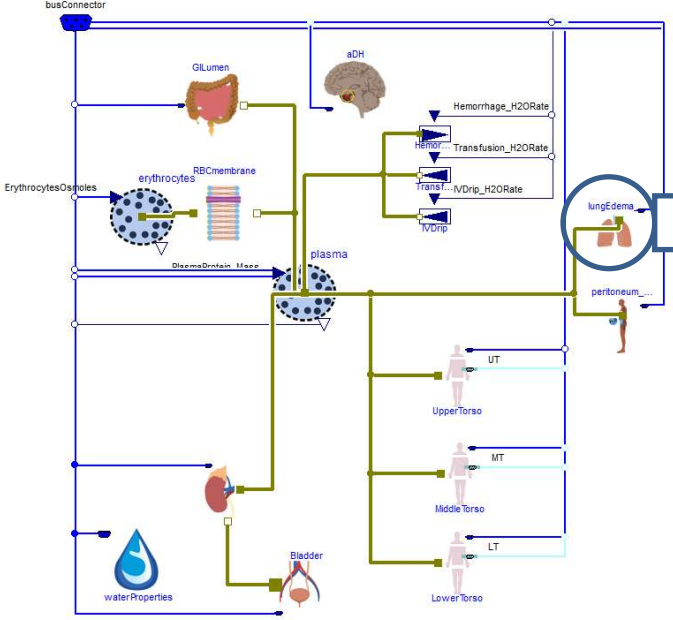

lungEdema_const

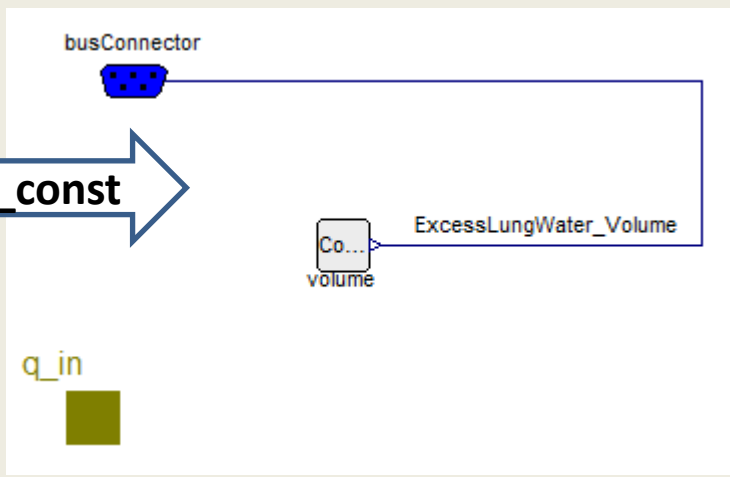

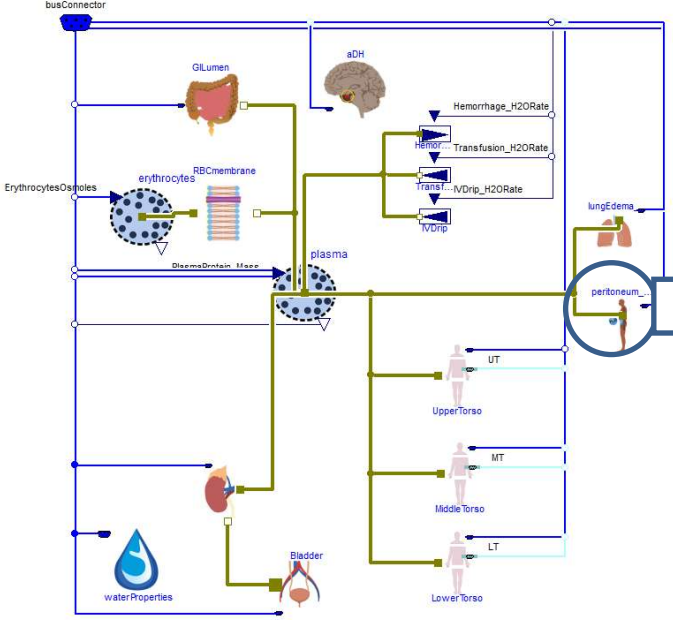

Peritoneum_const

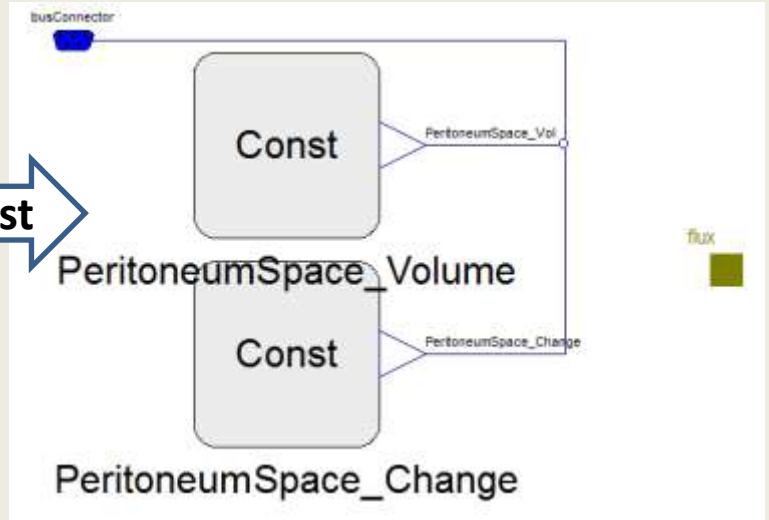

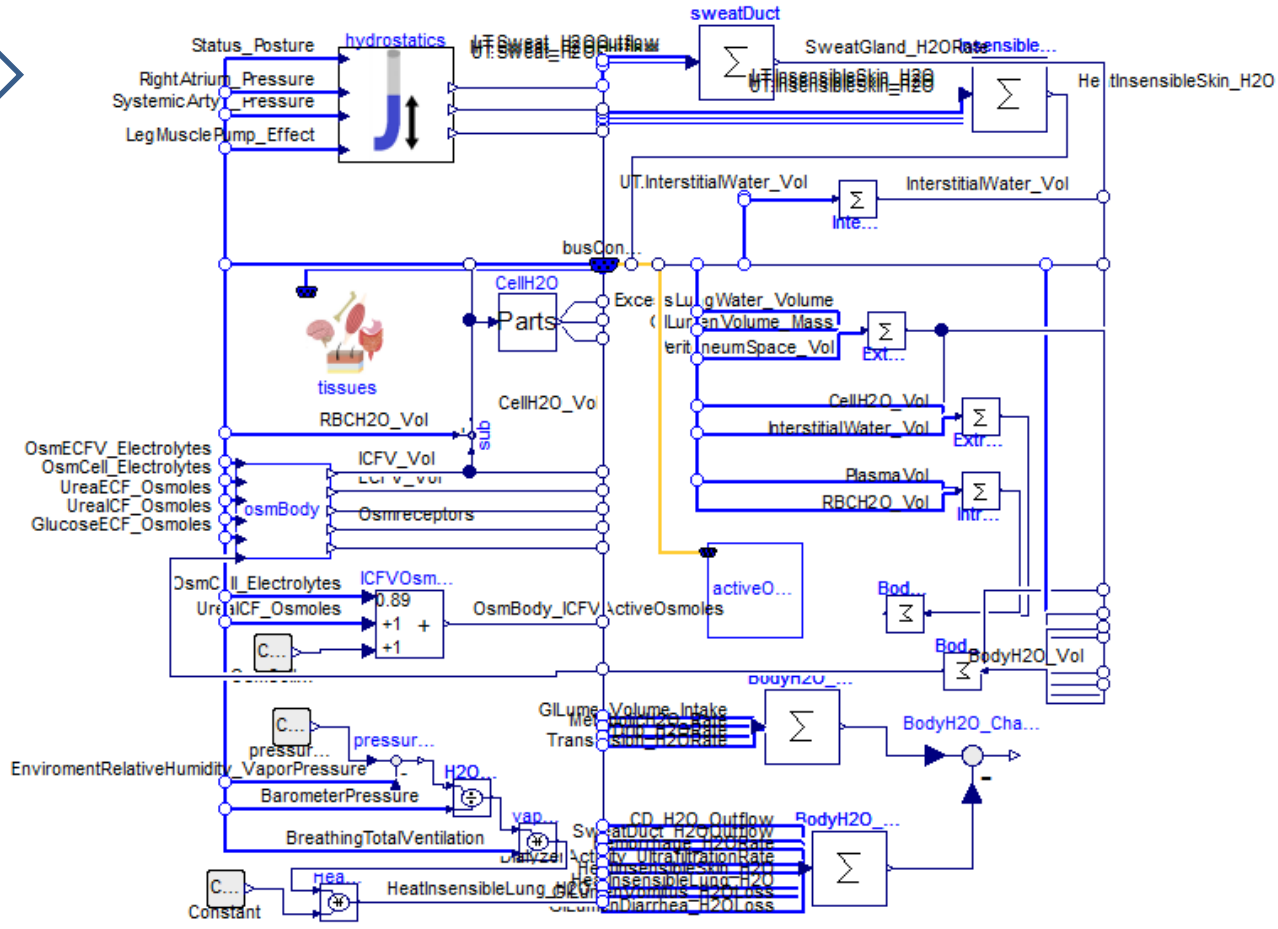
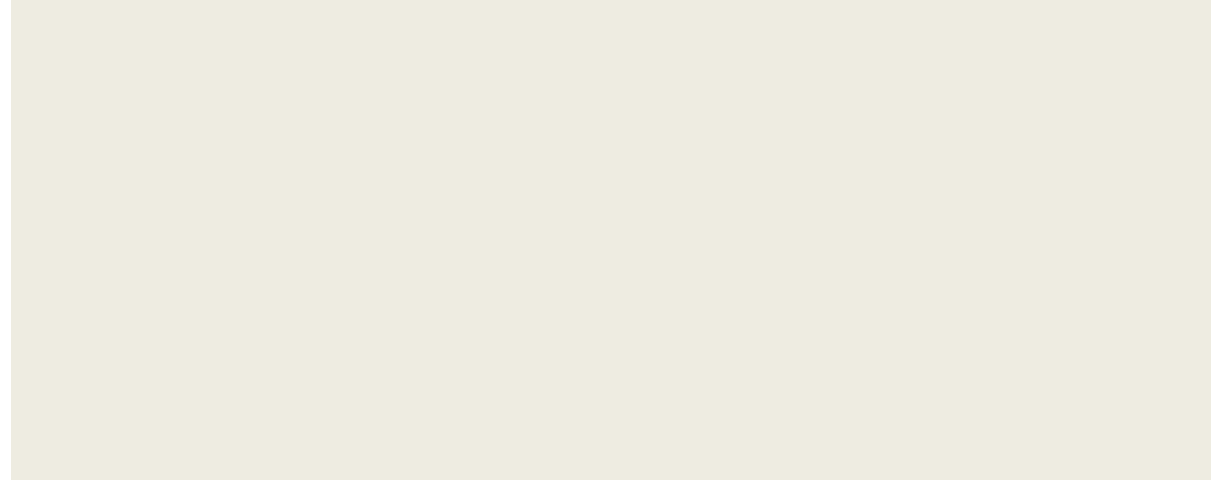
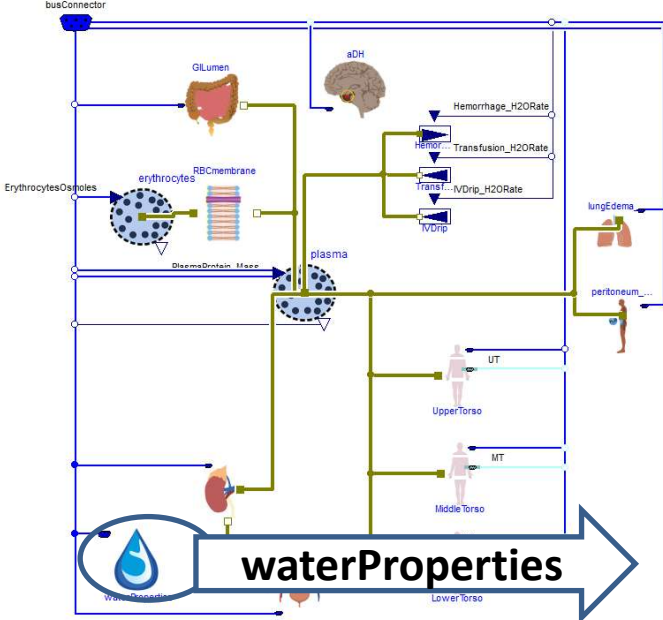

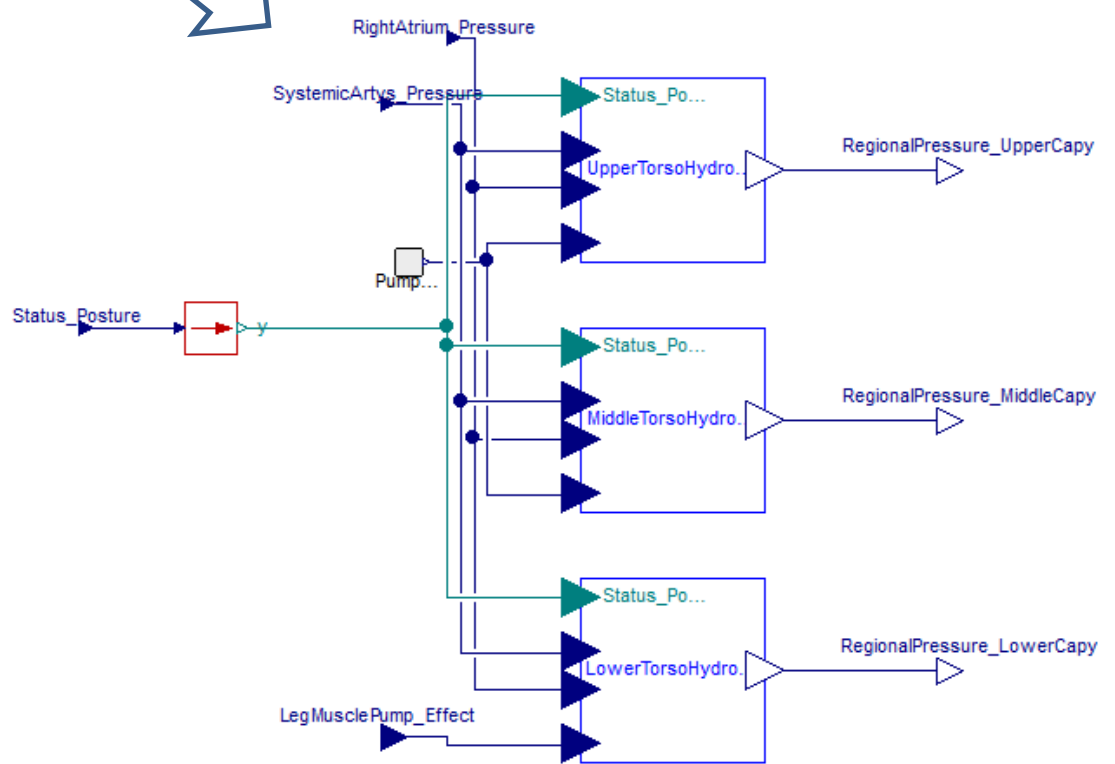
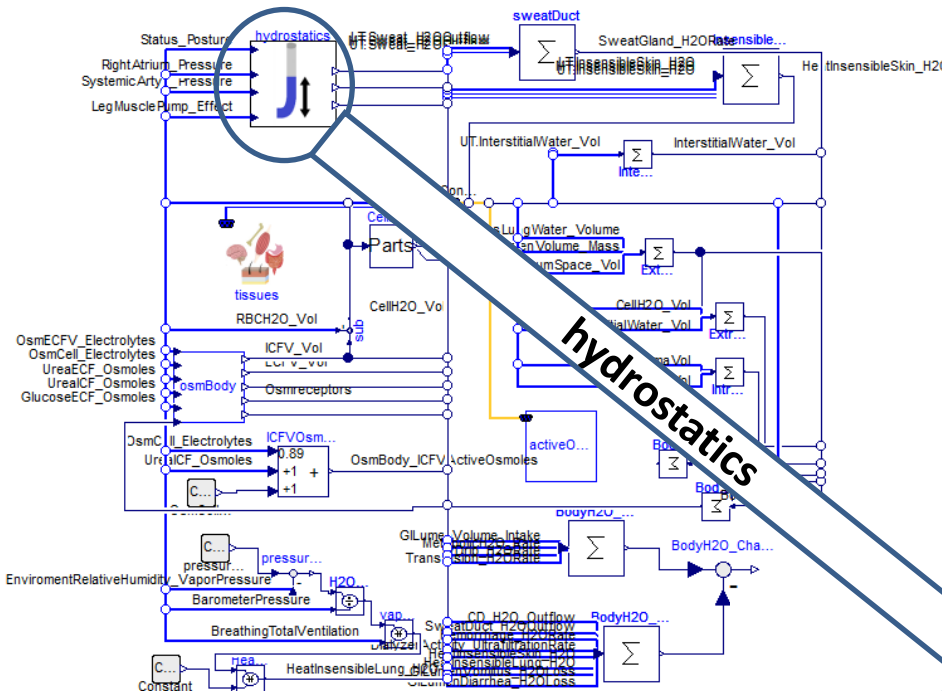

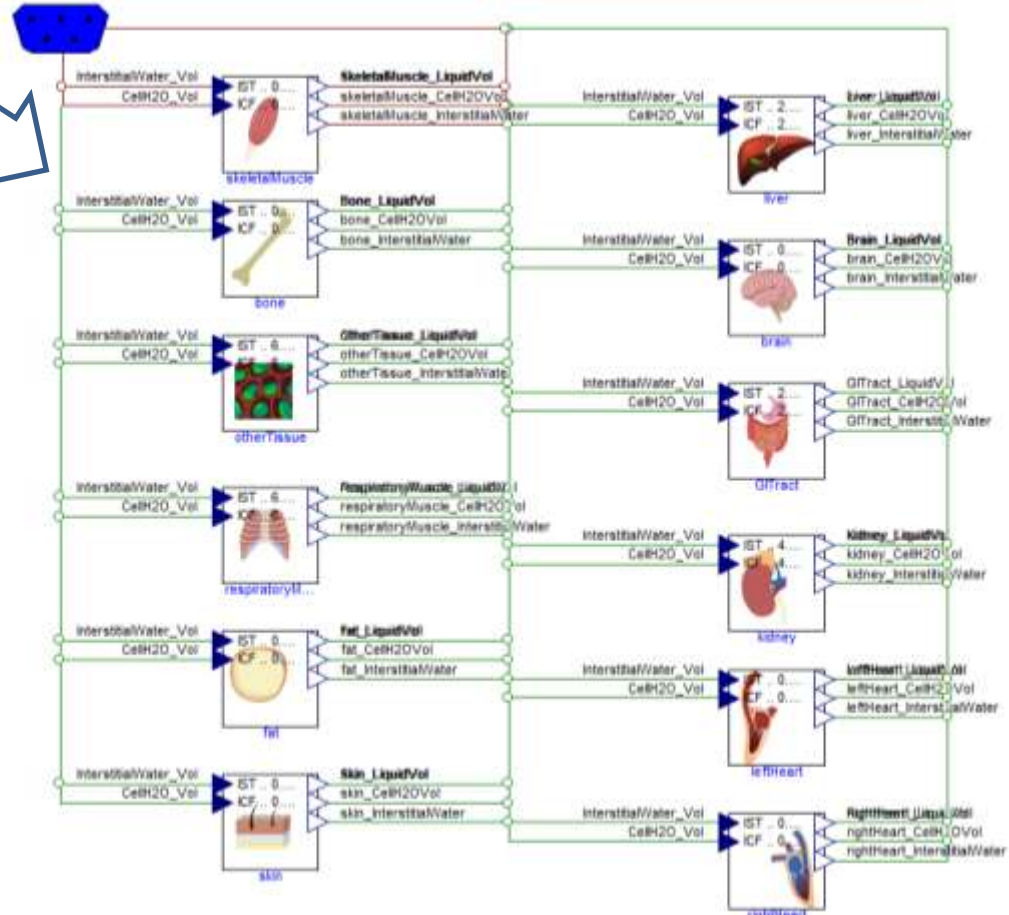
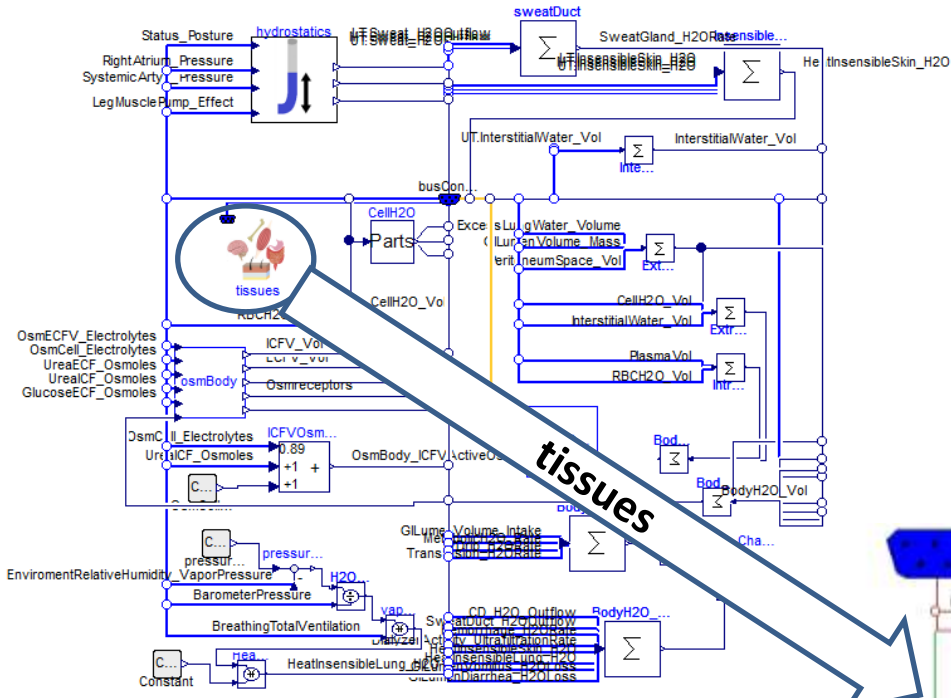

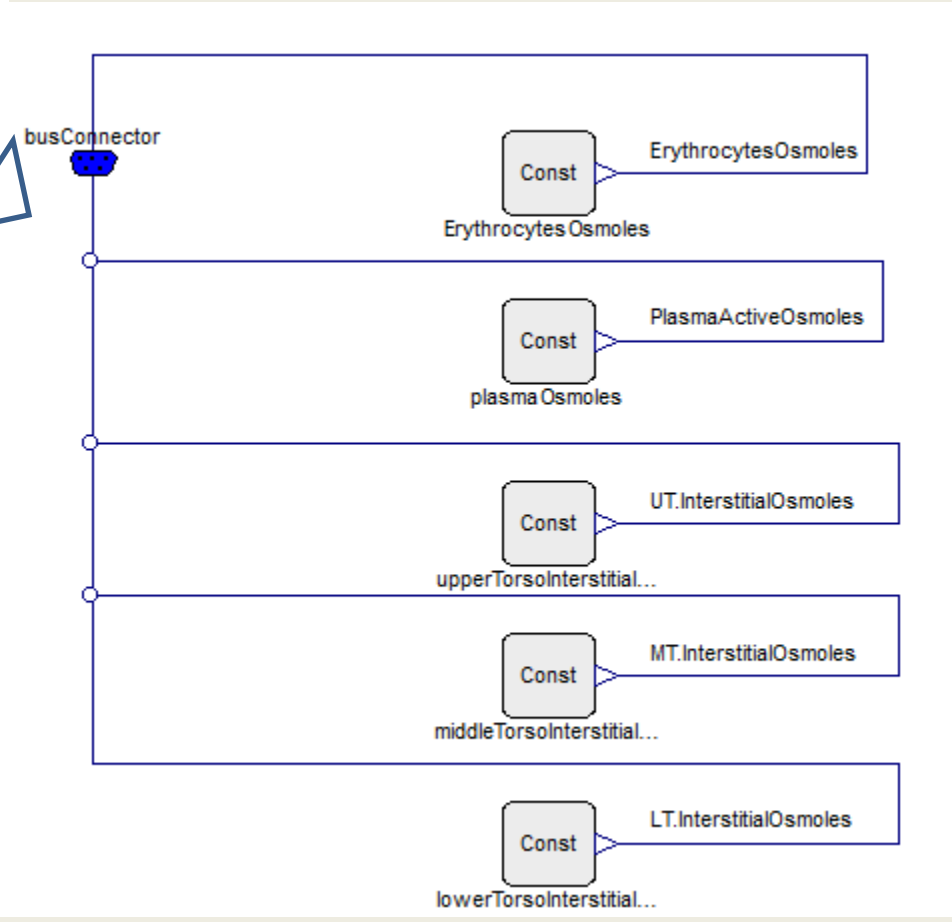
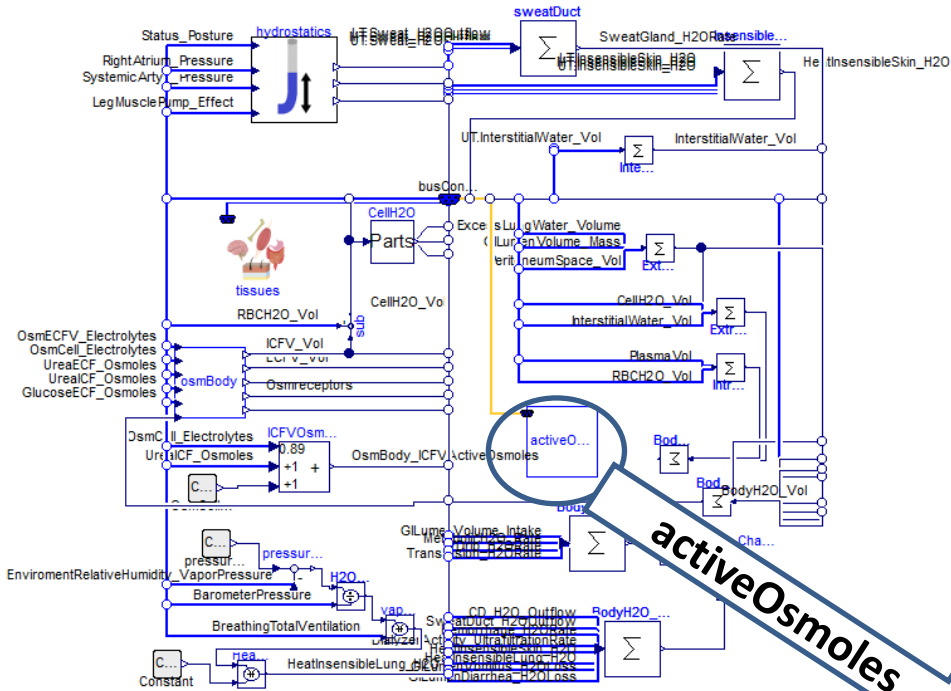

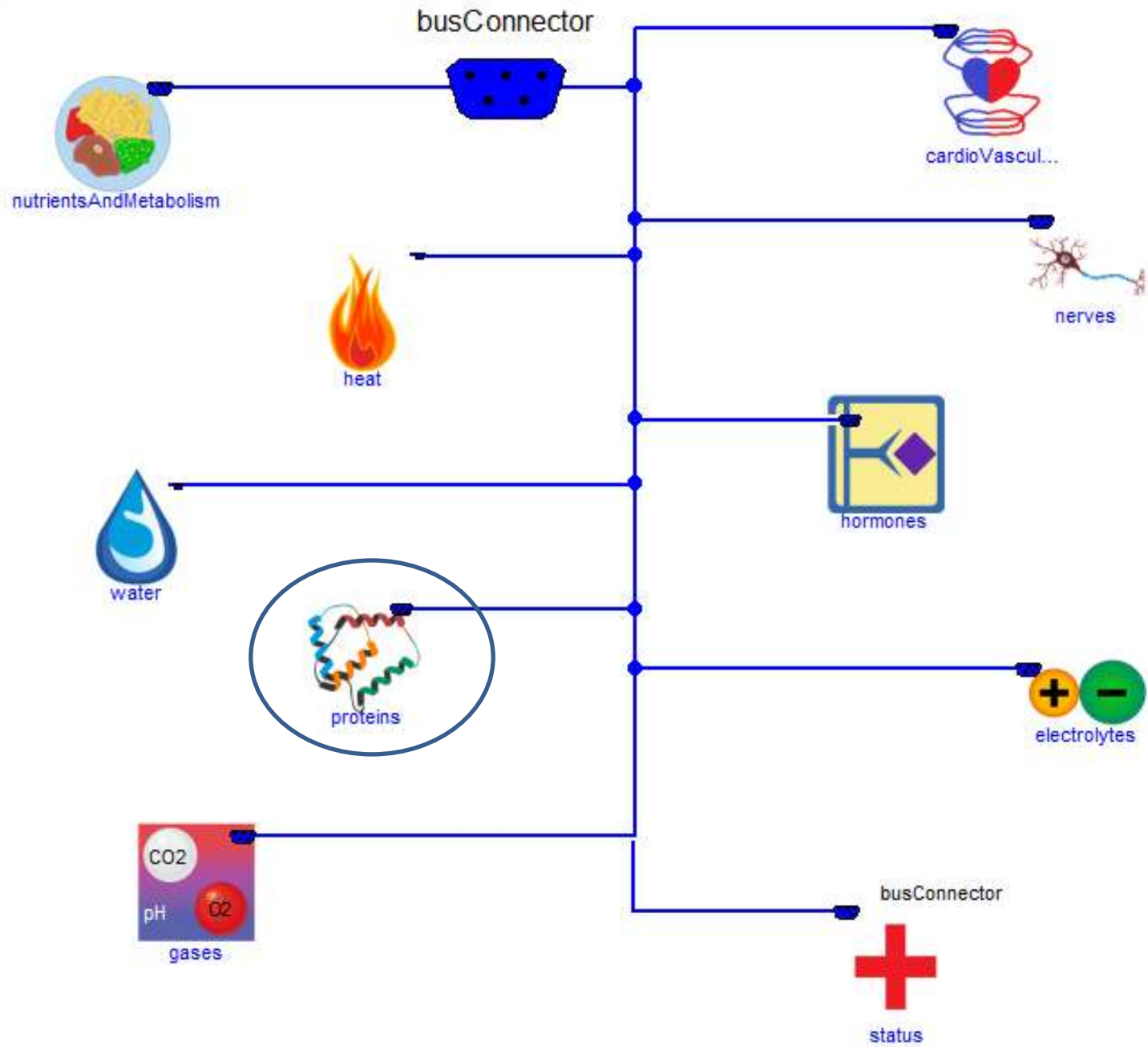

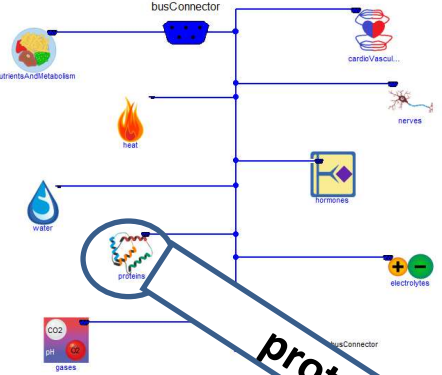

proteins

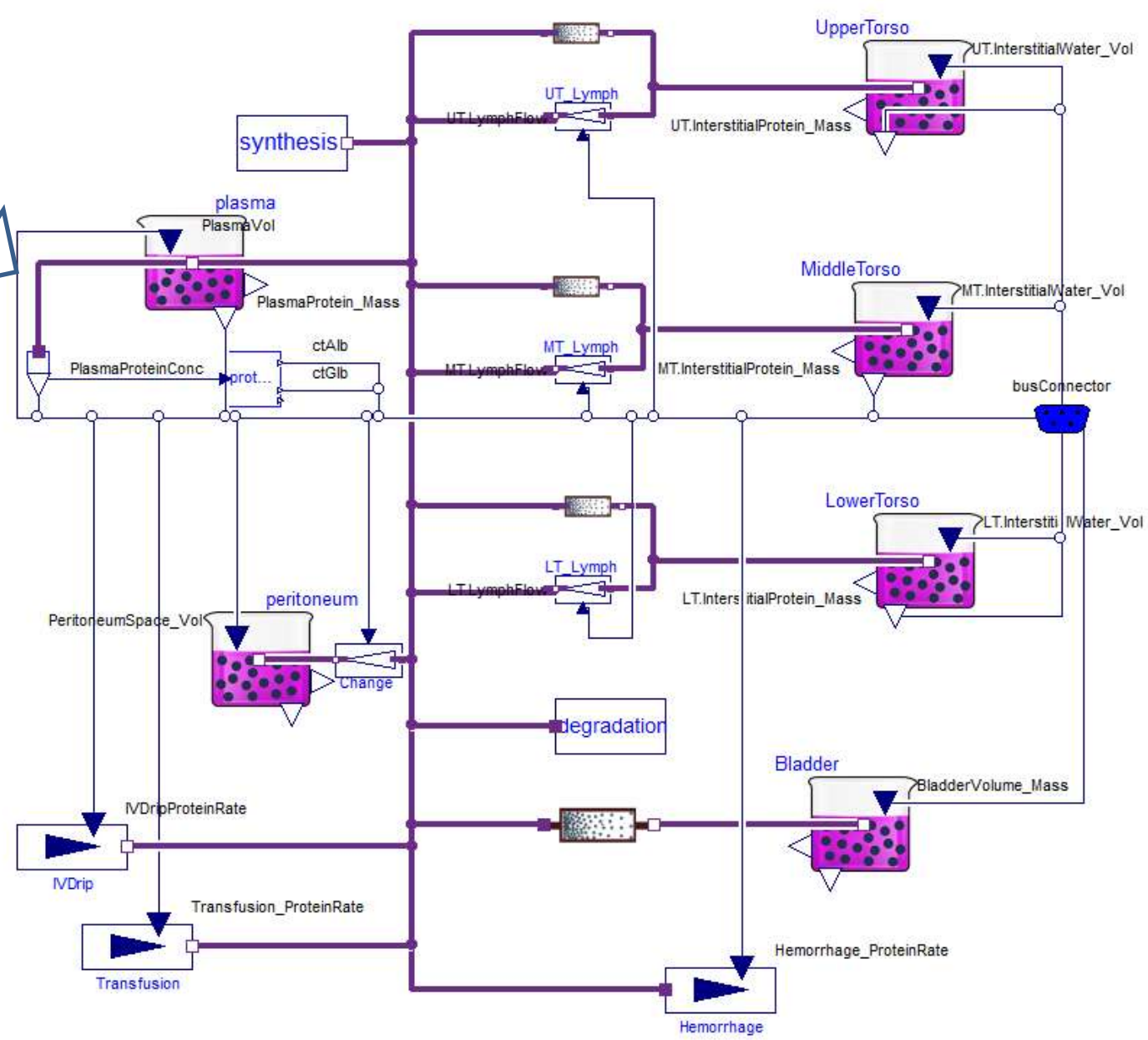

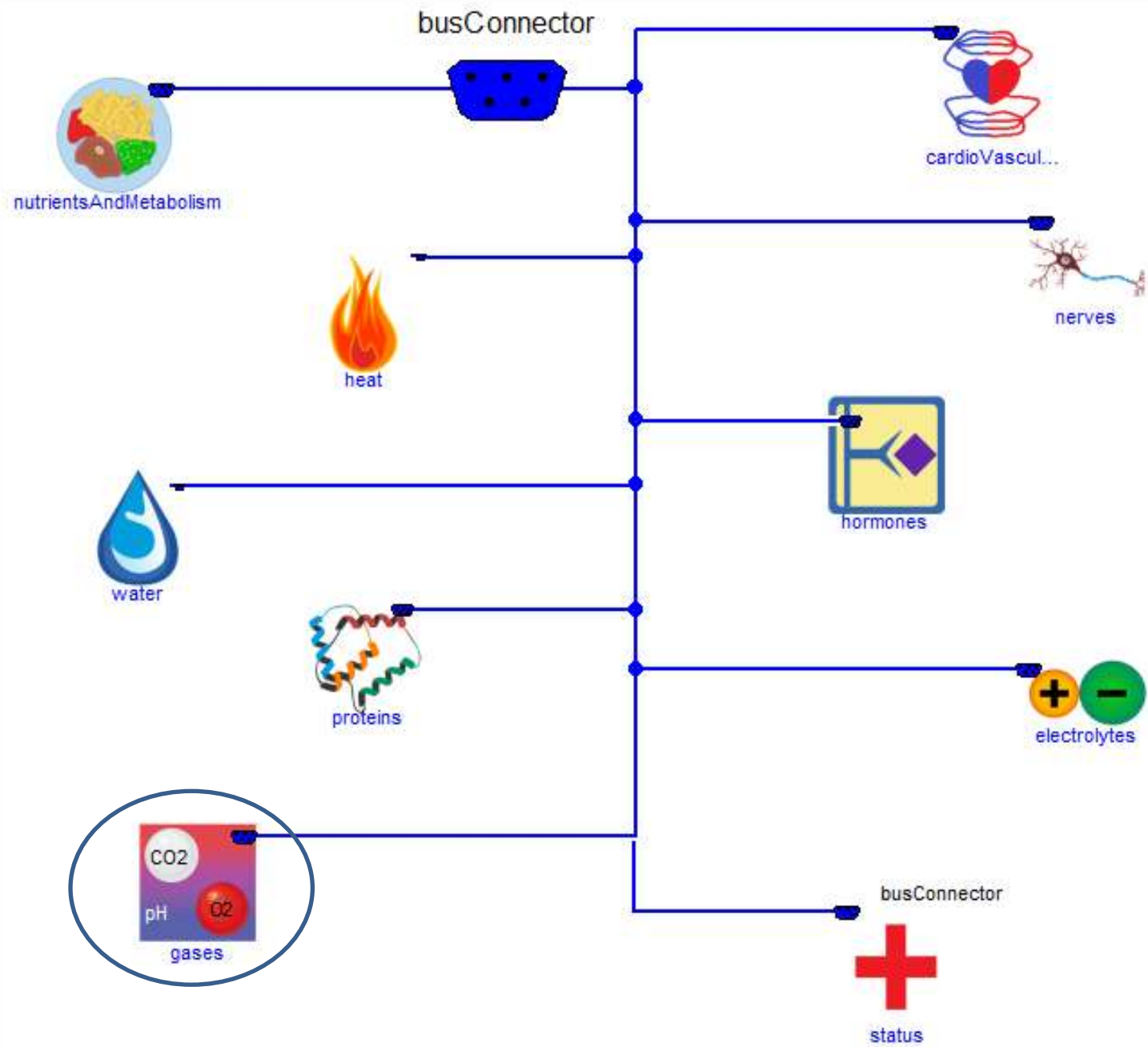

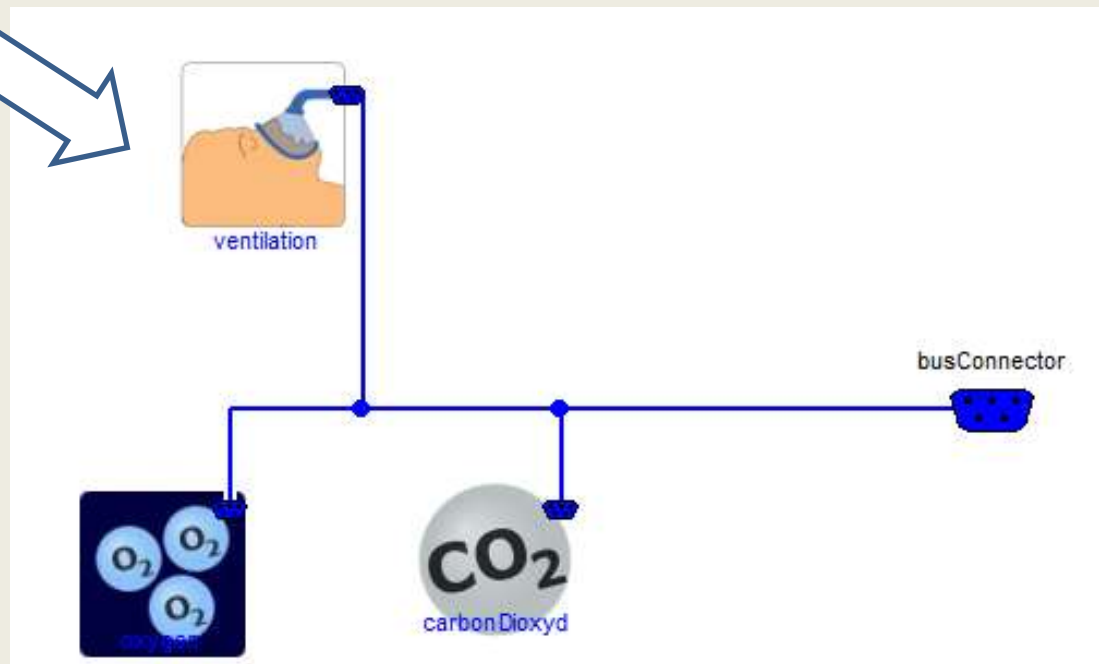
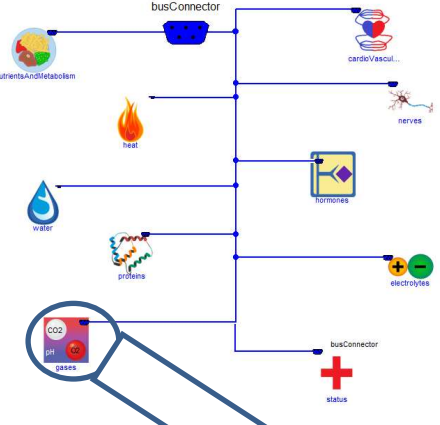

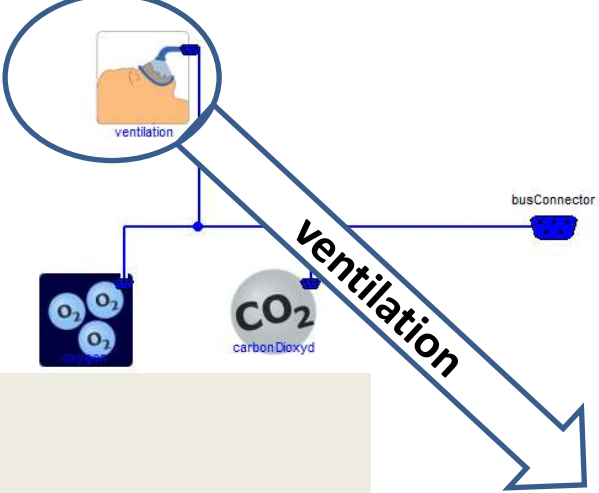

respiratoryNeuralDrive2_1

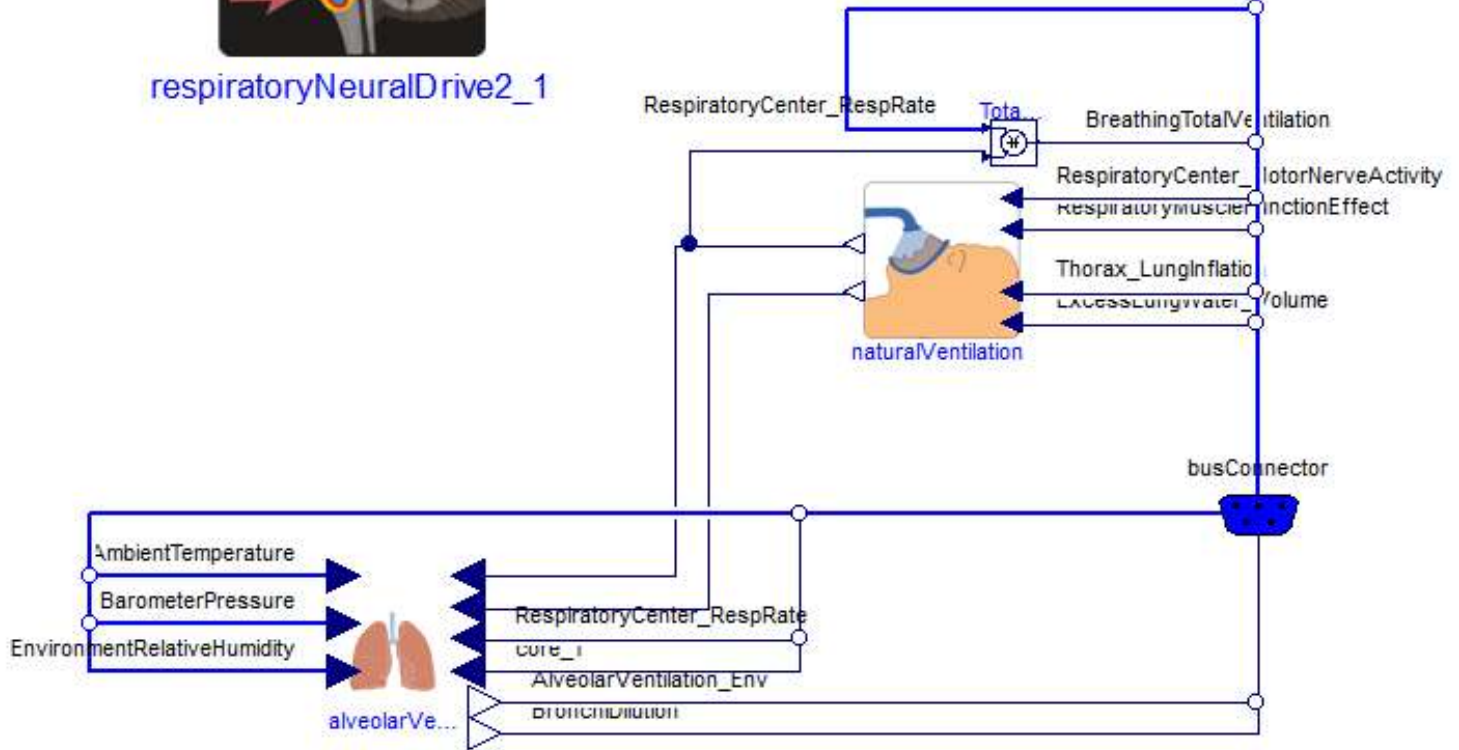

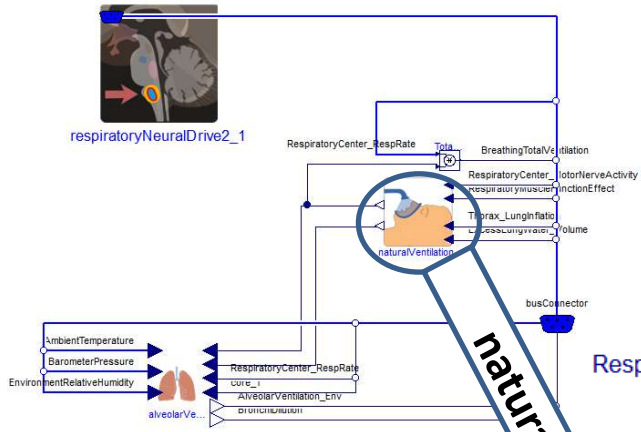

naturalVentilation

RespiratoryCenterOutput_MotorNerveActivity

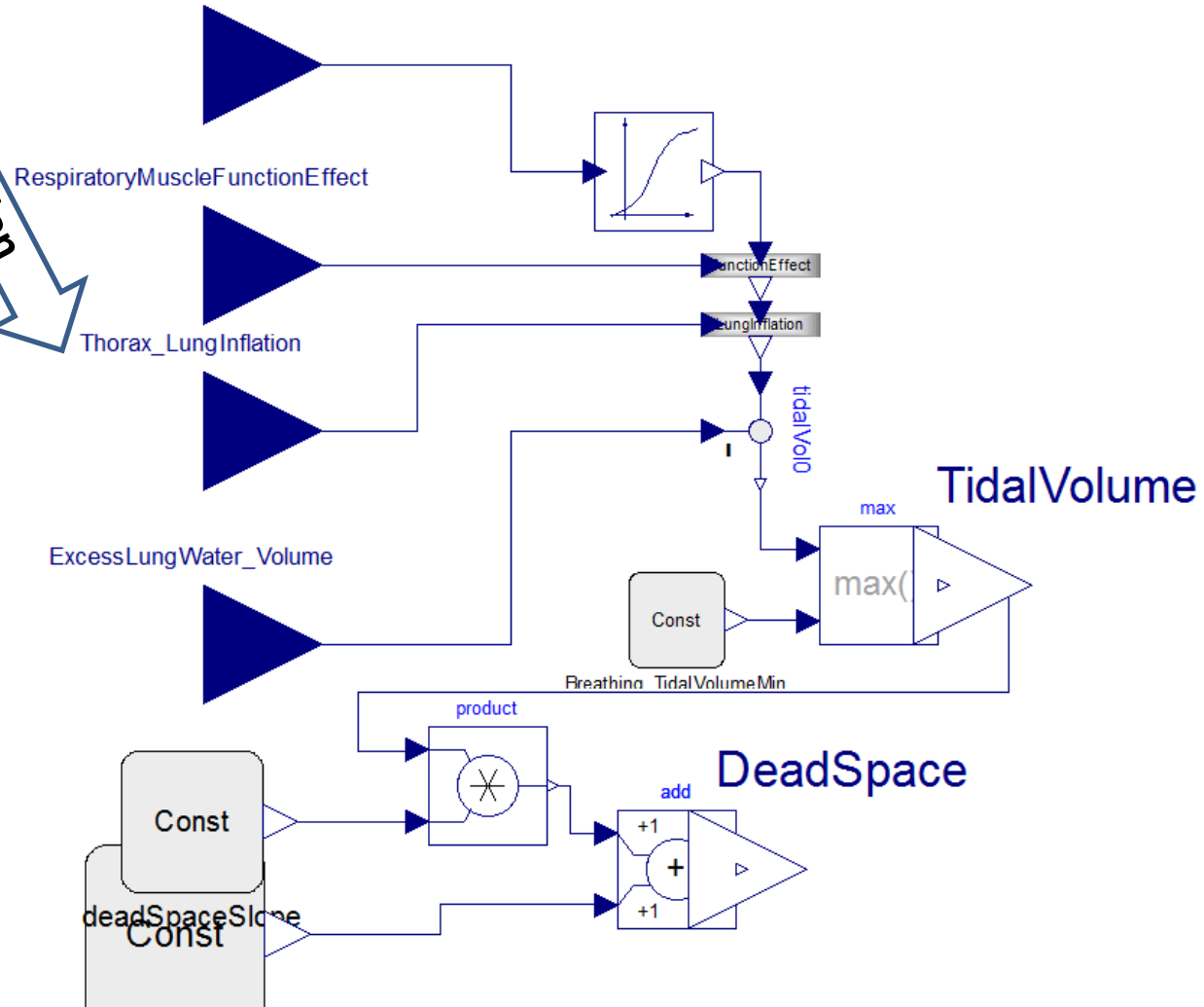

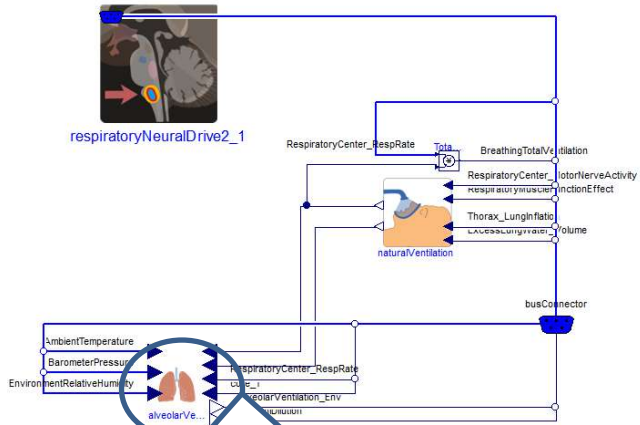

alveolarVentilation

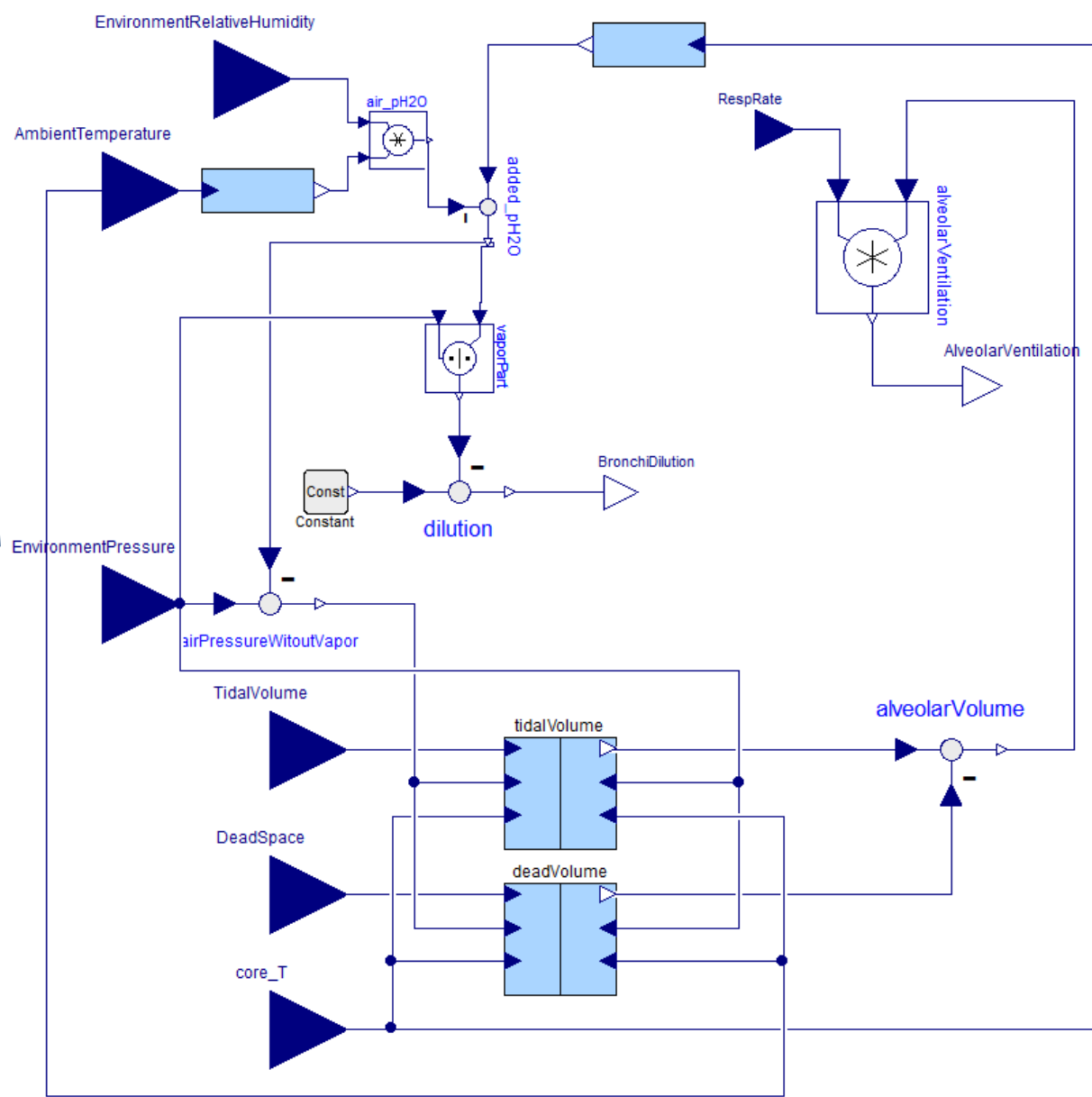

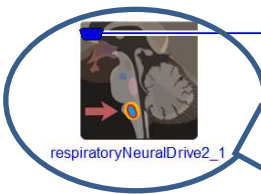

respiratoryNeuralDrive



busConnector

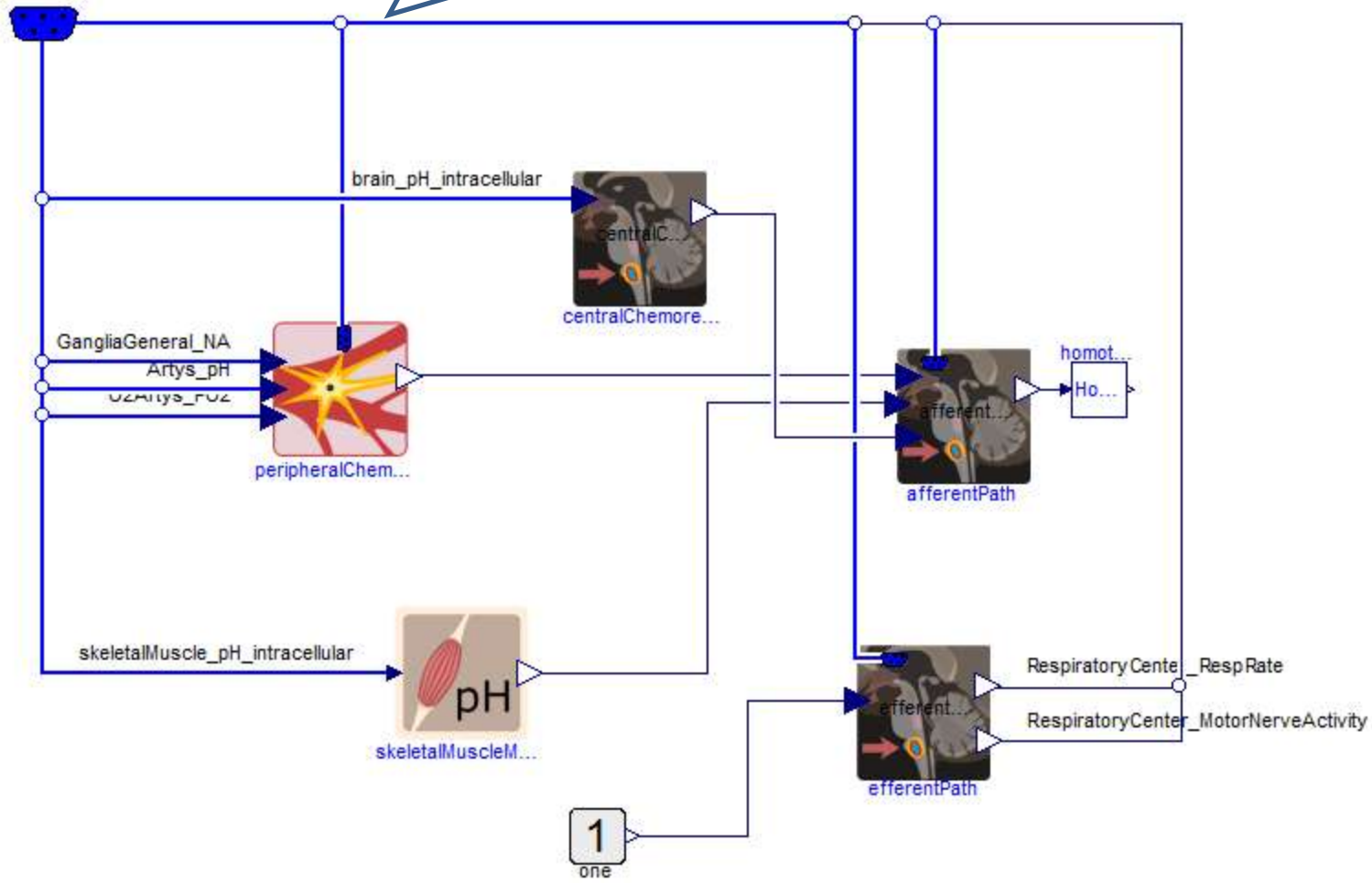

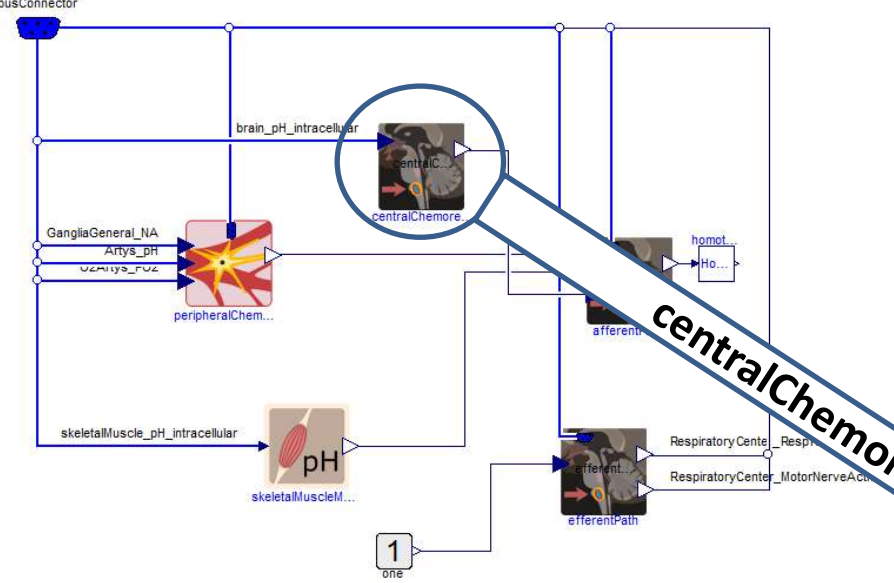

centralChemoreceptor

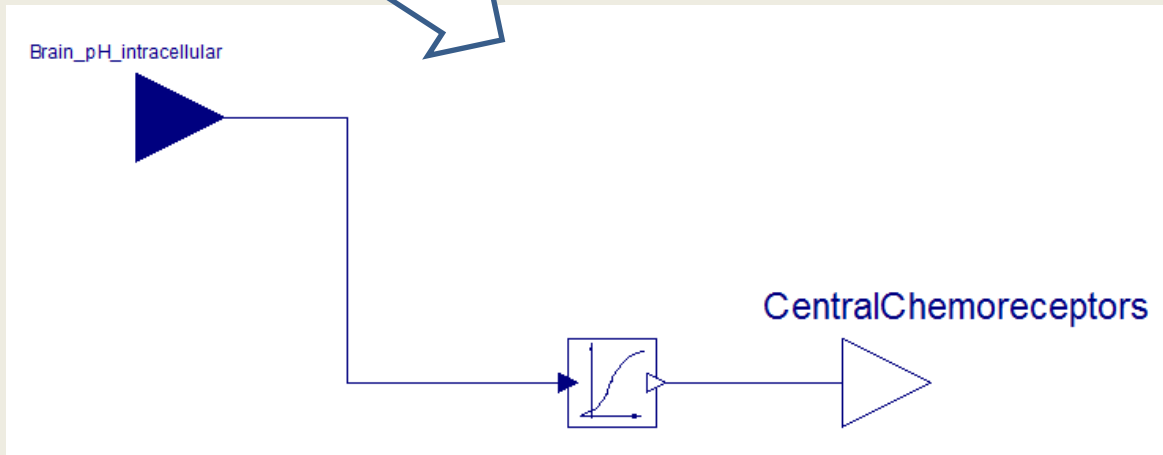

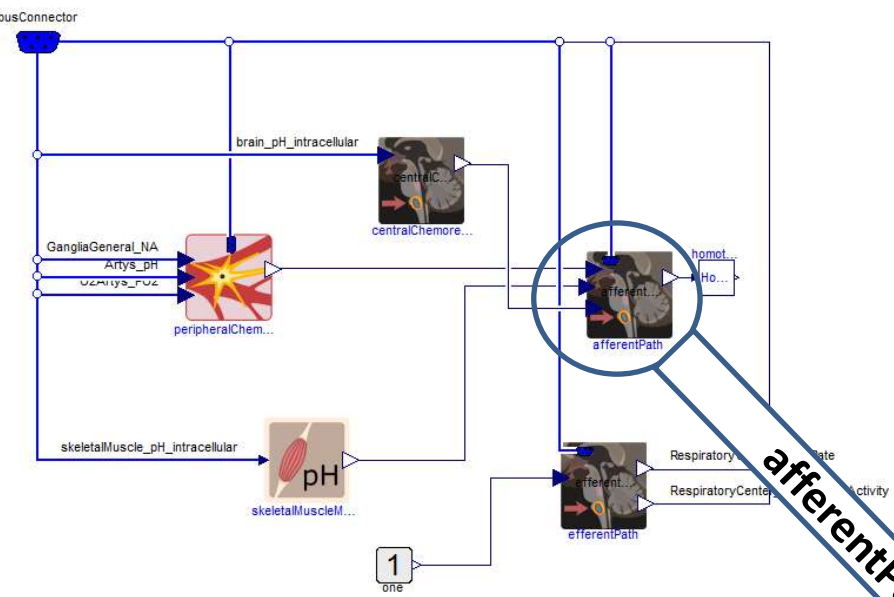

afferentPath

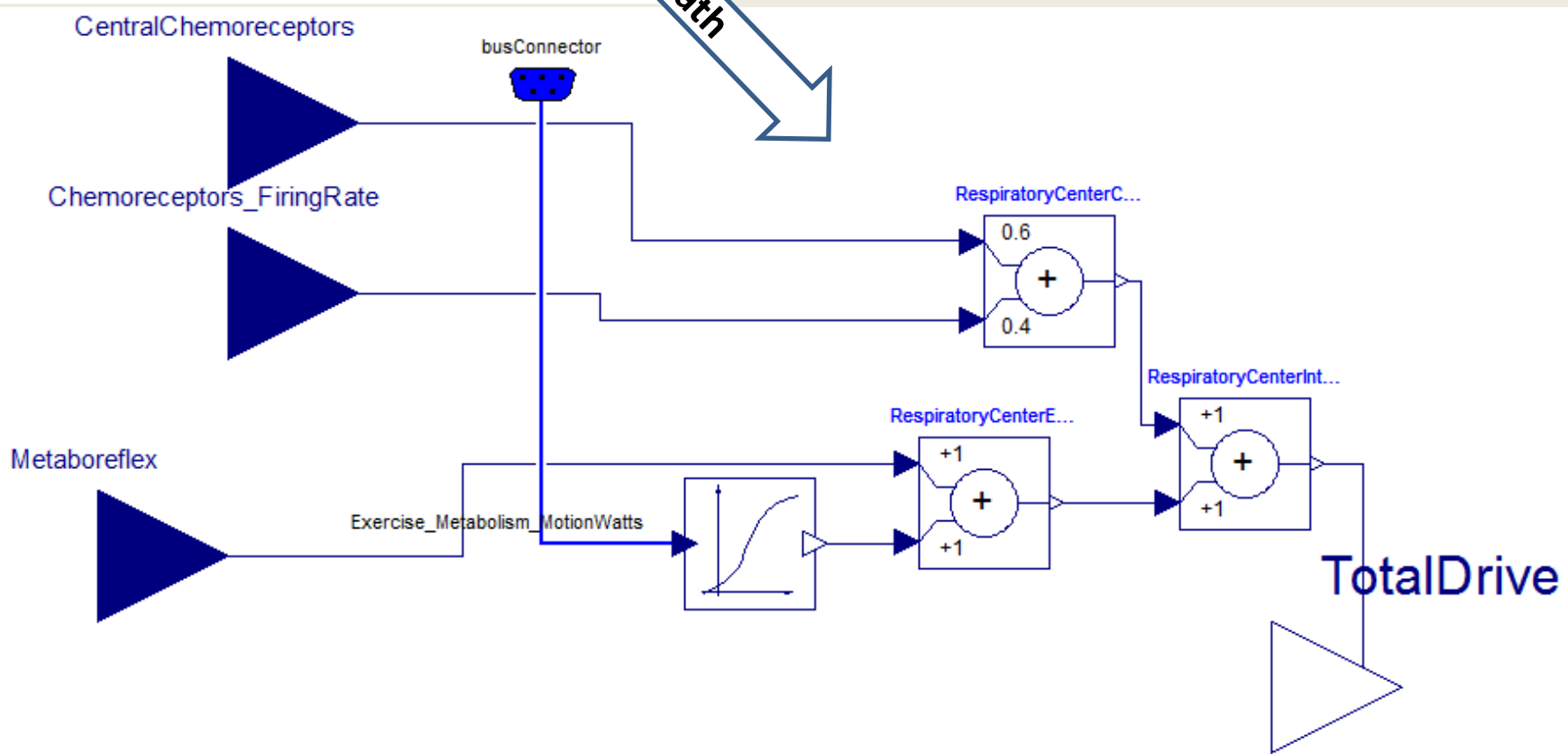

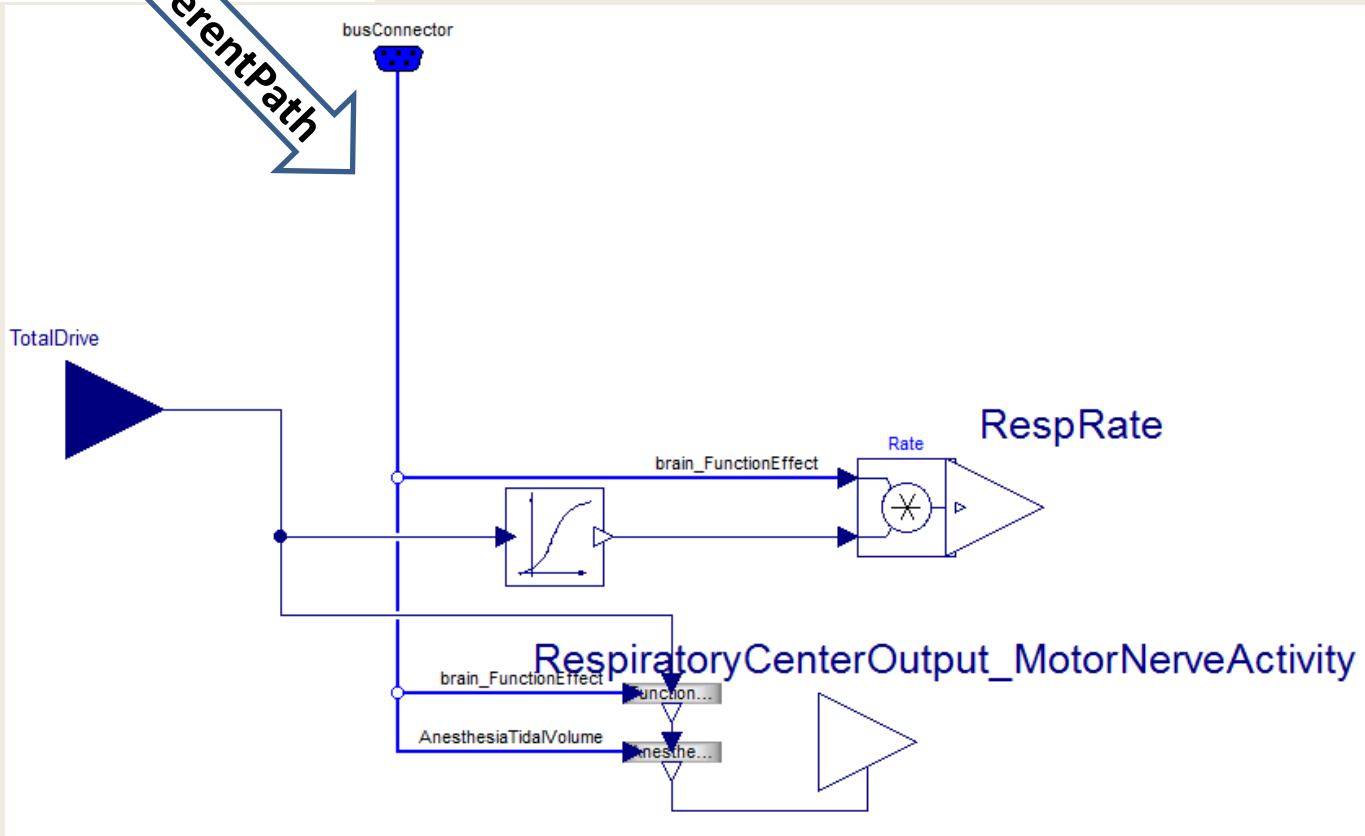
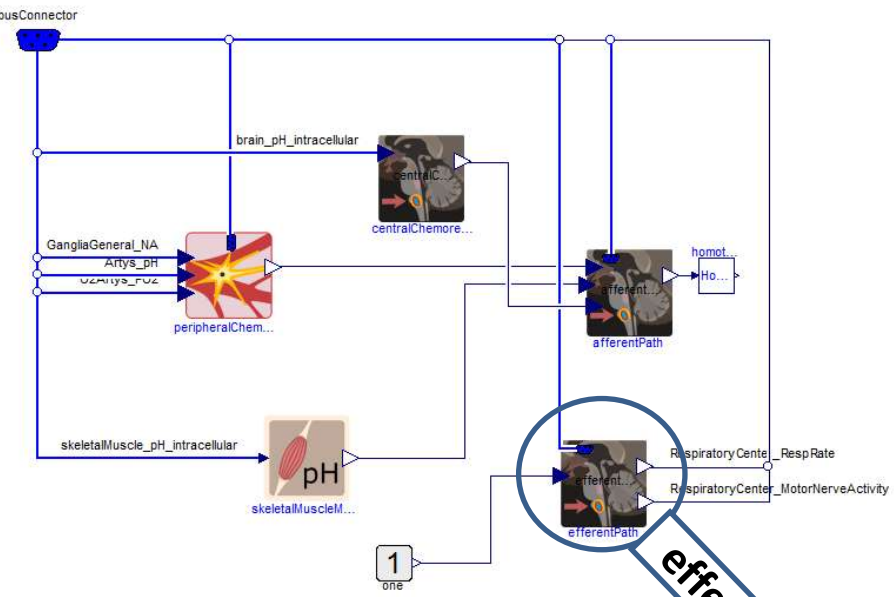

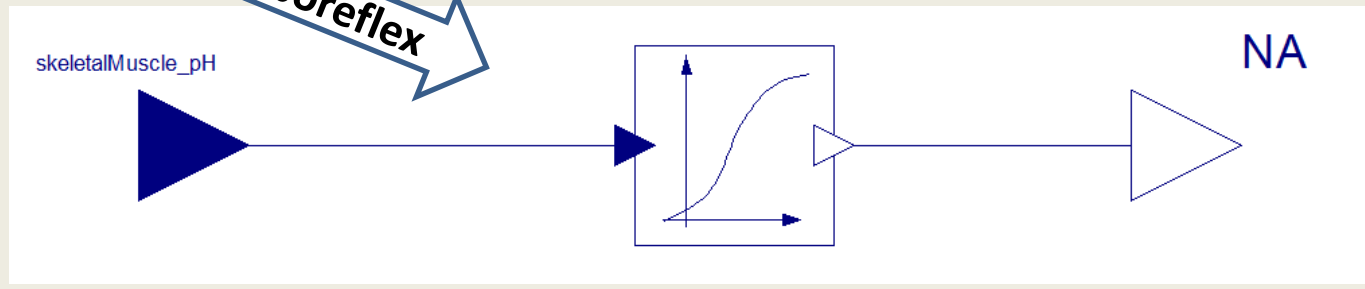
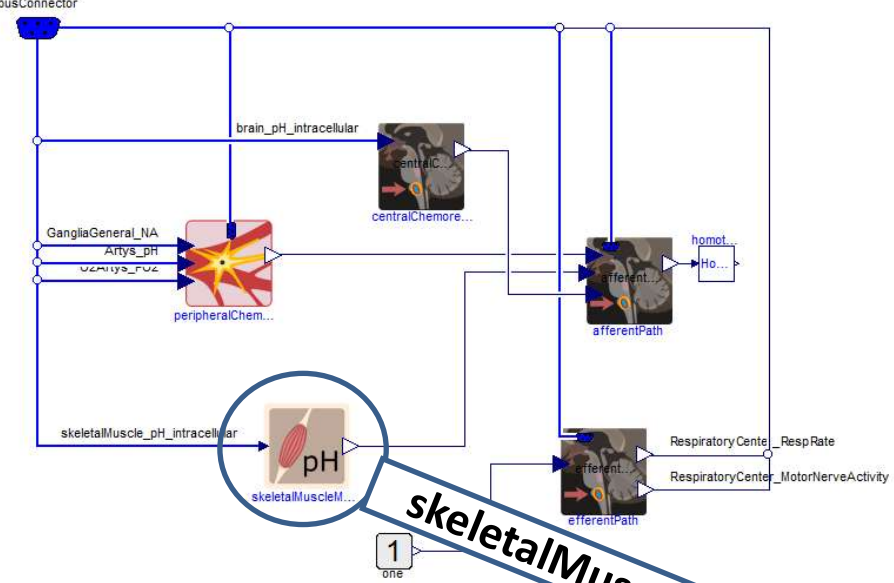

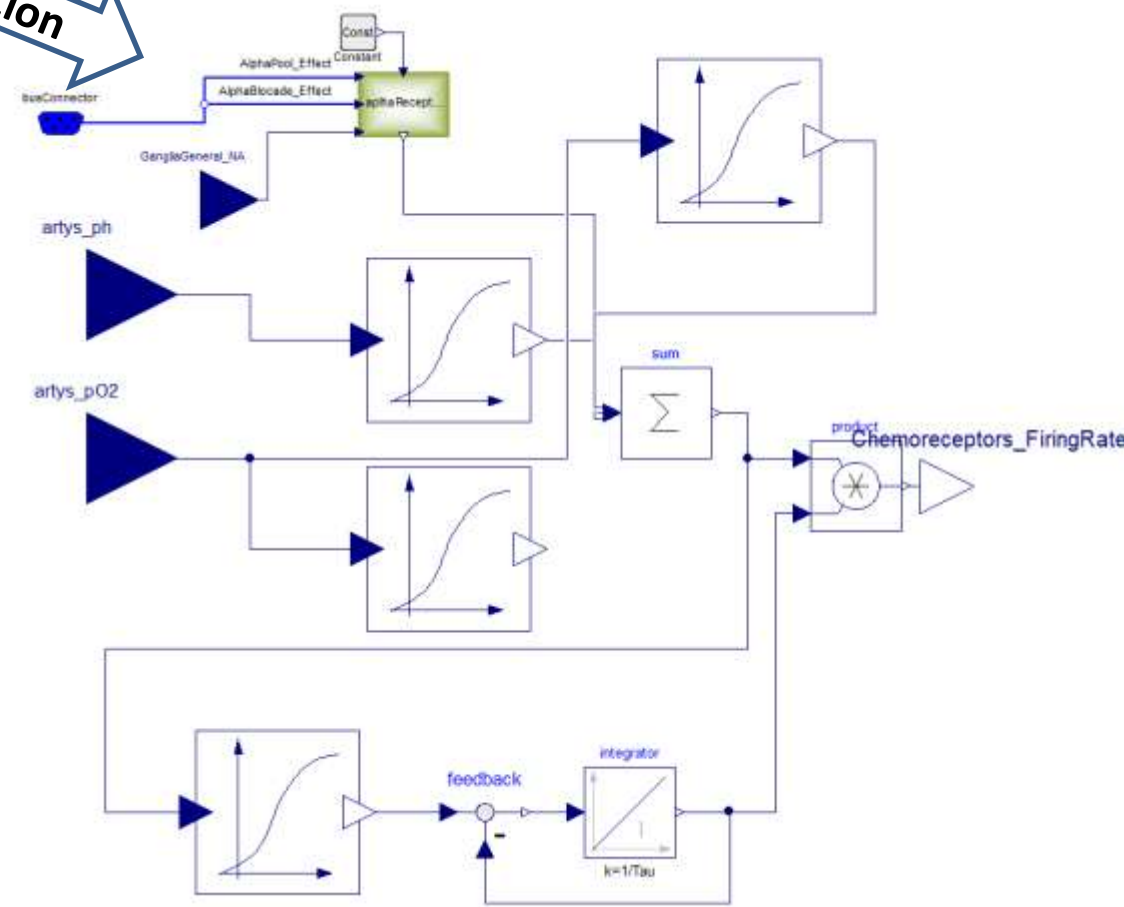
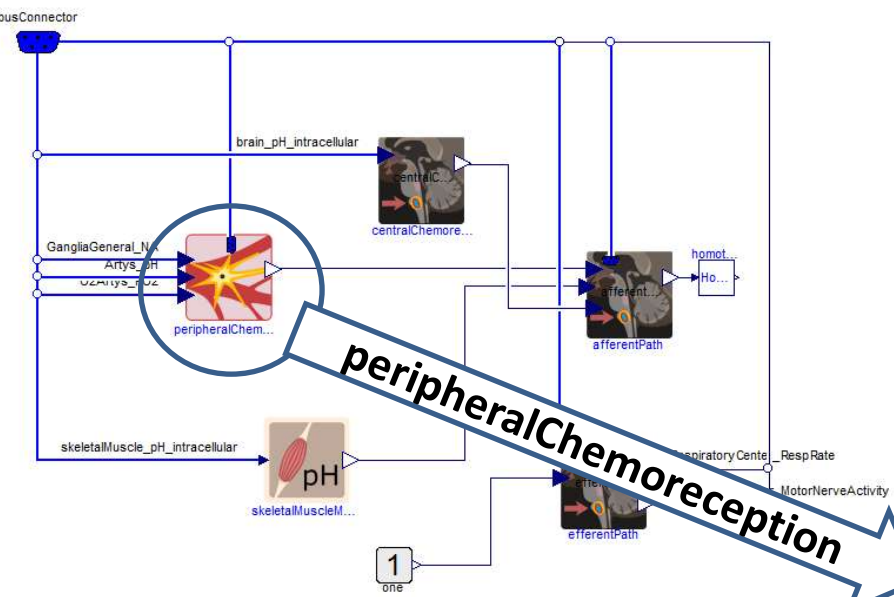

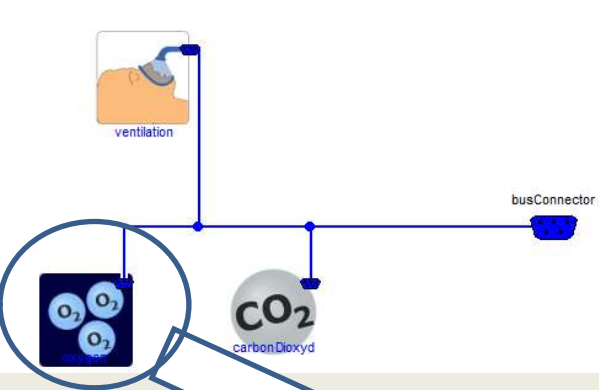

oxygen

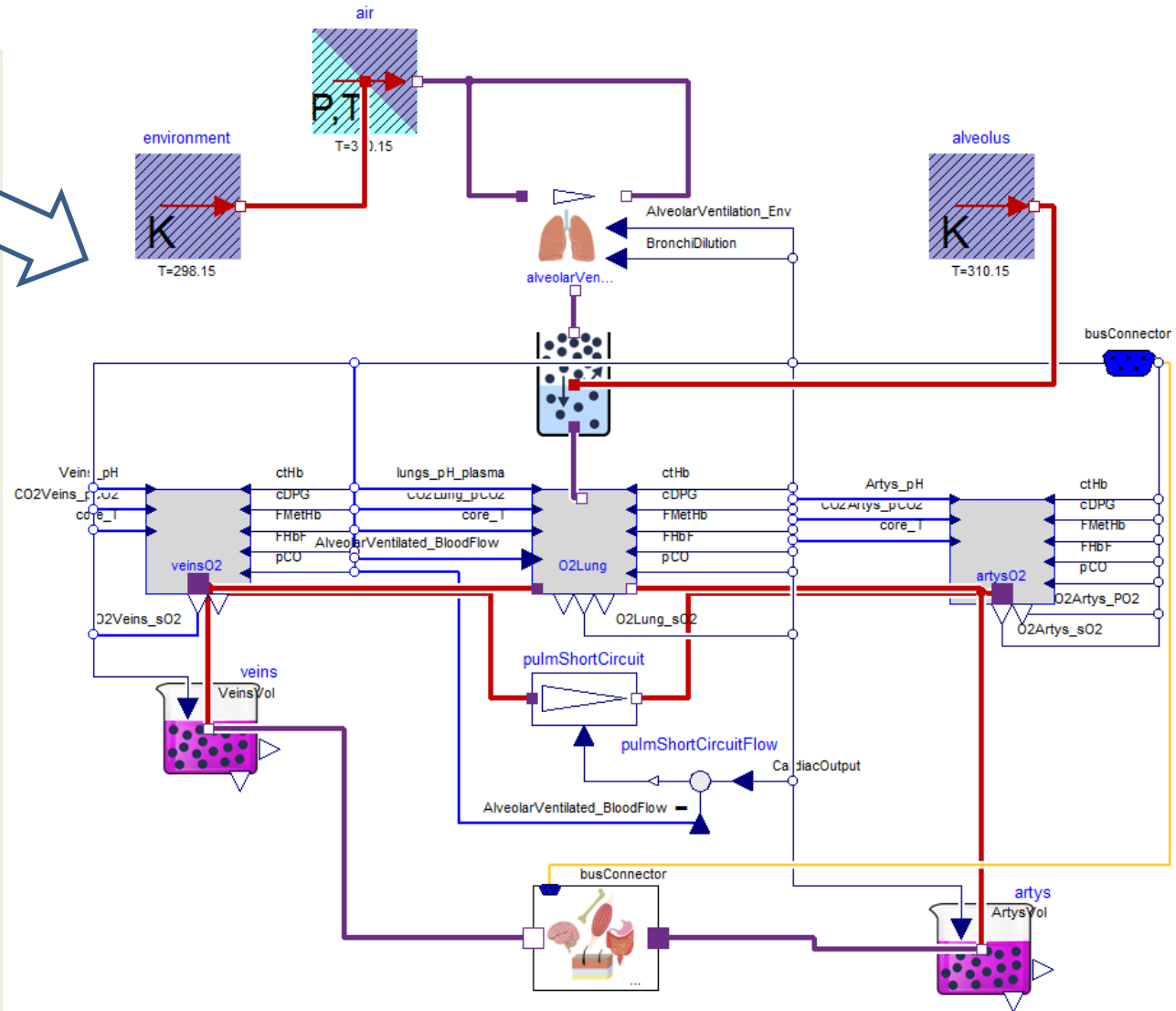

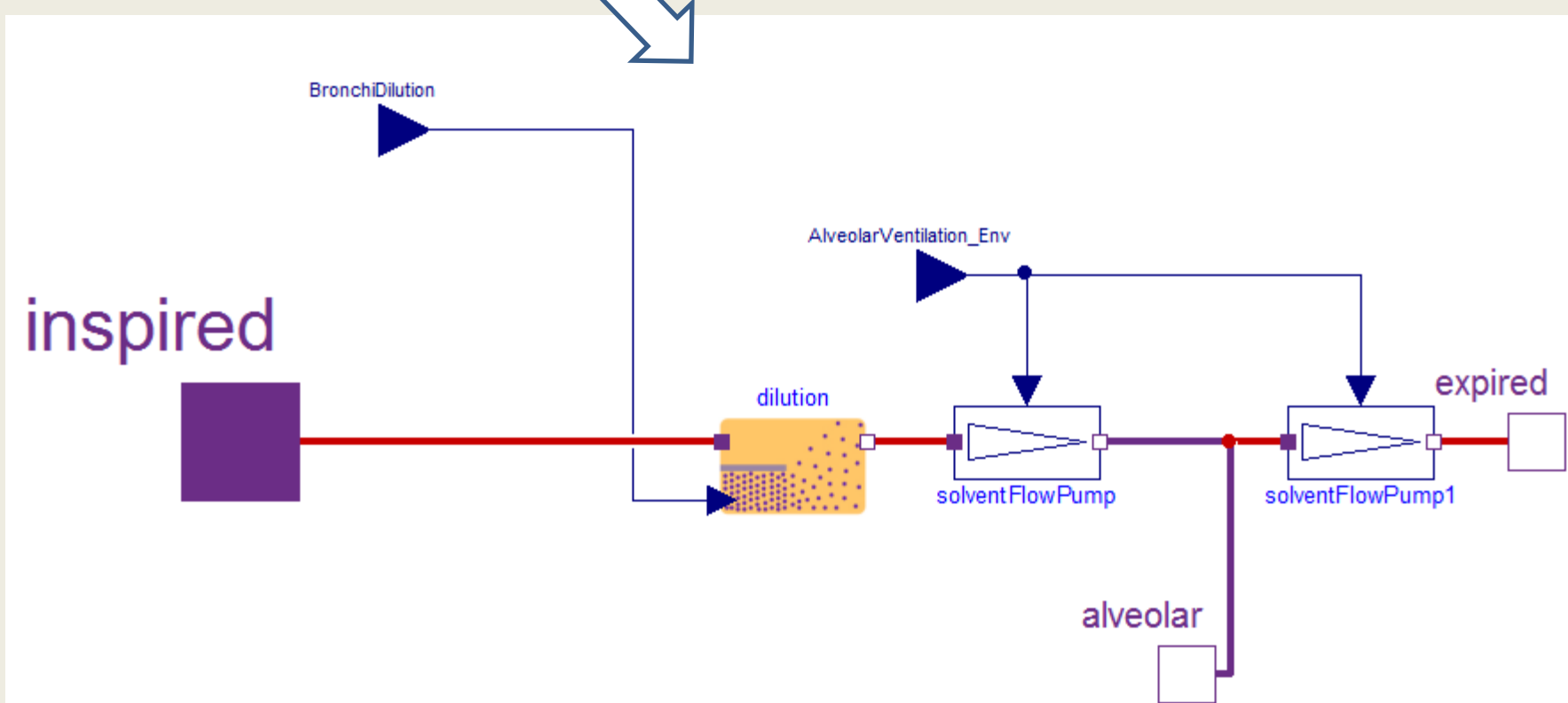
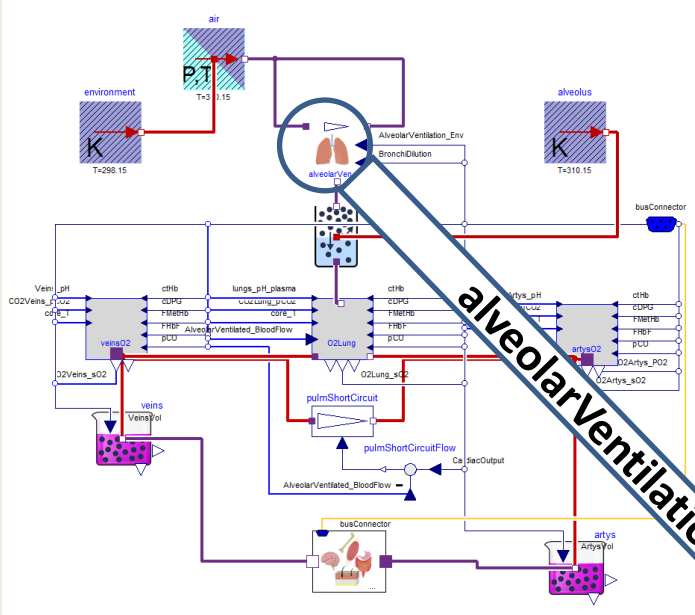

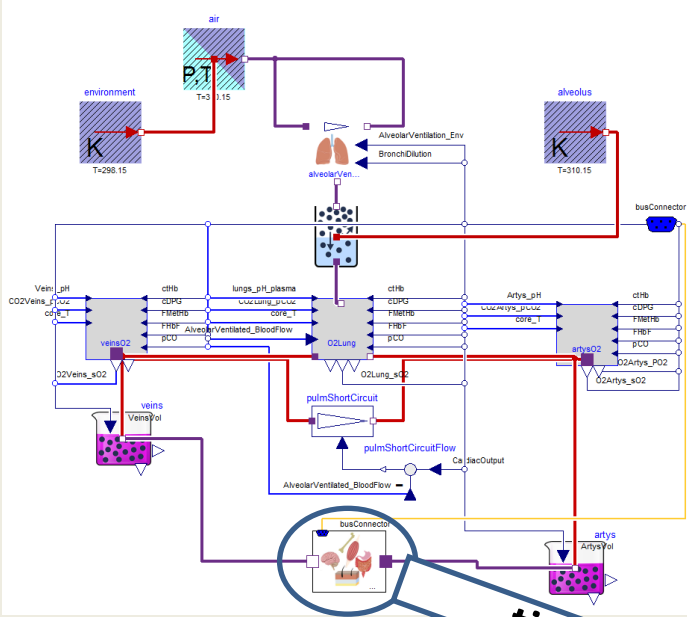

tissuesO2

busConnector

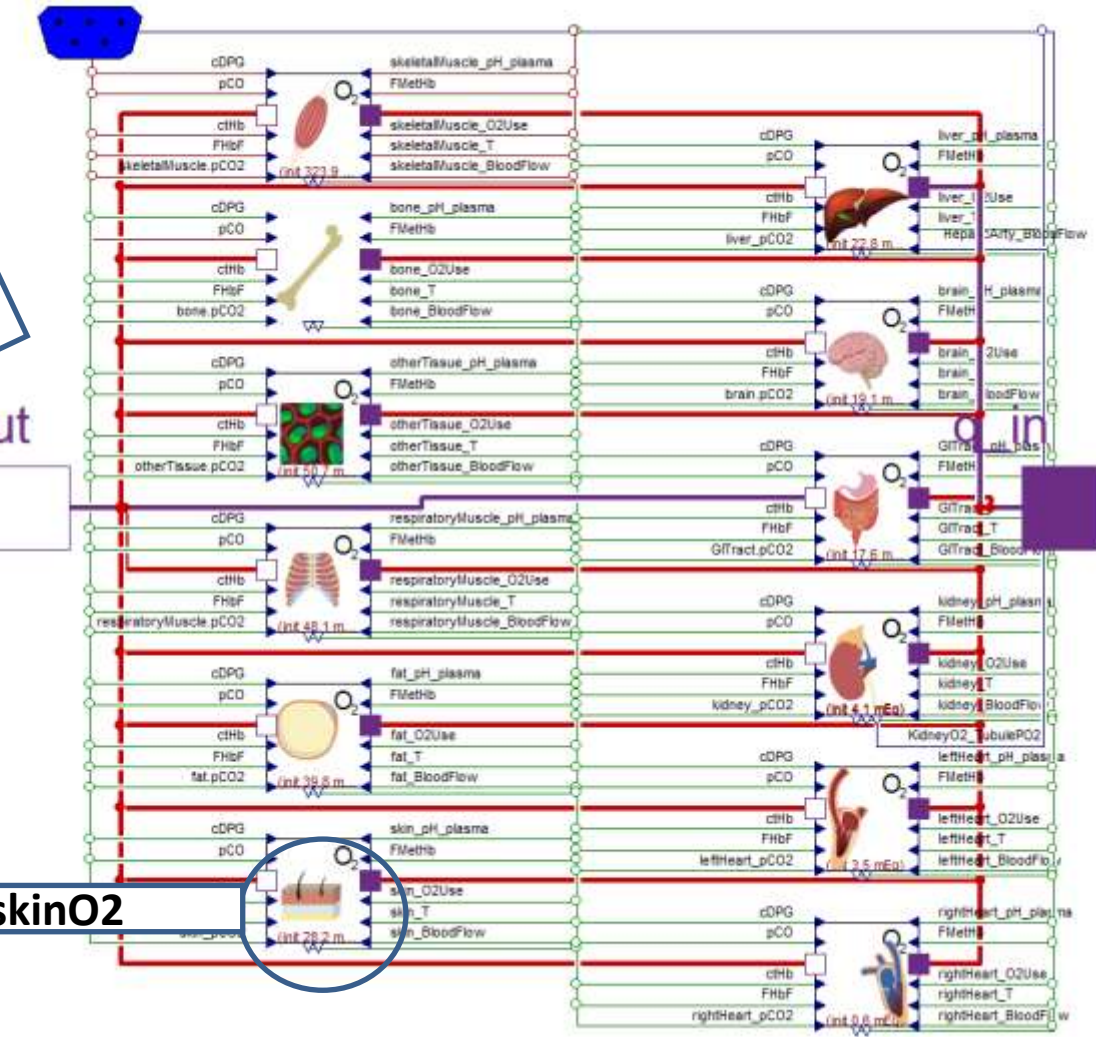

q_out

q_in

The instances of the same class with different parameters

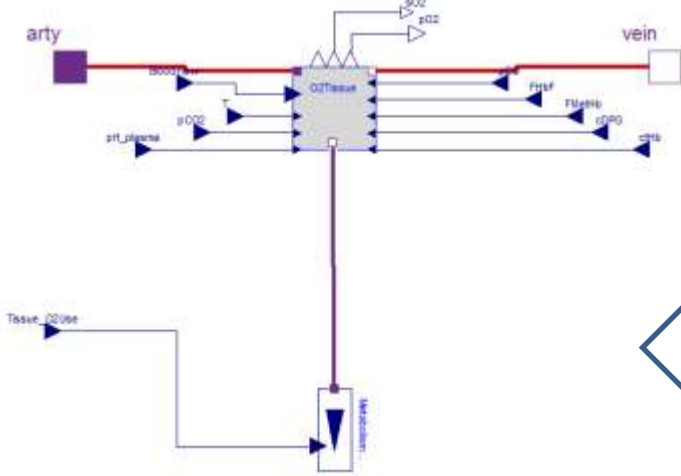

skinO2

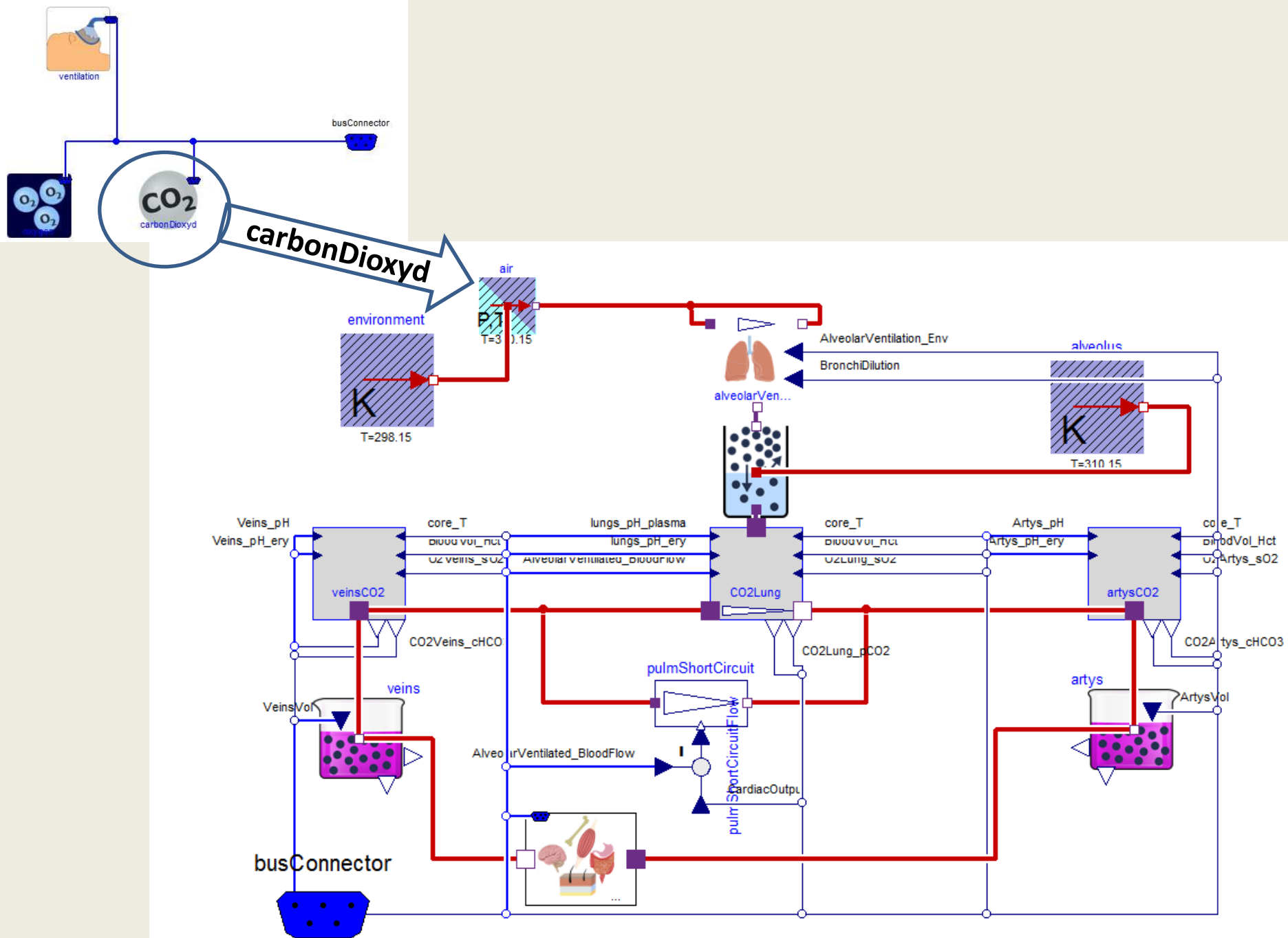

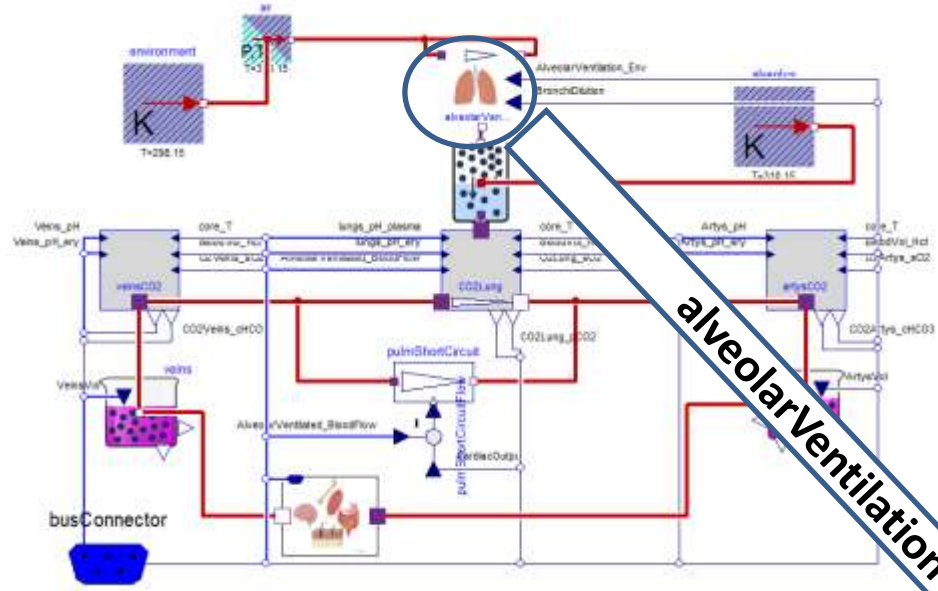

alveolarVentilation

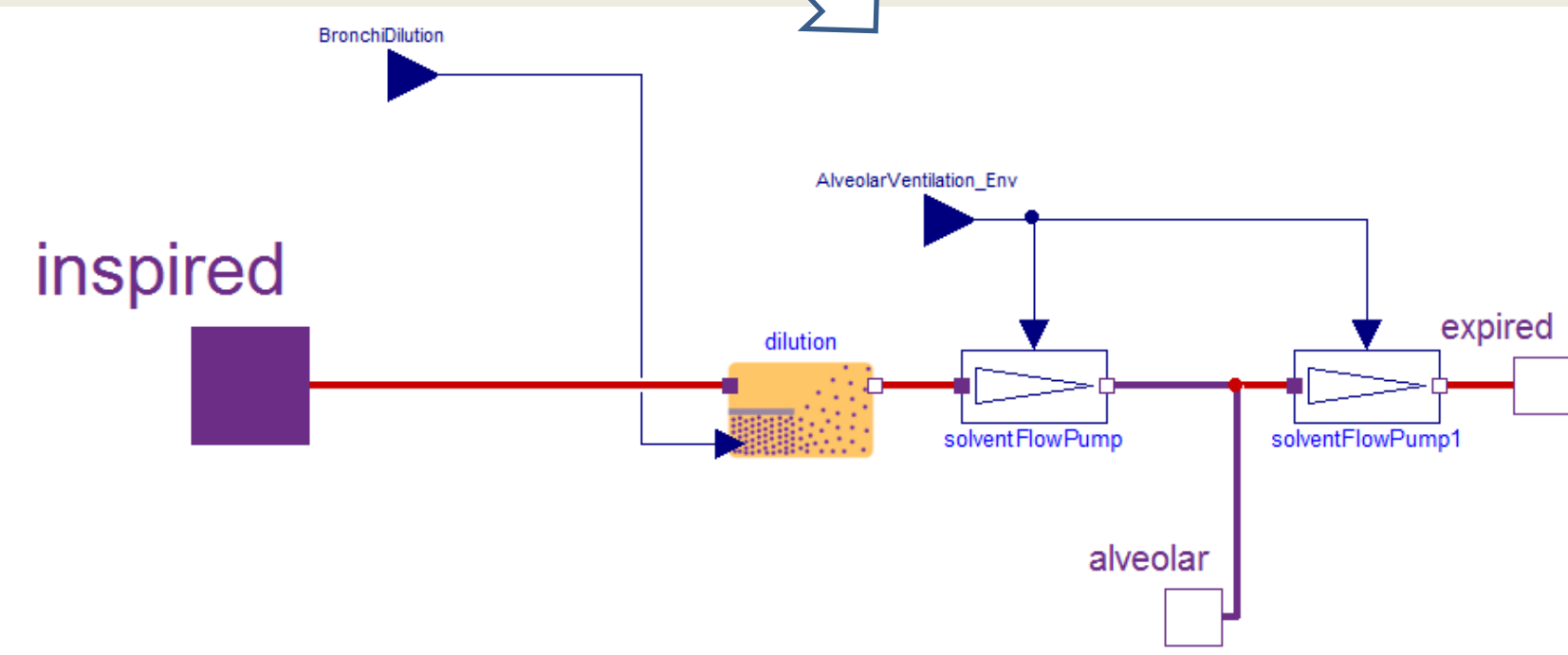

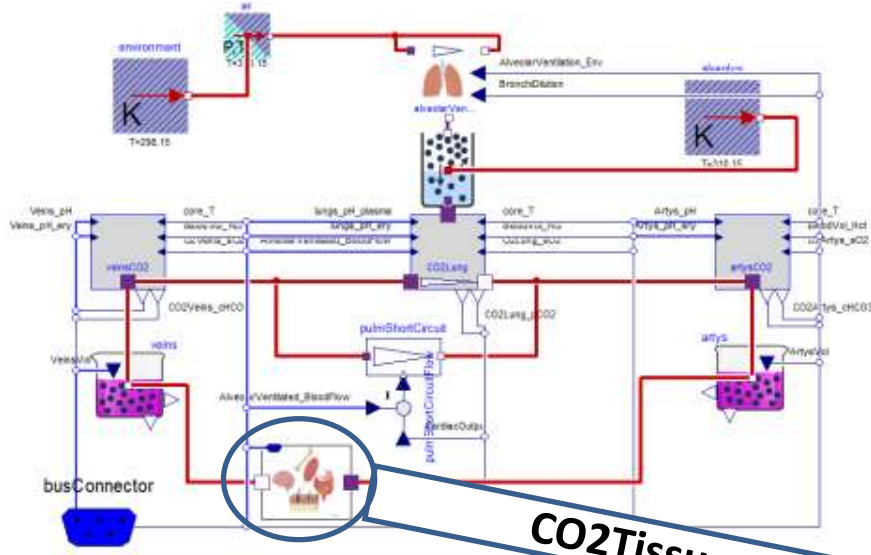

CO2Tissues

busConnector

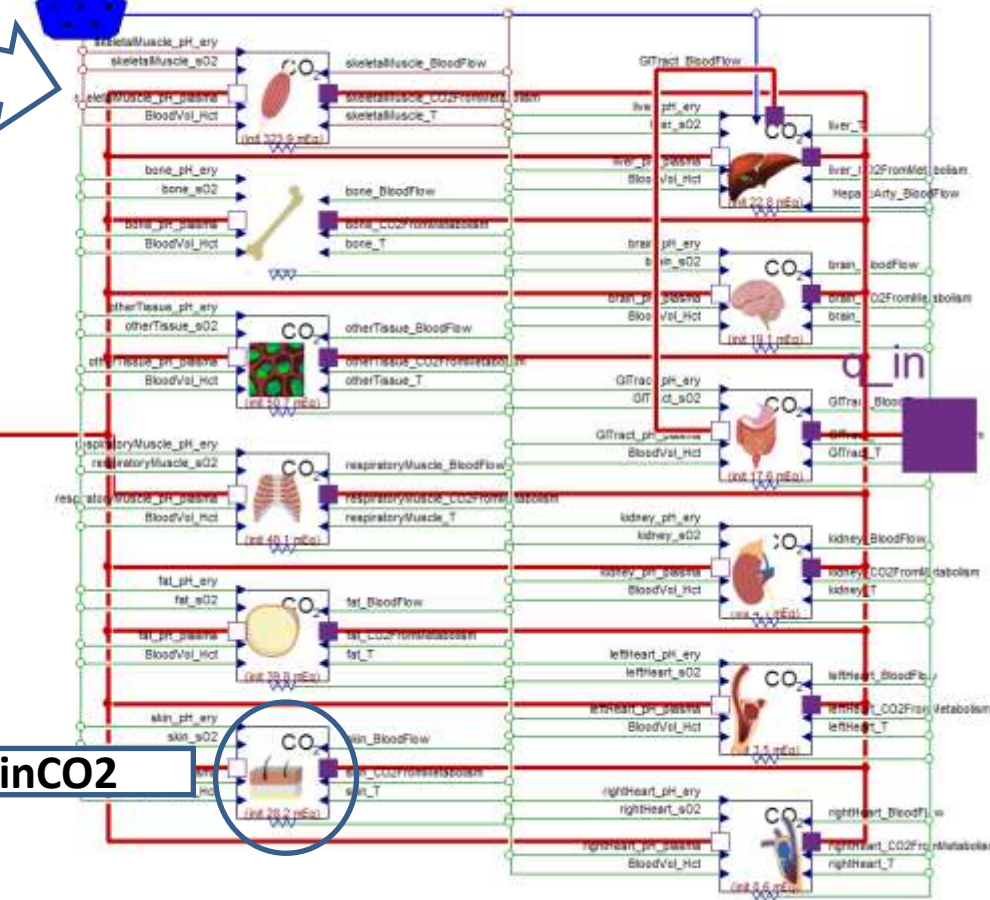

skinCO2

The instances of the same class with different parameters

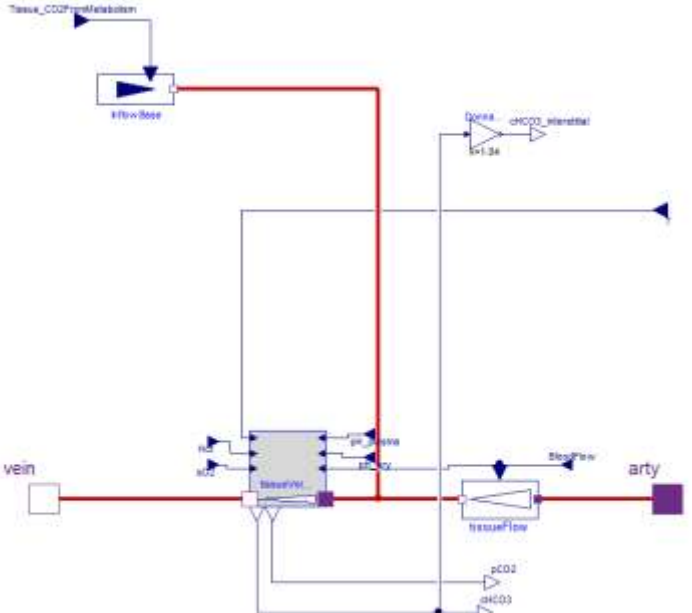

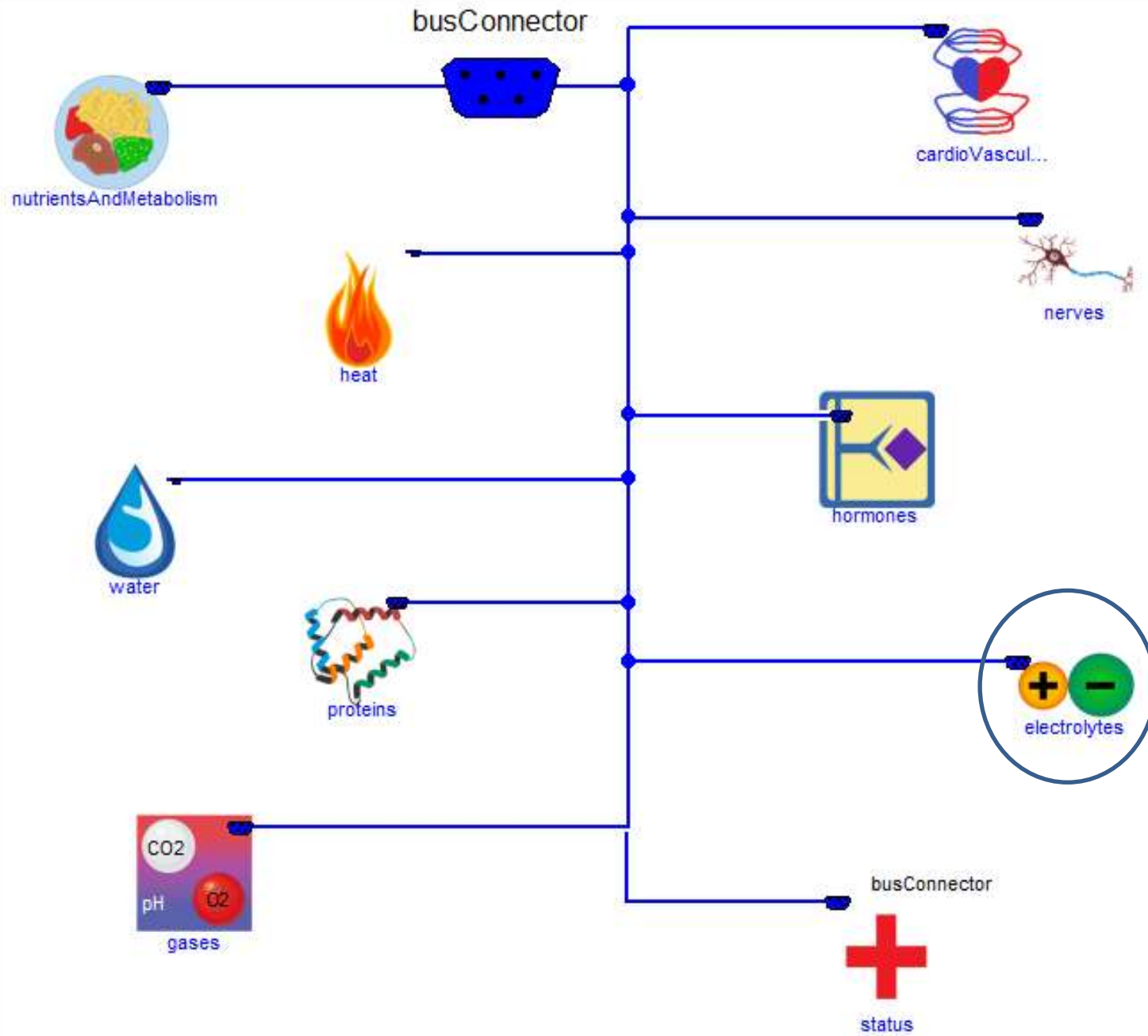

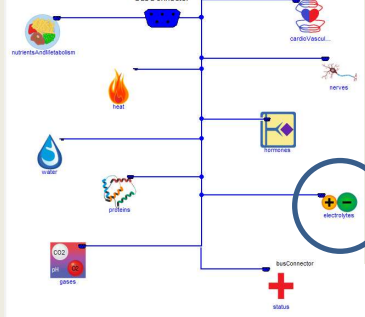

electrolytes

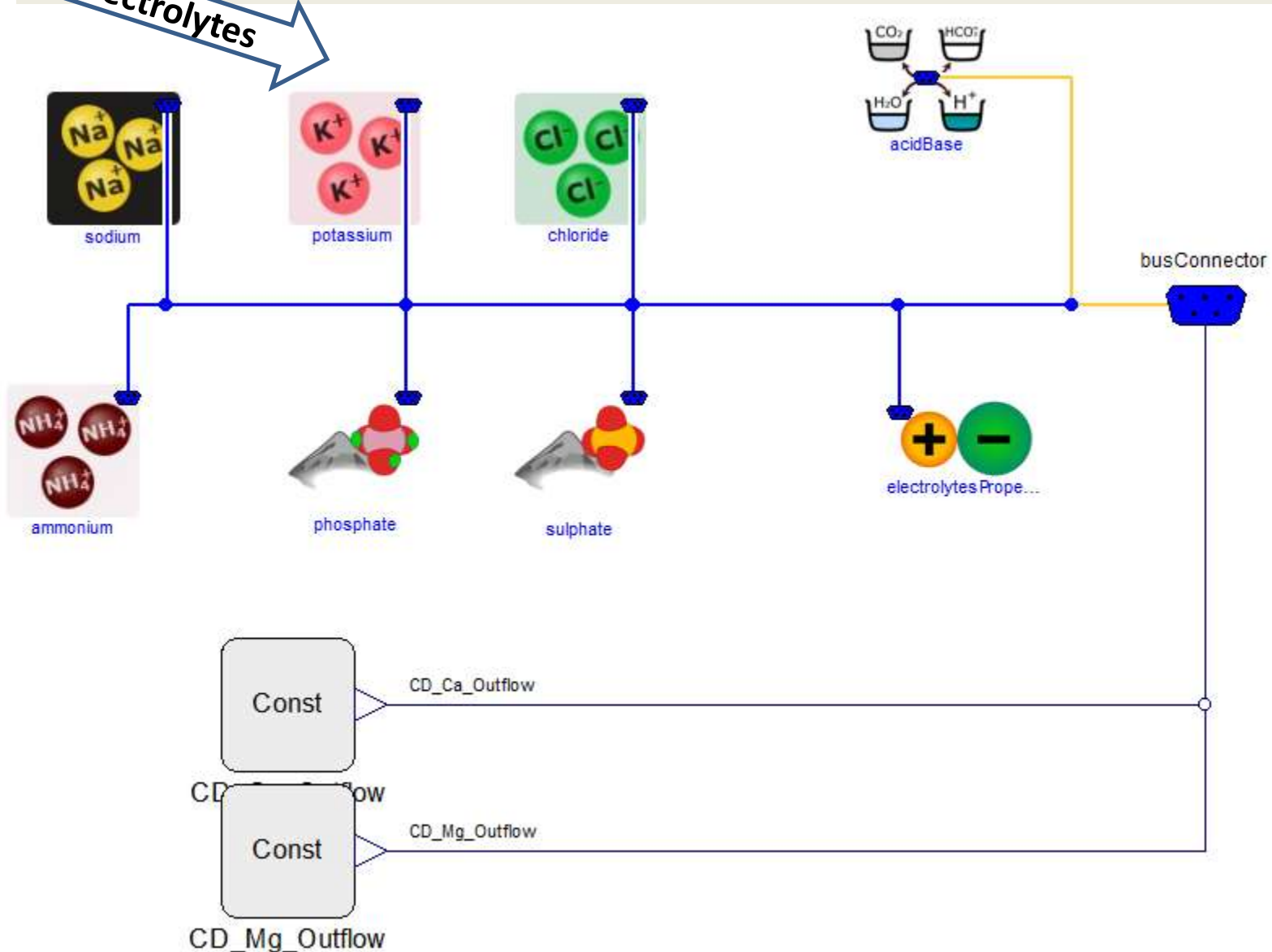

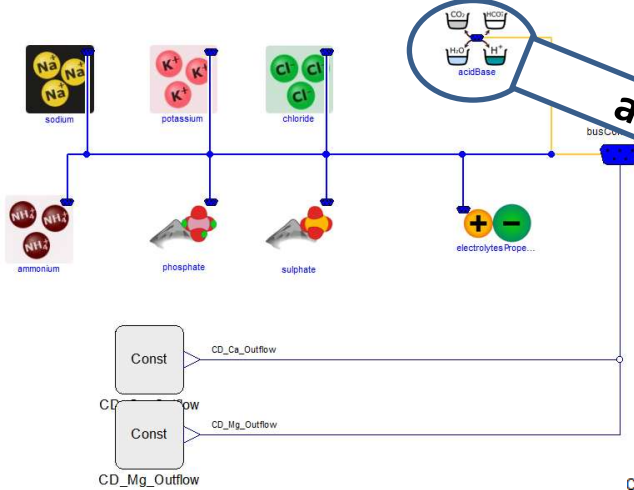

acidBase

busConnector

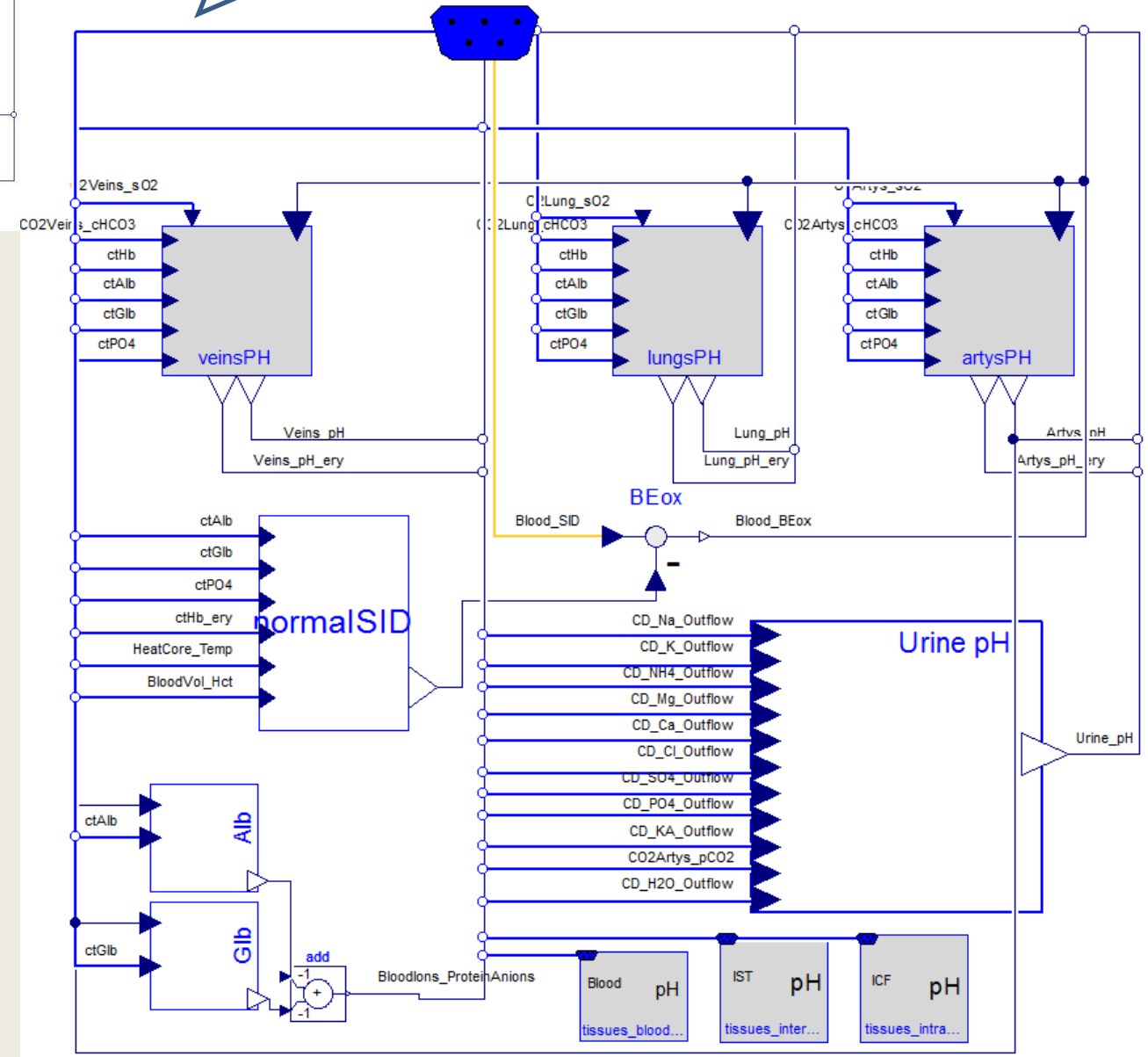

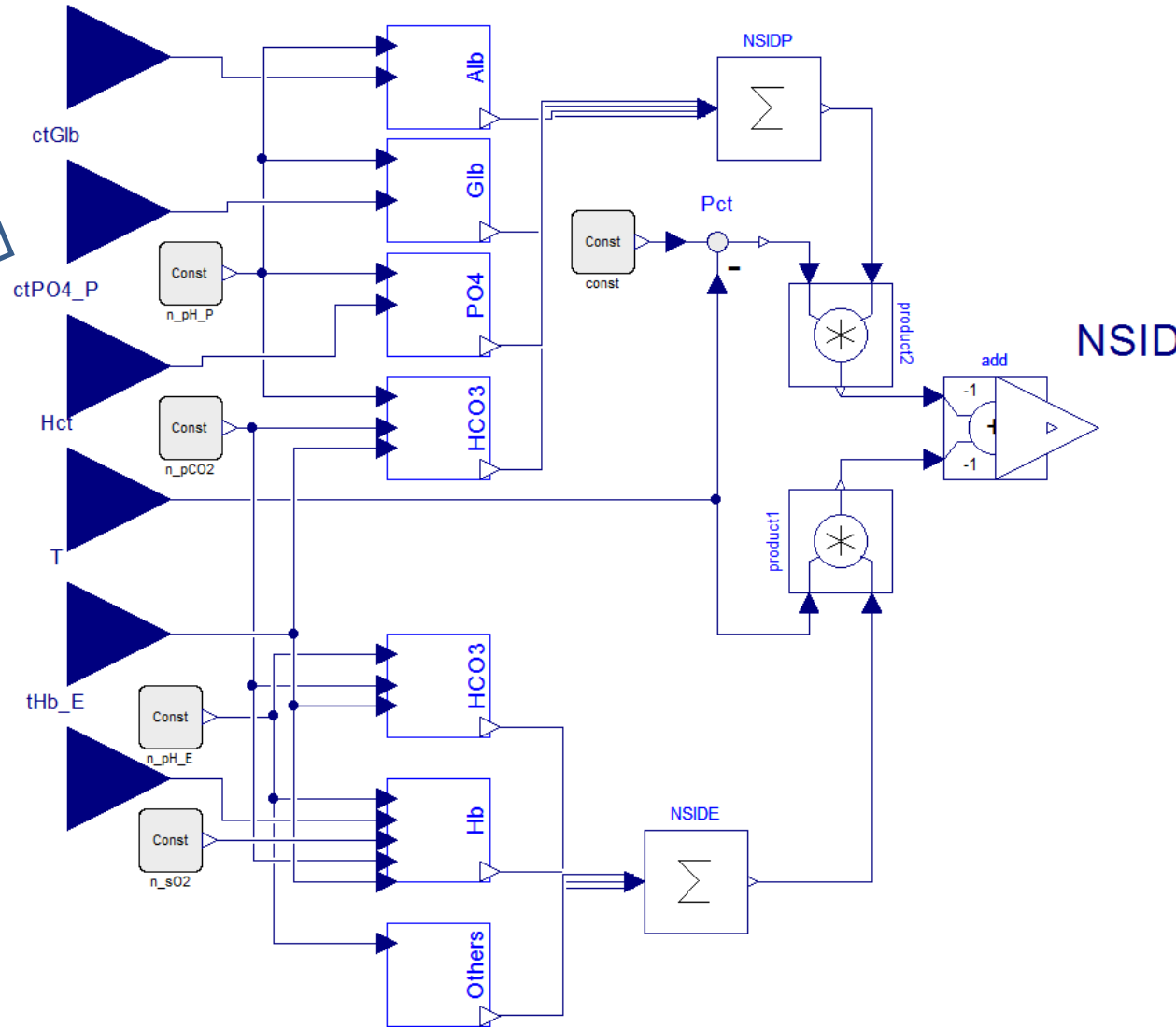
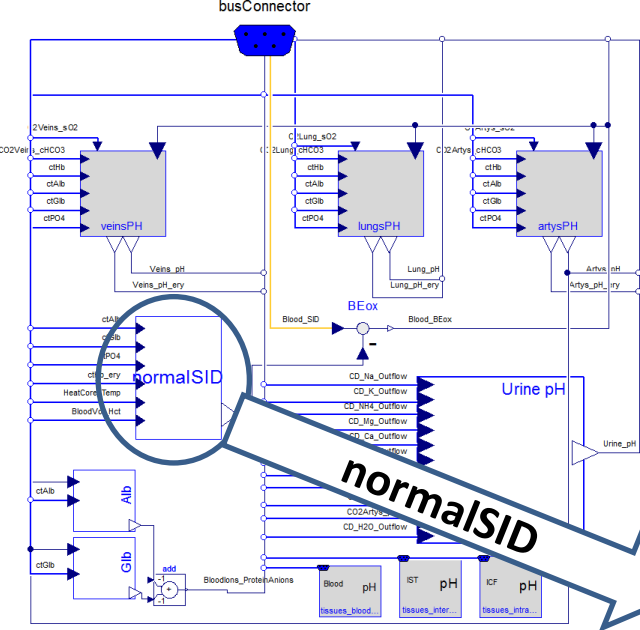

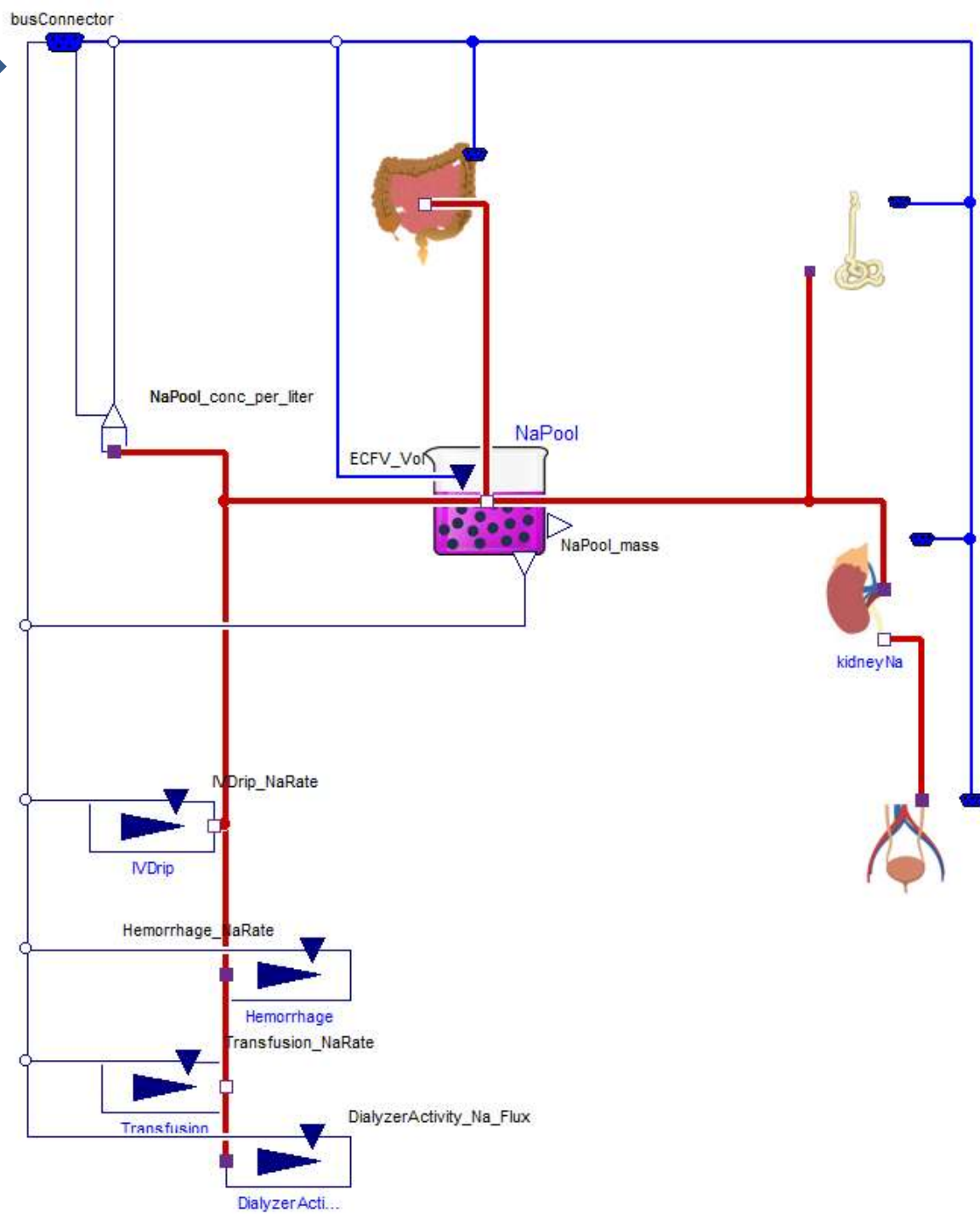
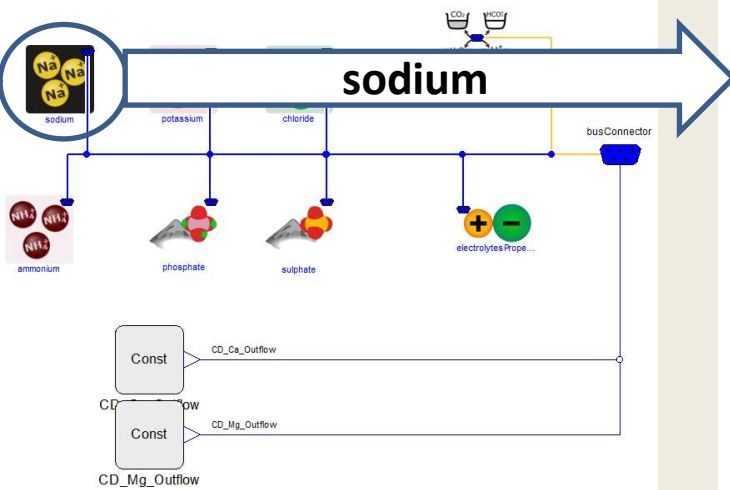

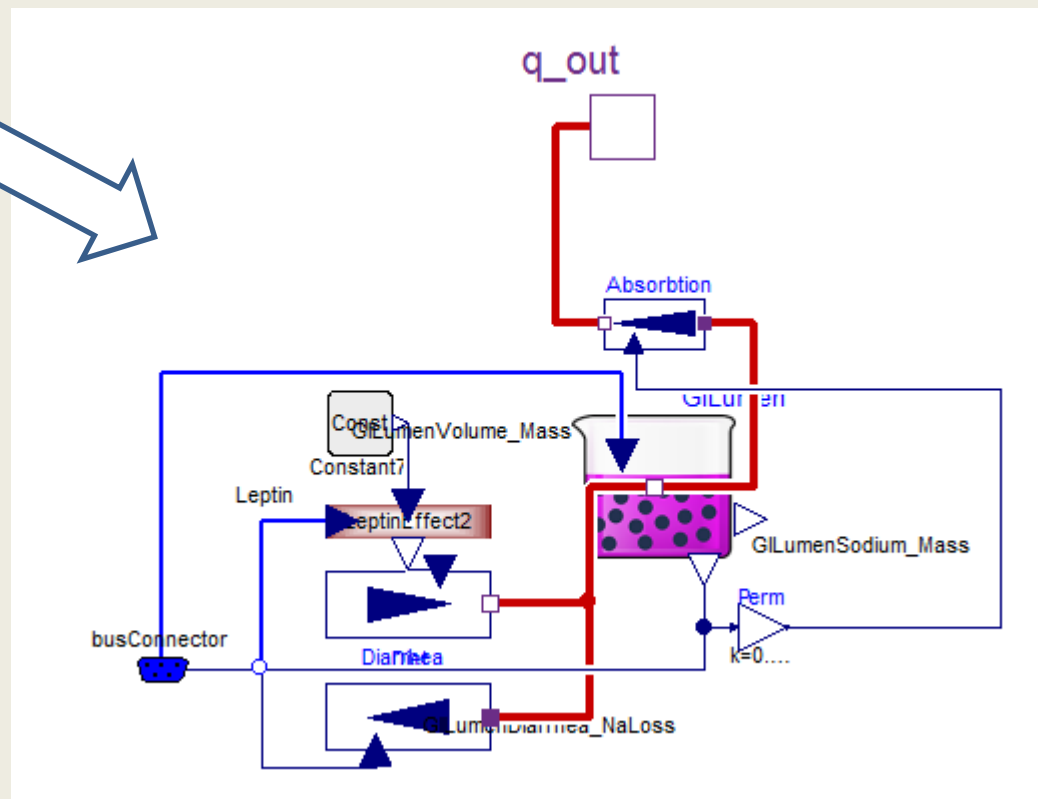
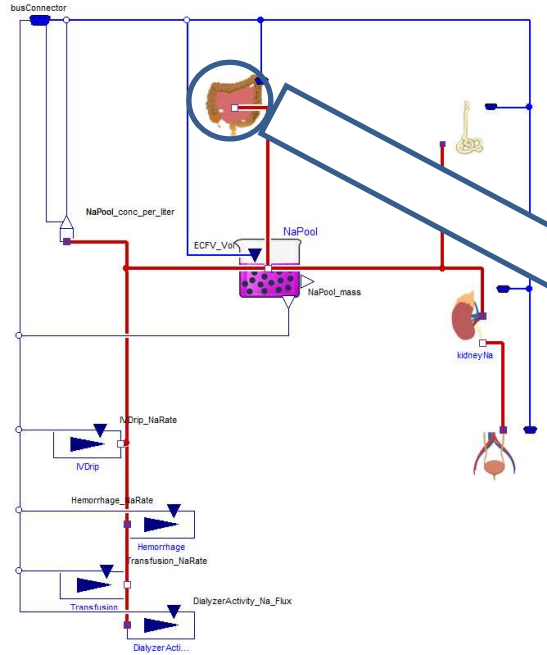

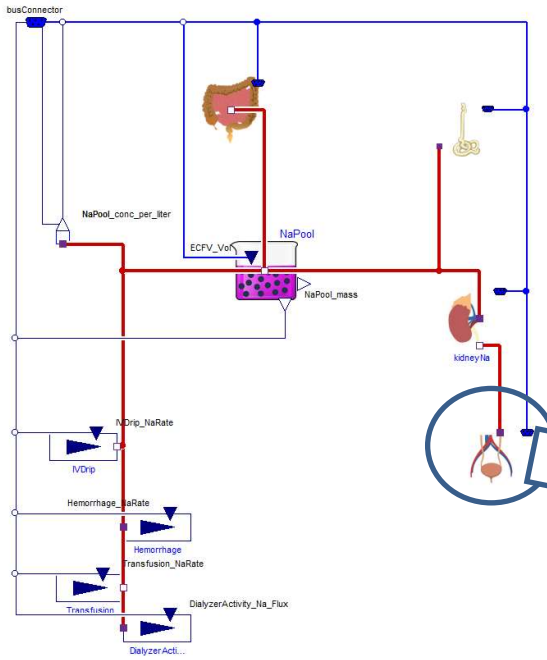

bladder

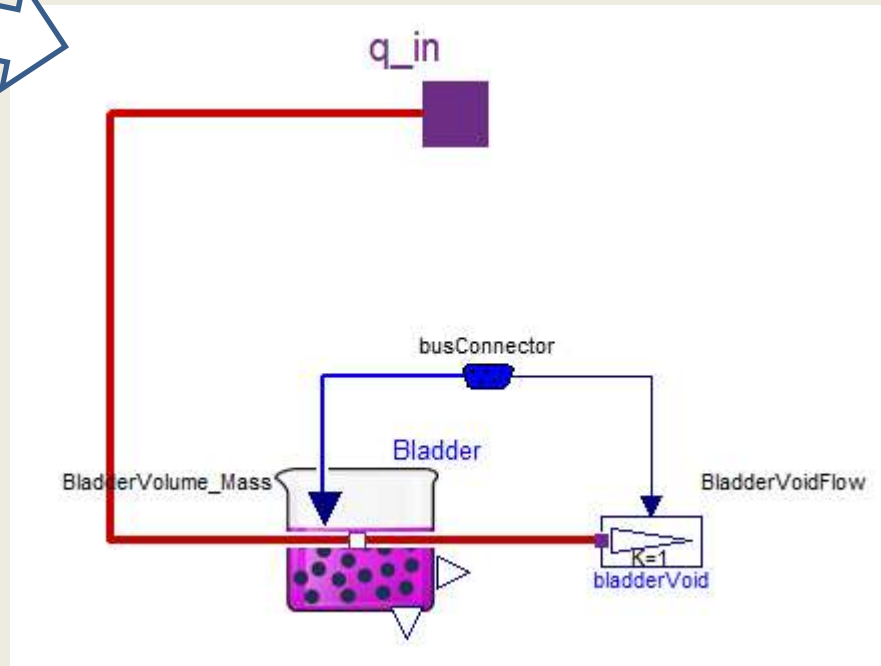

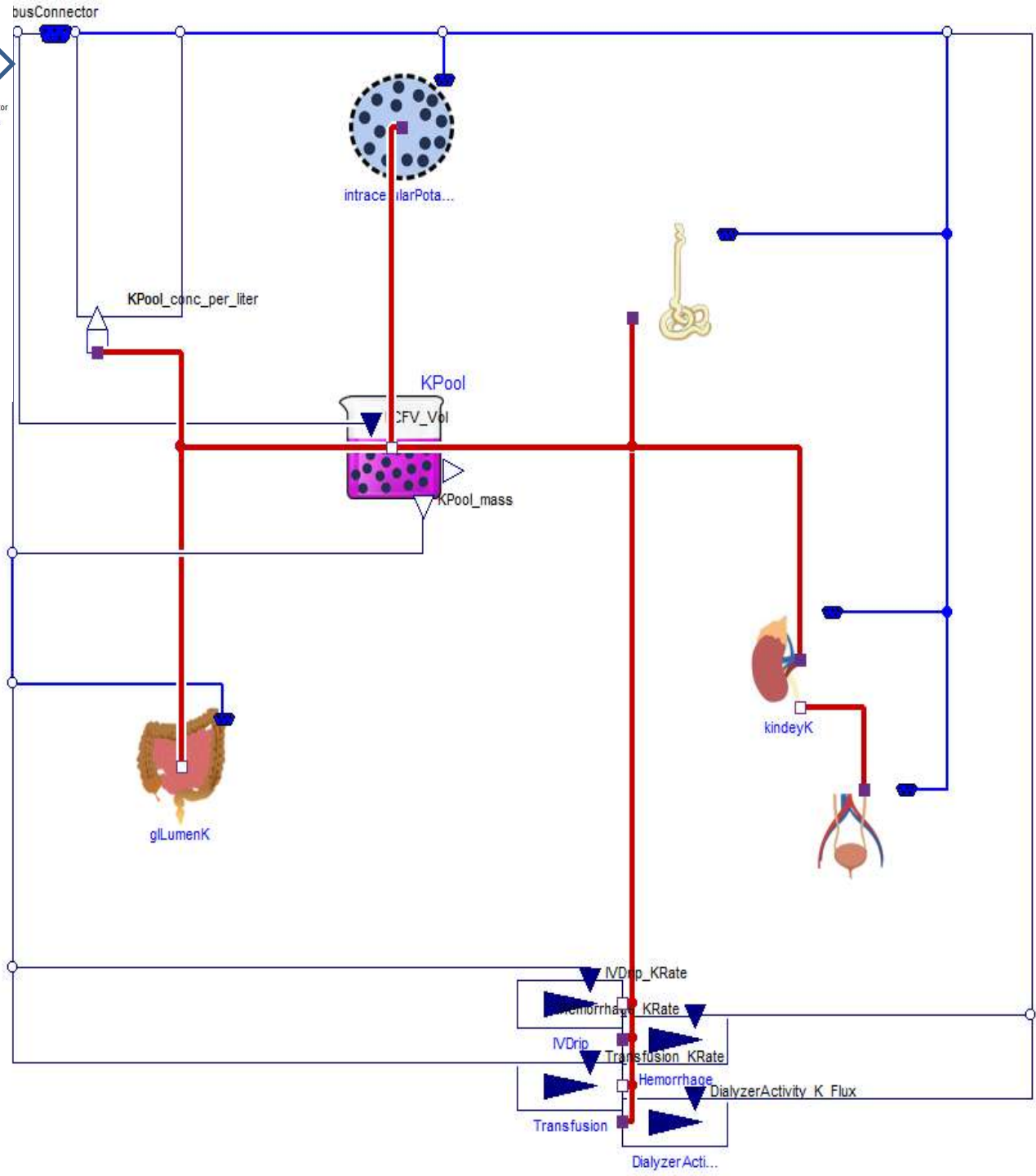
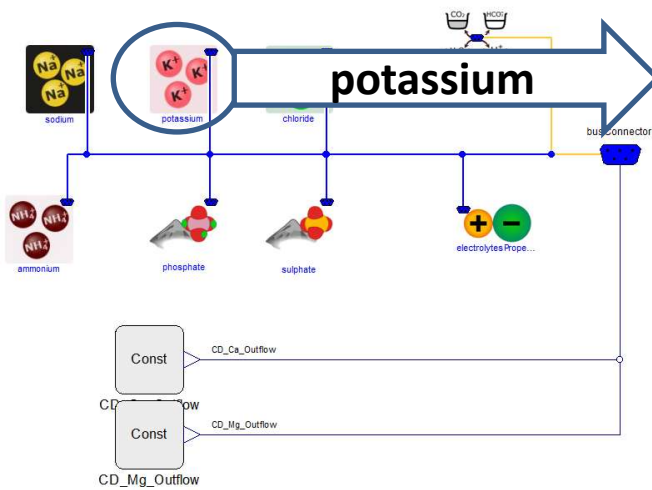

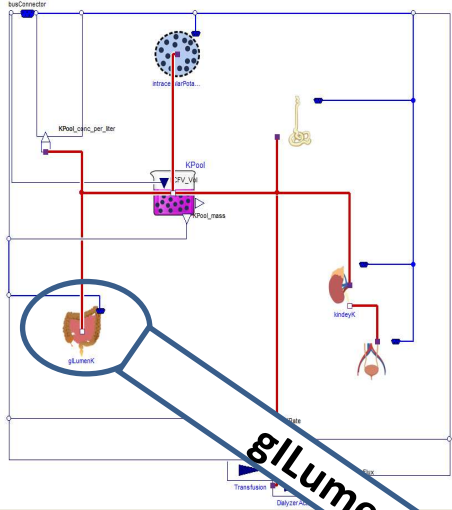

gILumen

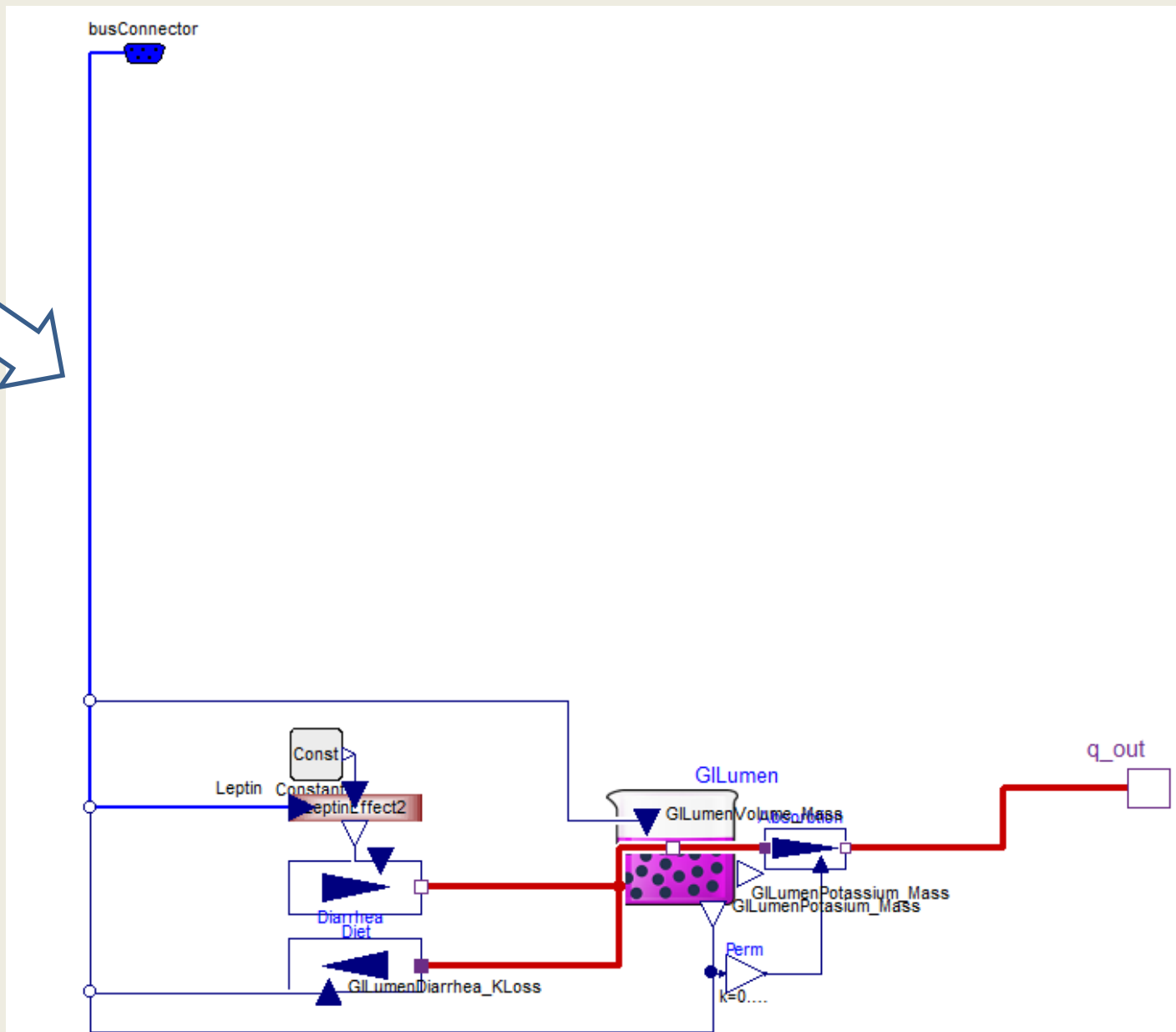

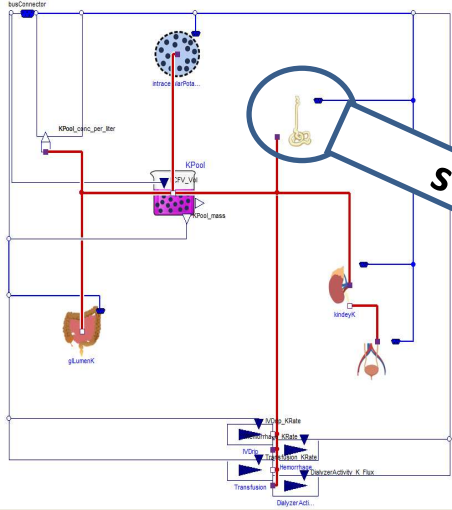

sweatGlandSalt

busConnector

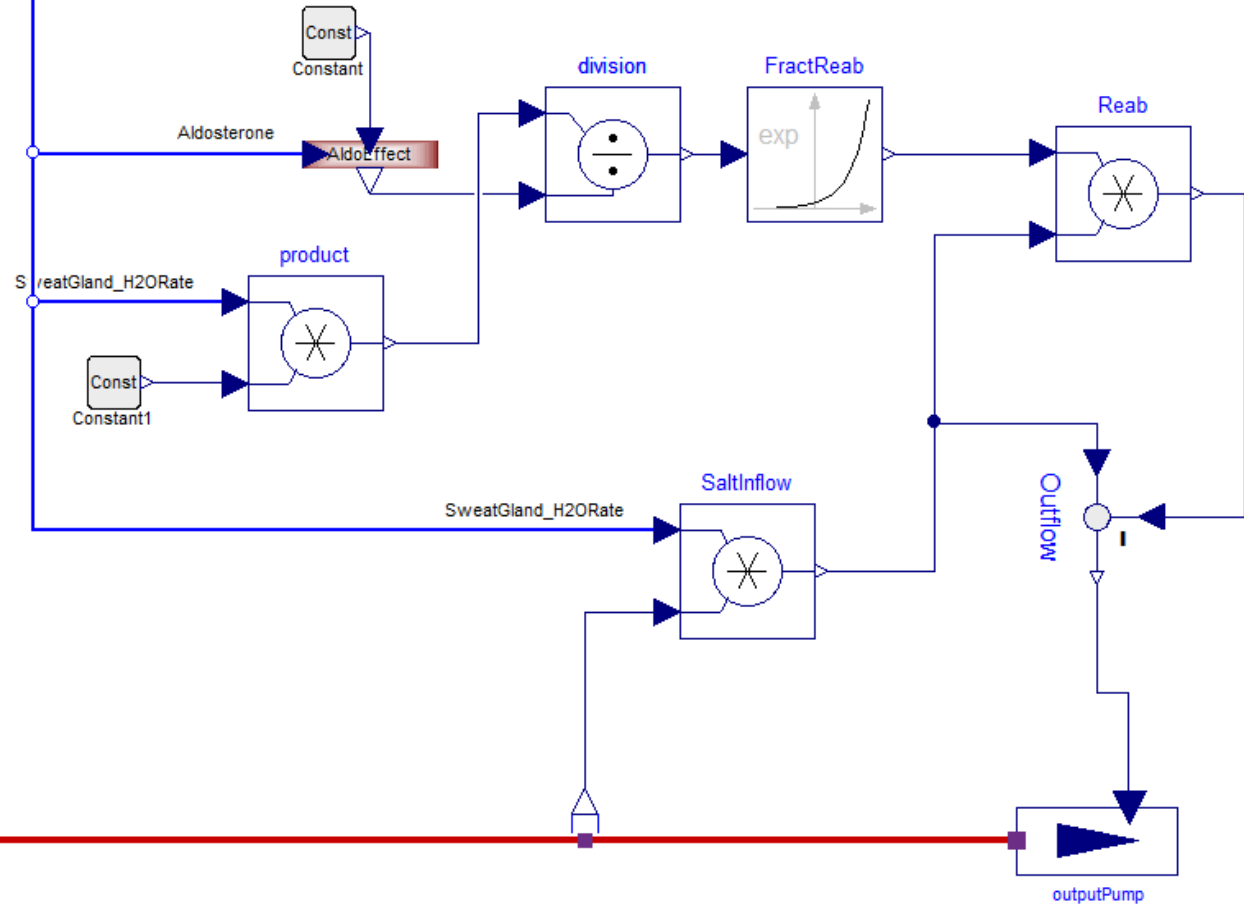

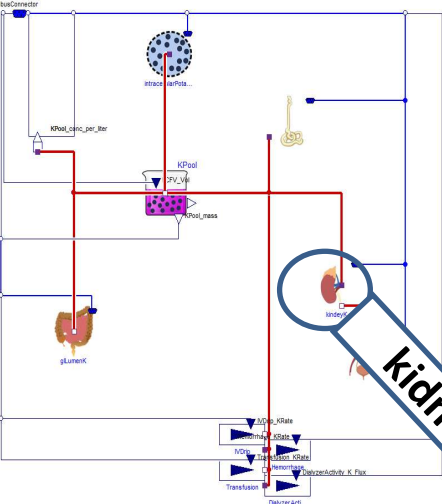

kidneyK

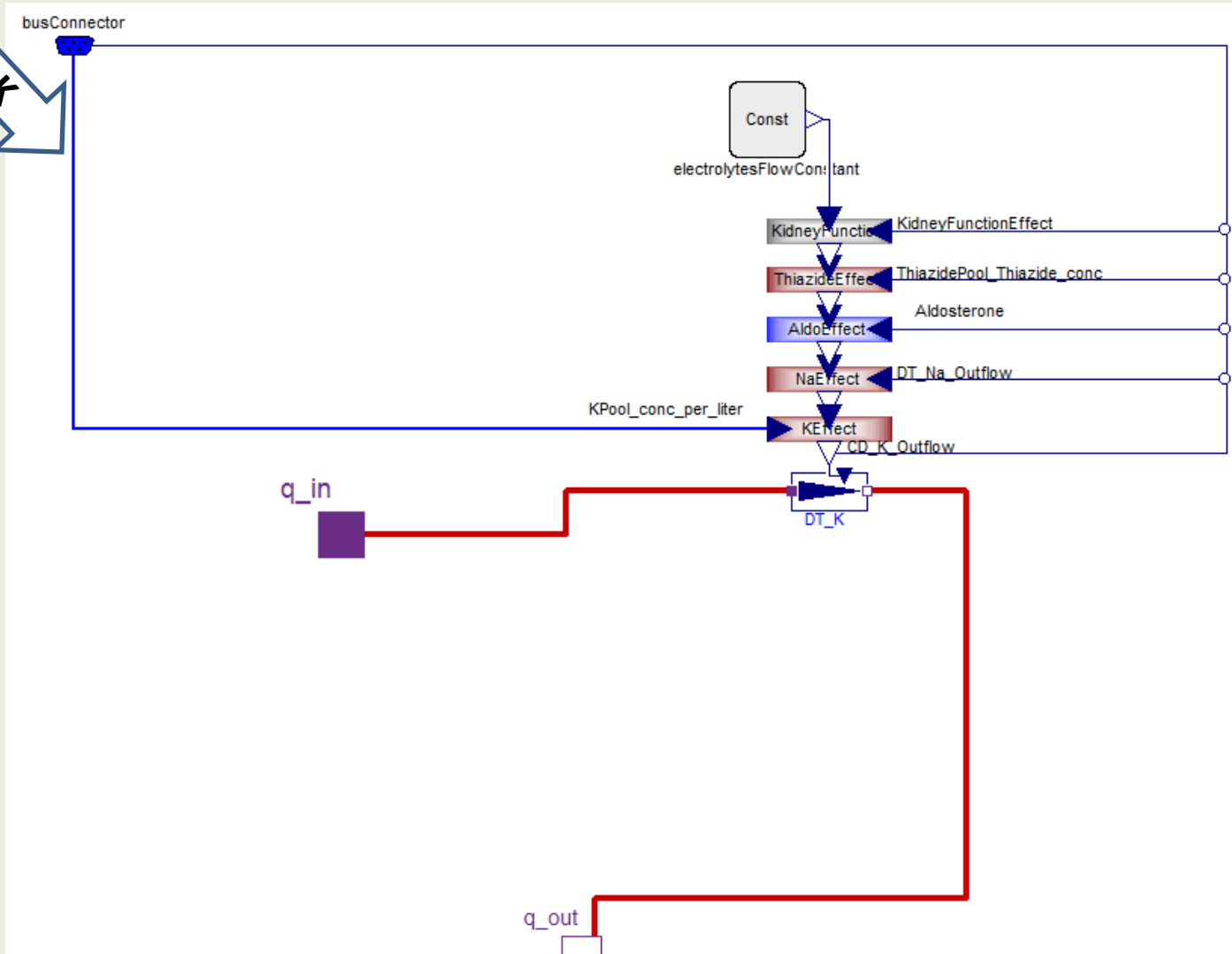

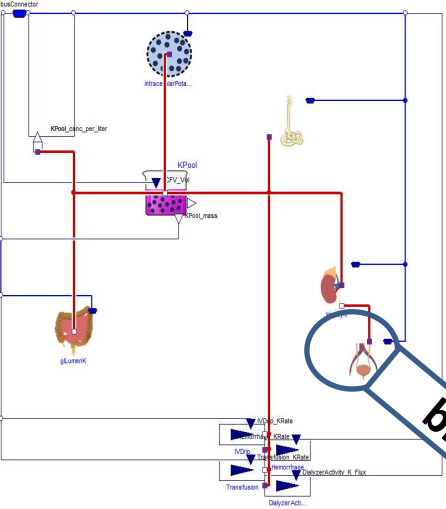

bladder

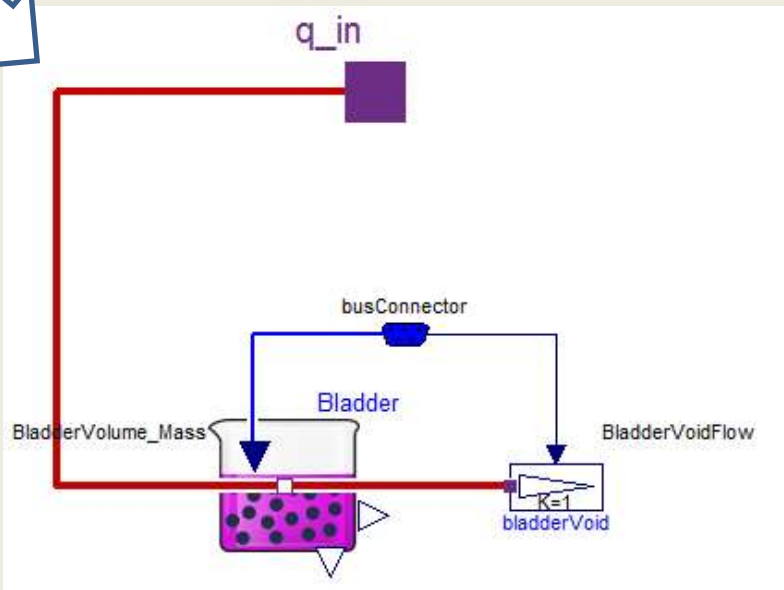

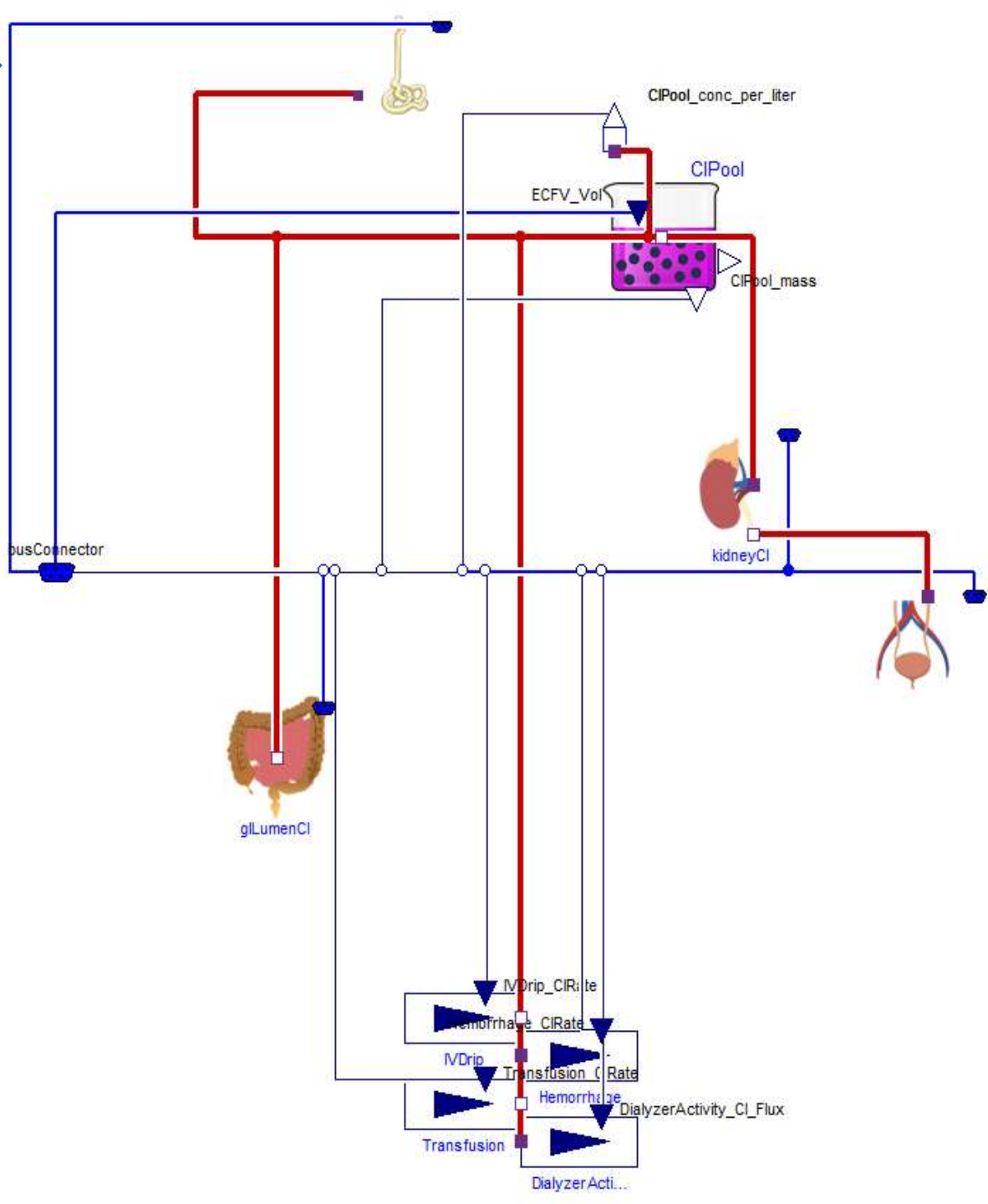
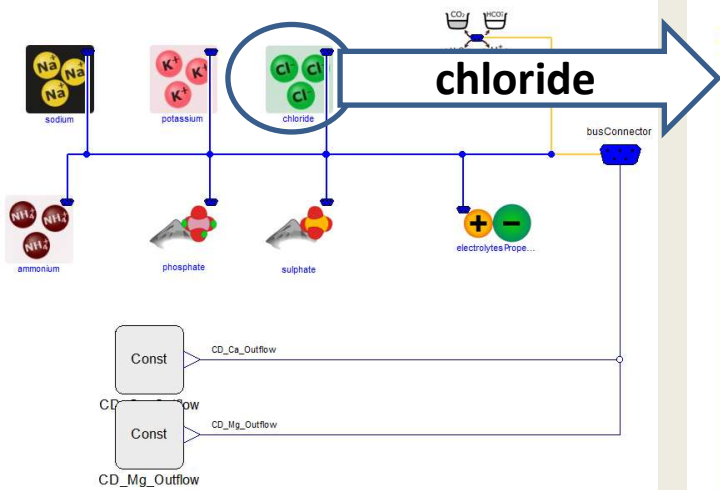

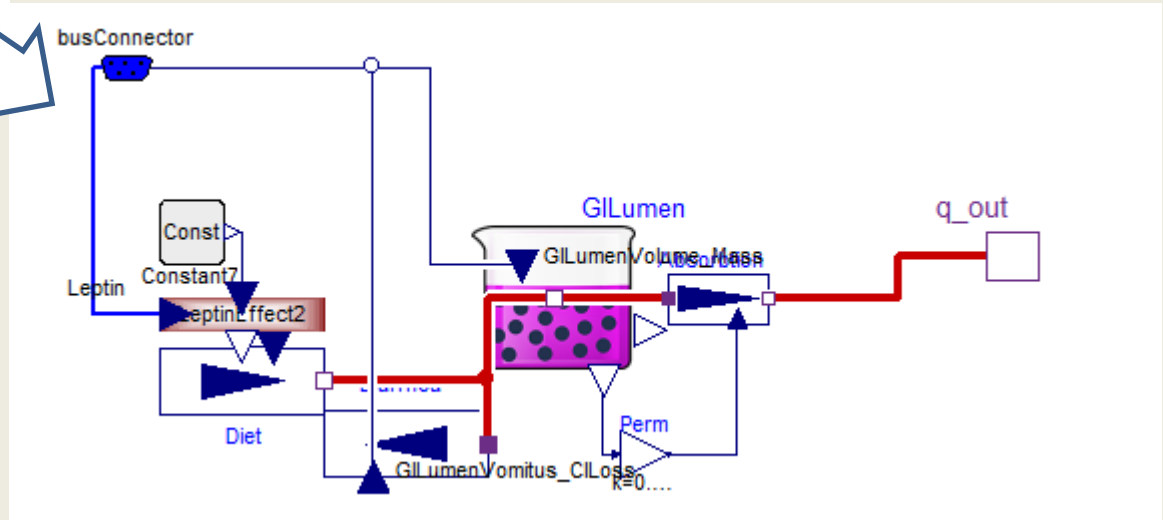
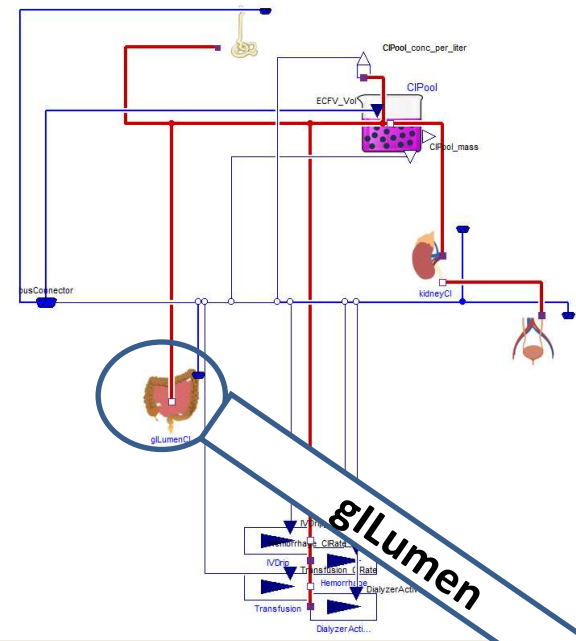

SweatGlandSalt

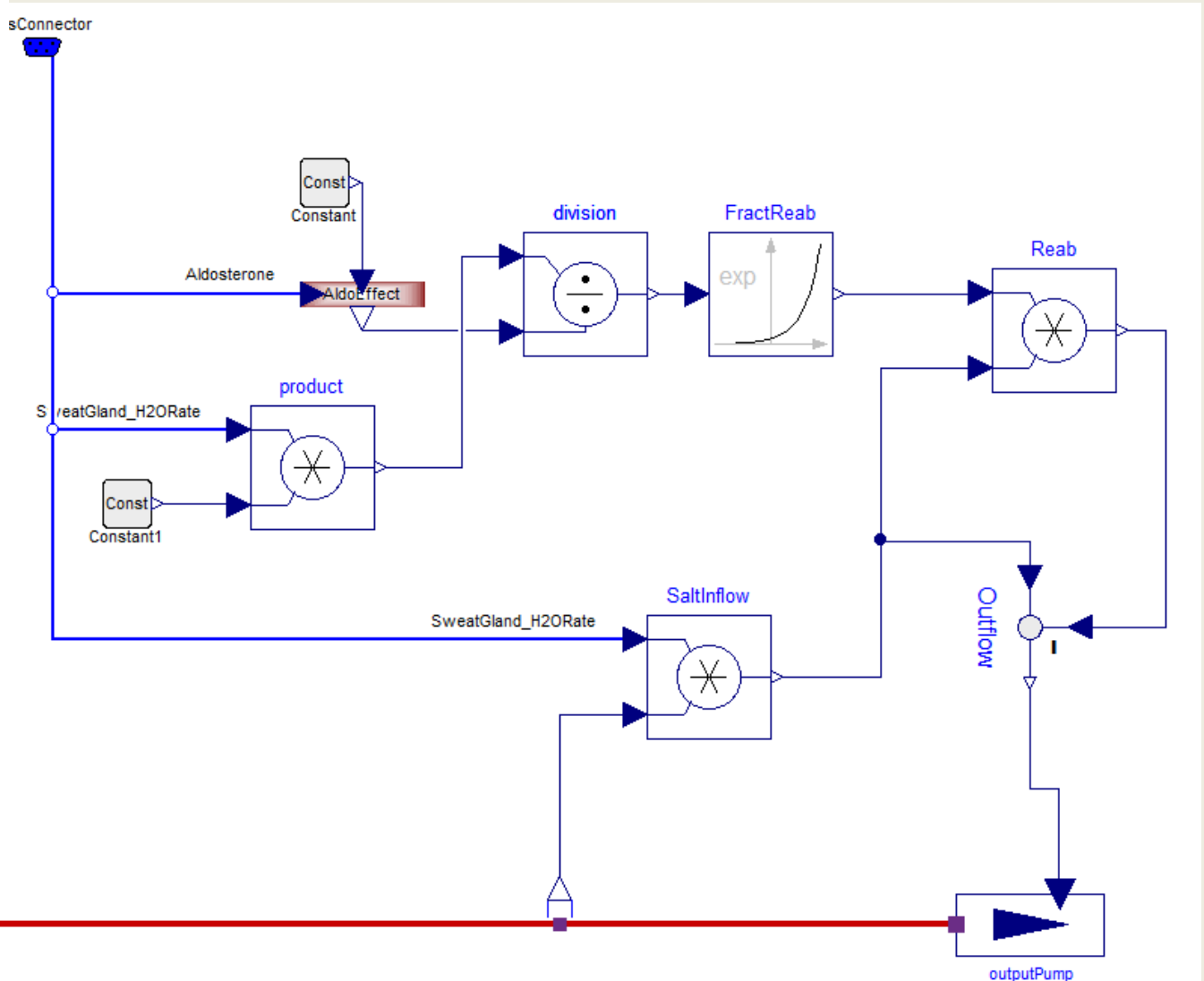
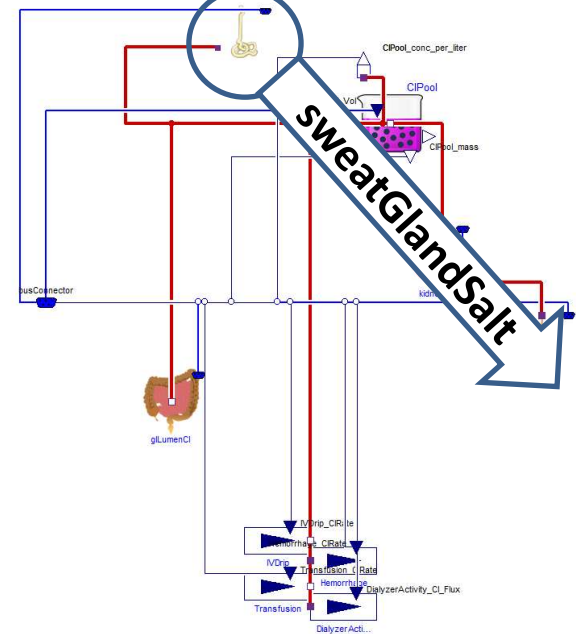

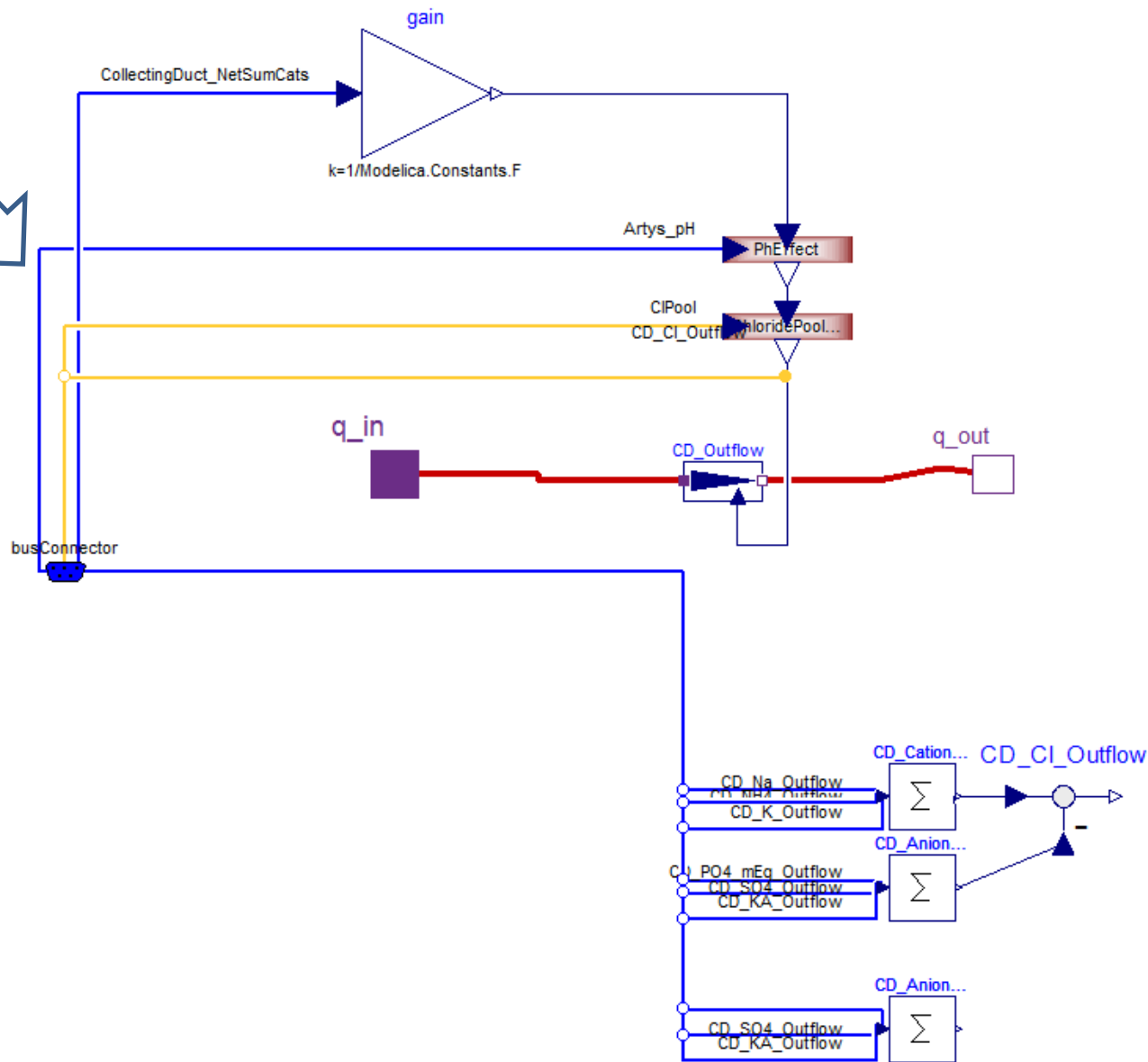
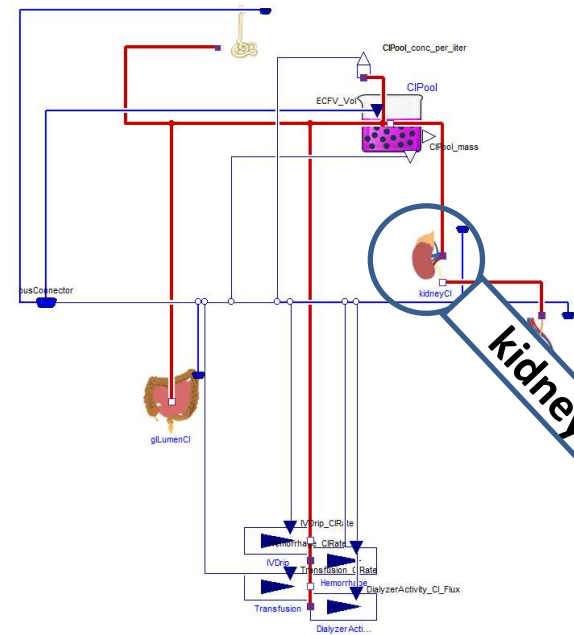

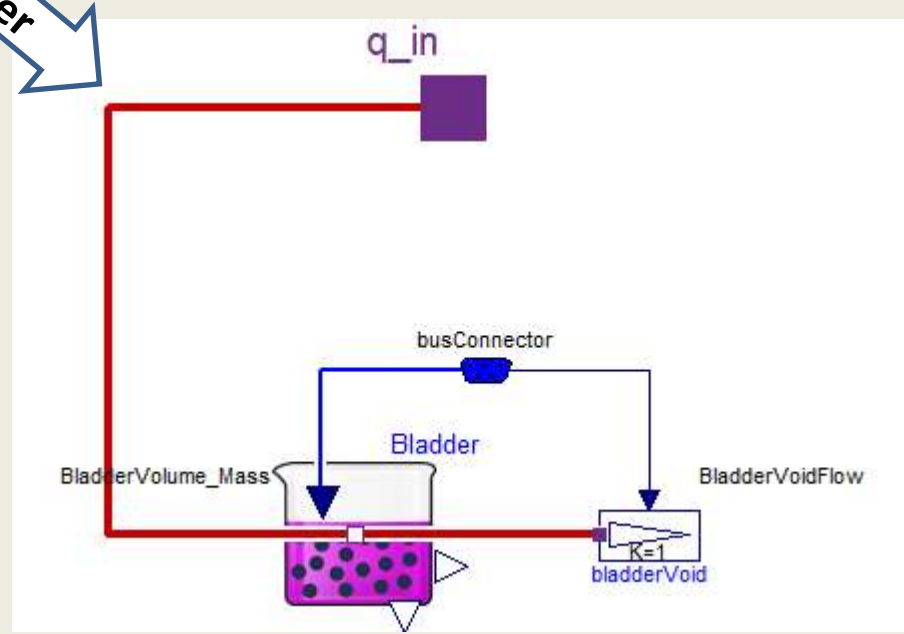
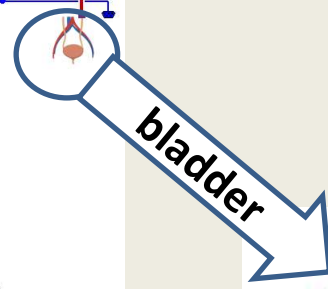
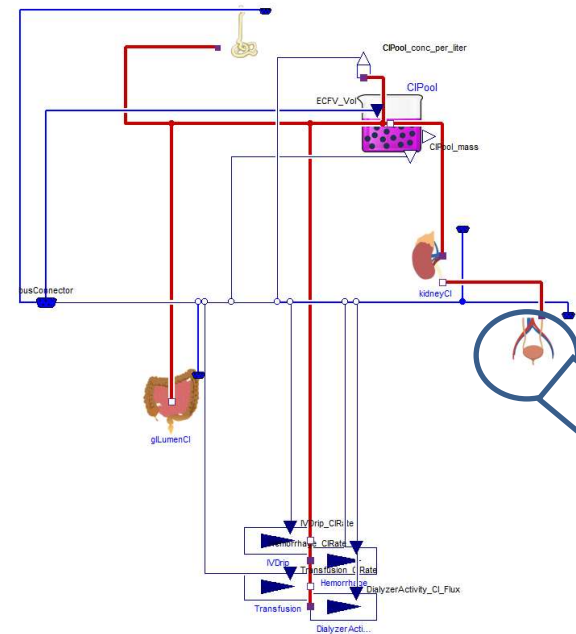

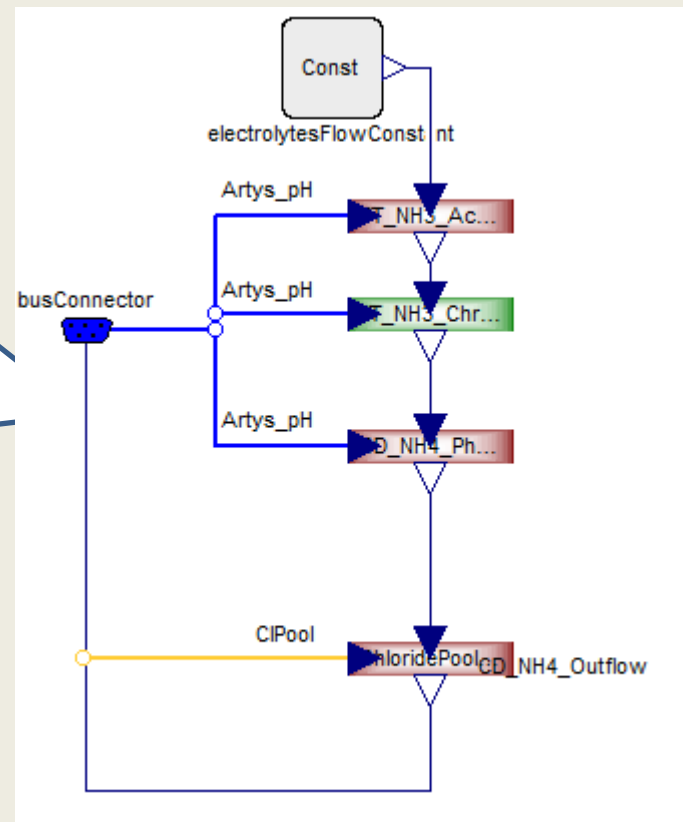
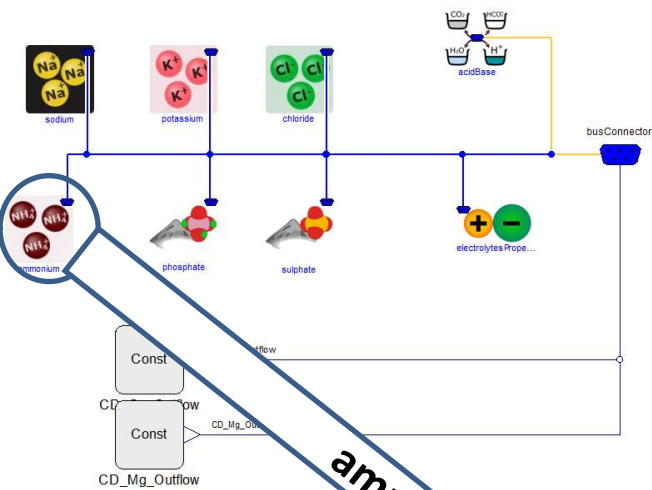

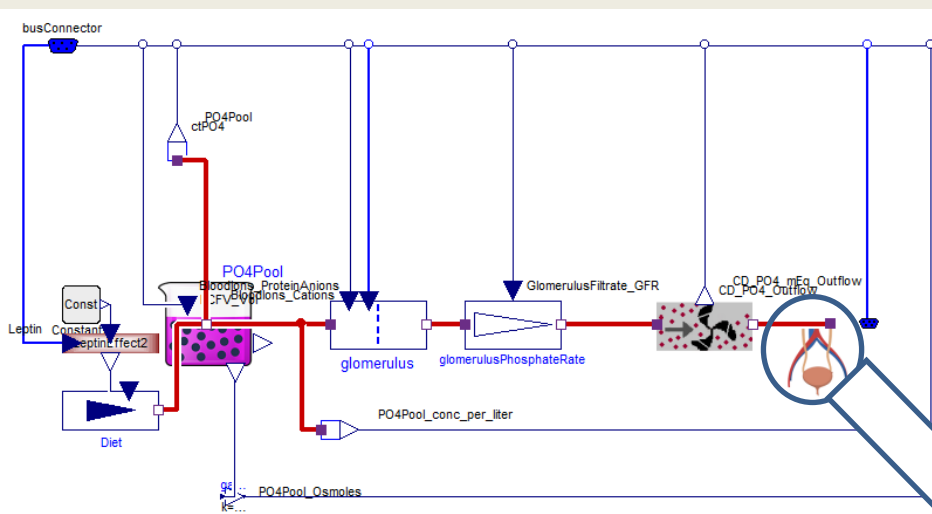

bladder

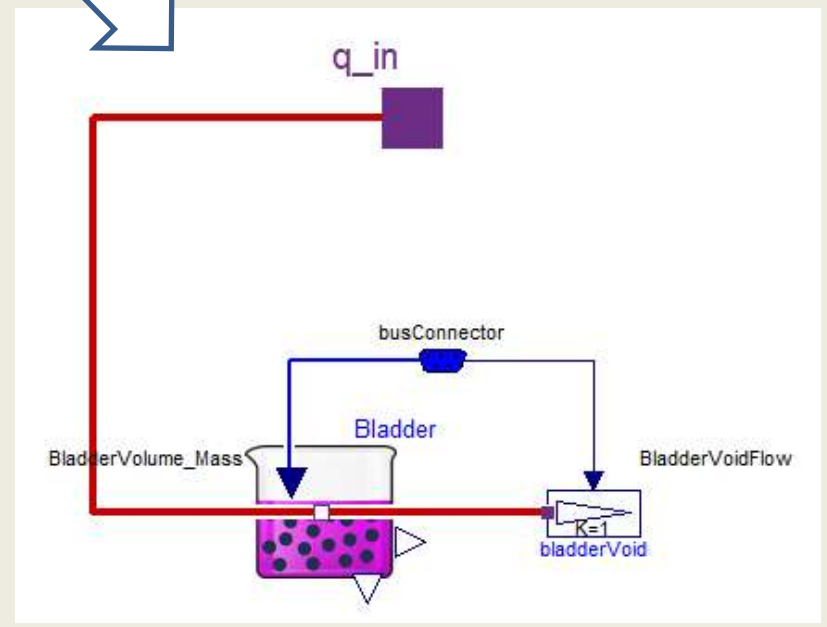

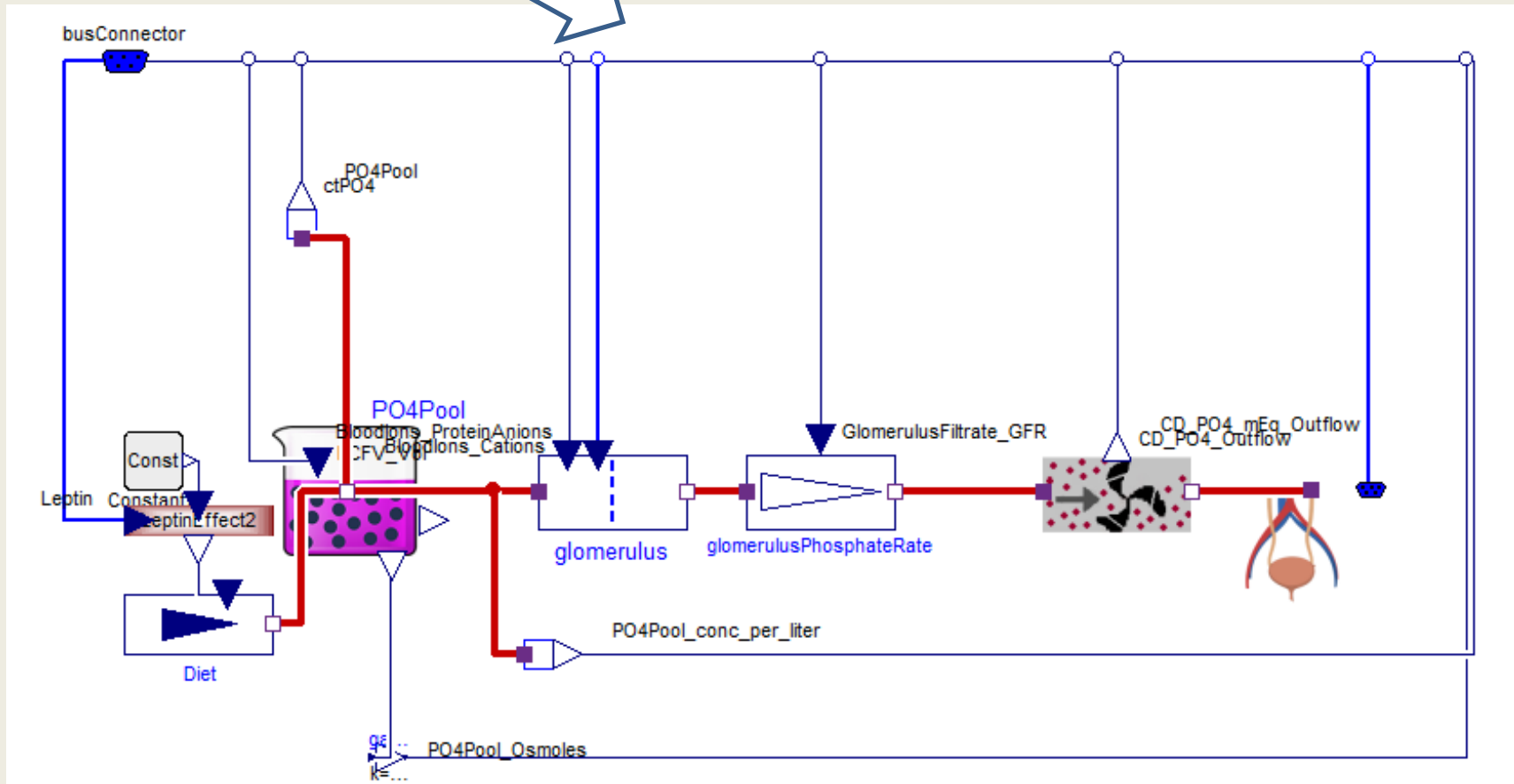
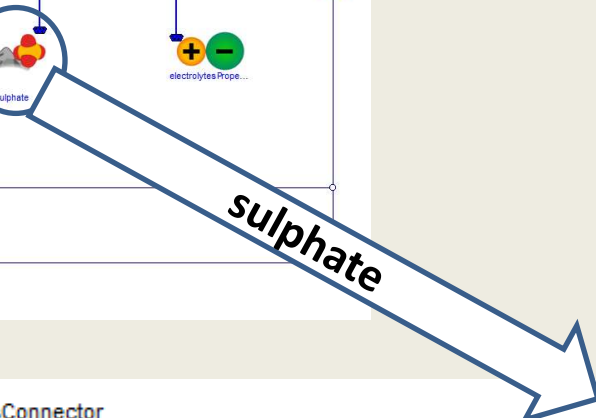
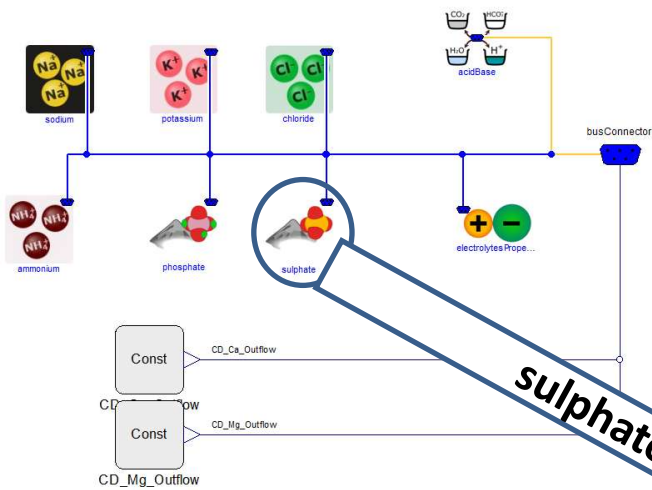

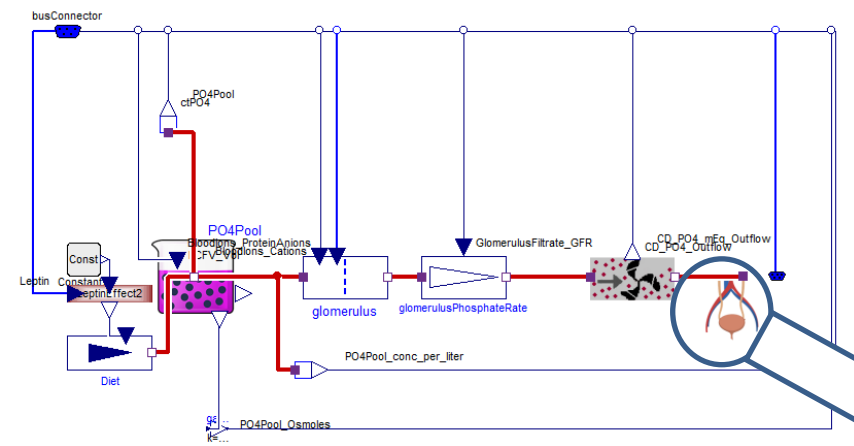

bladder

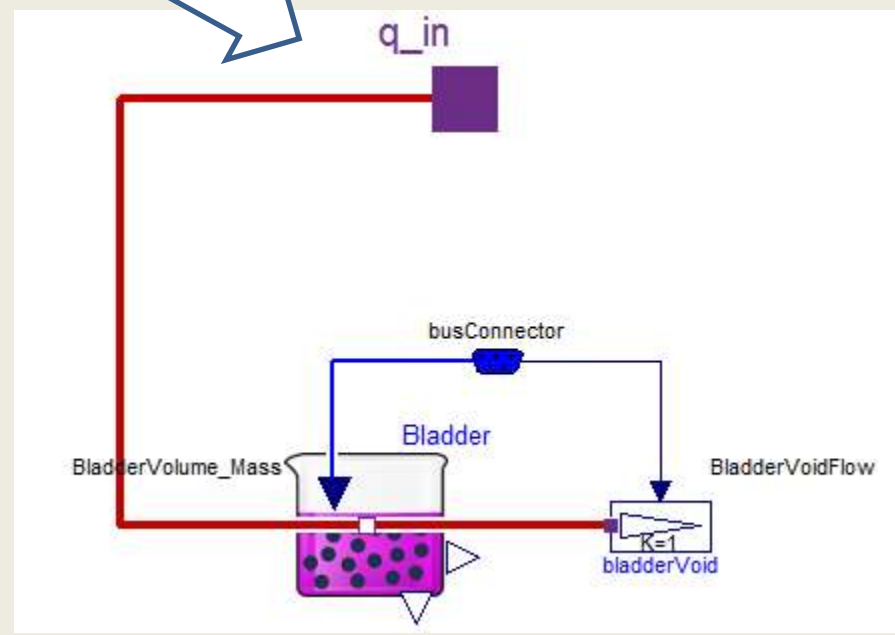

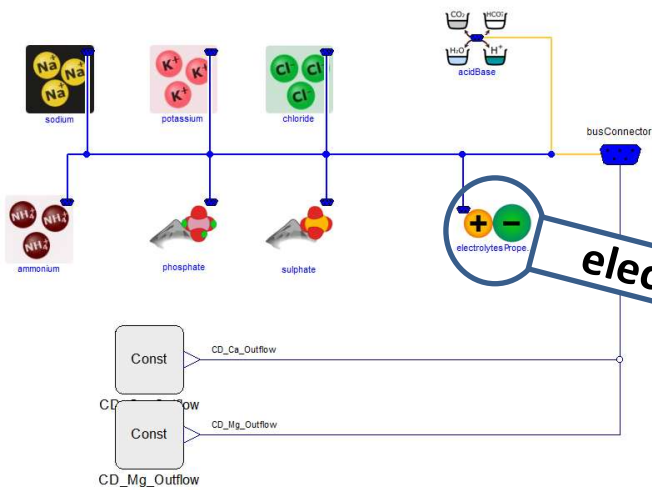

electrolytesProperties

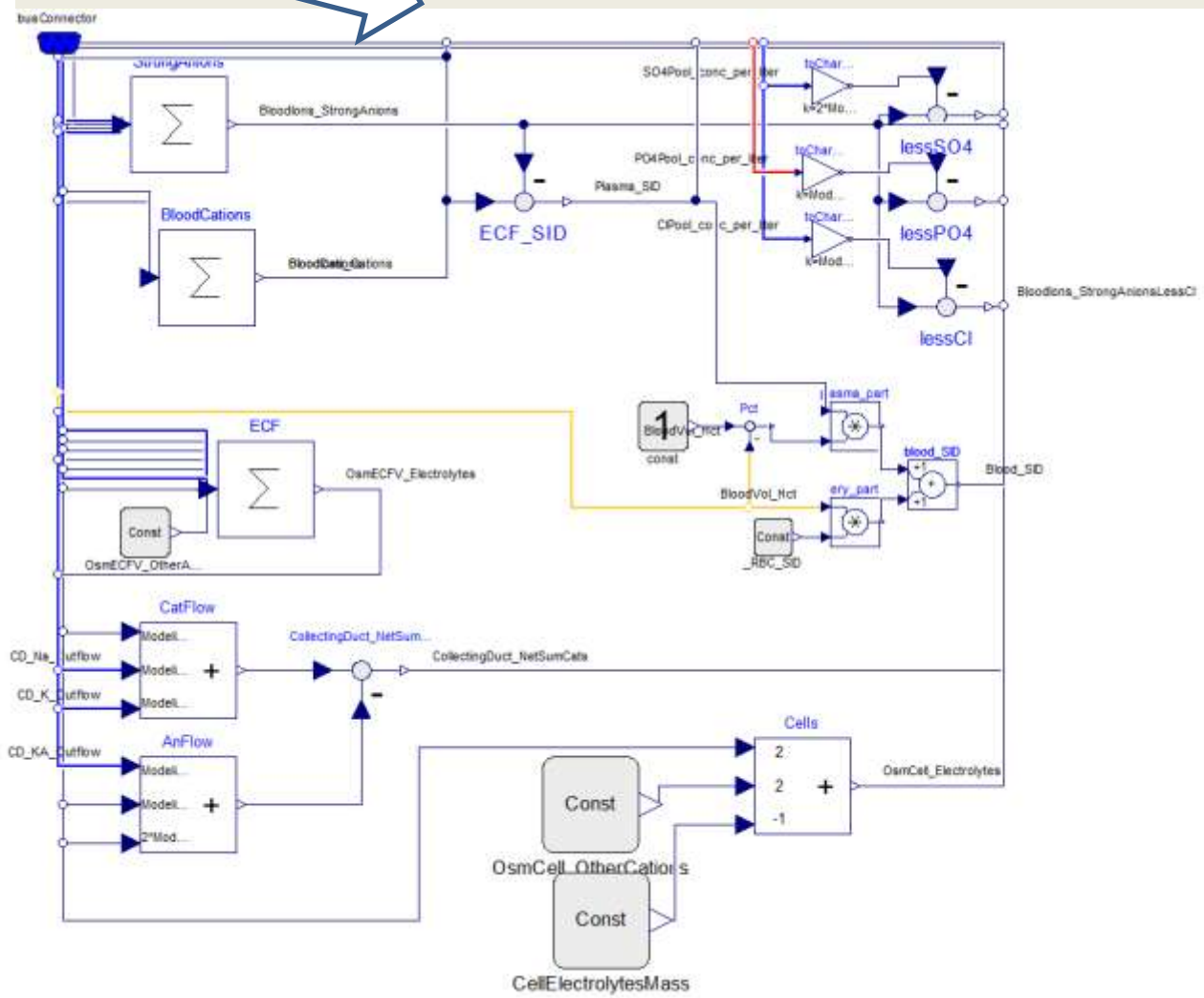

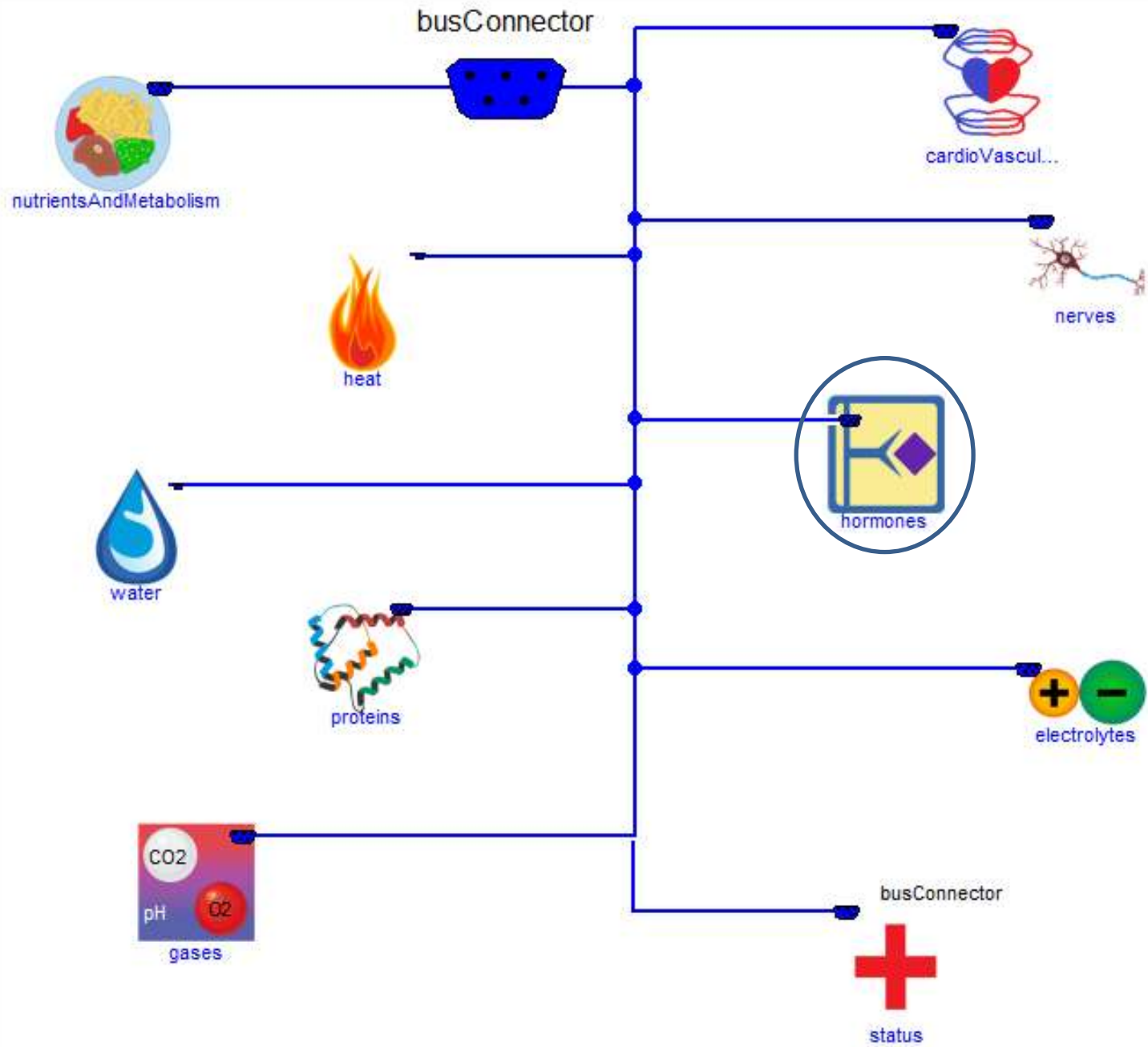

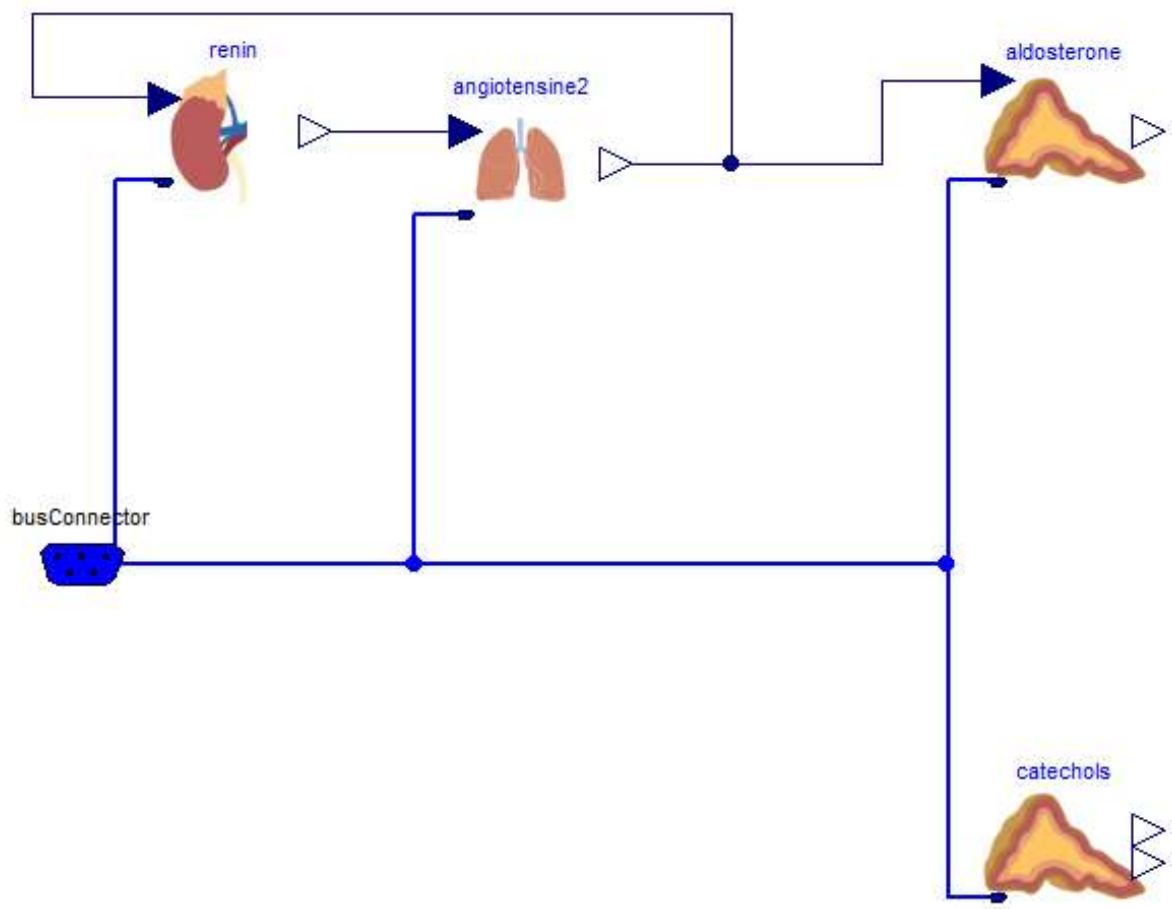
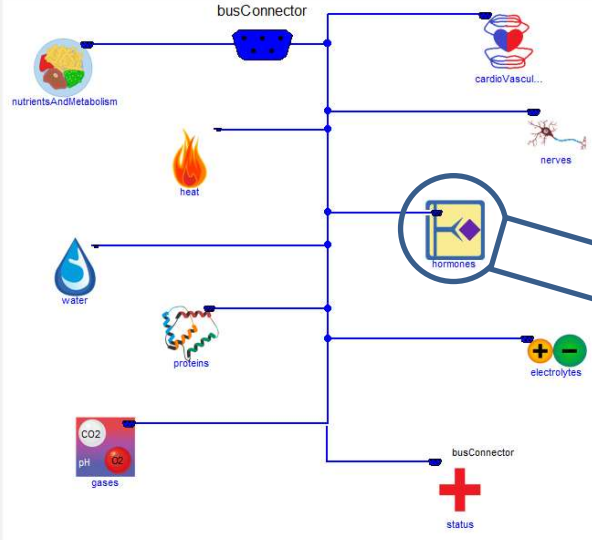

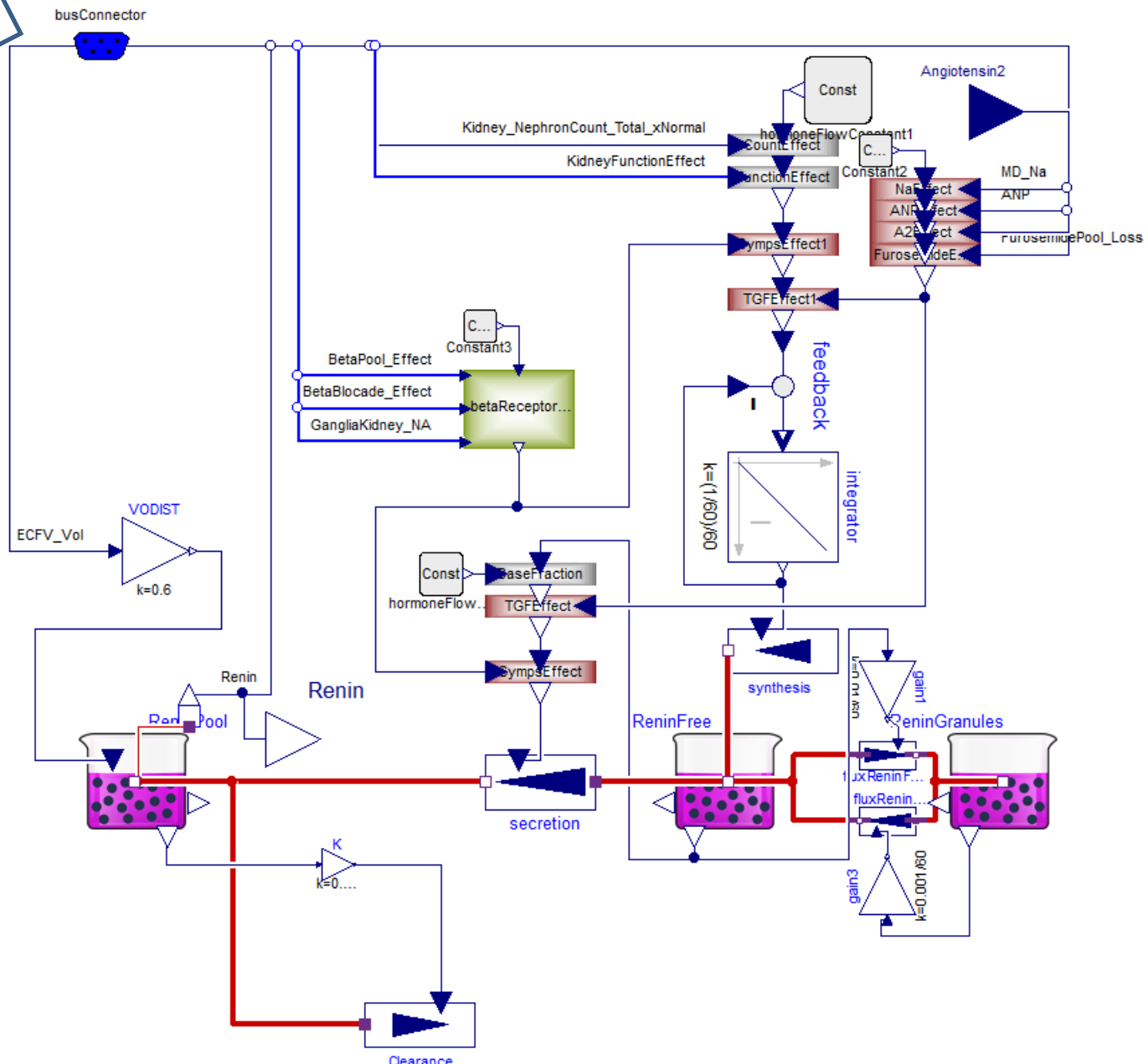
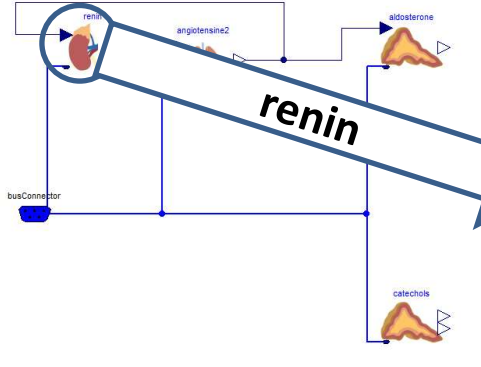

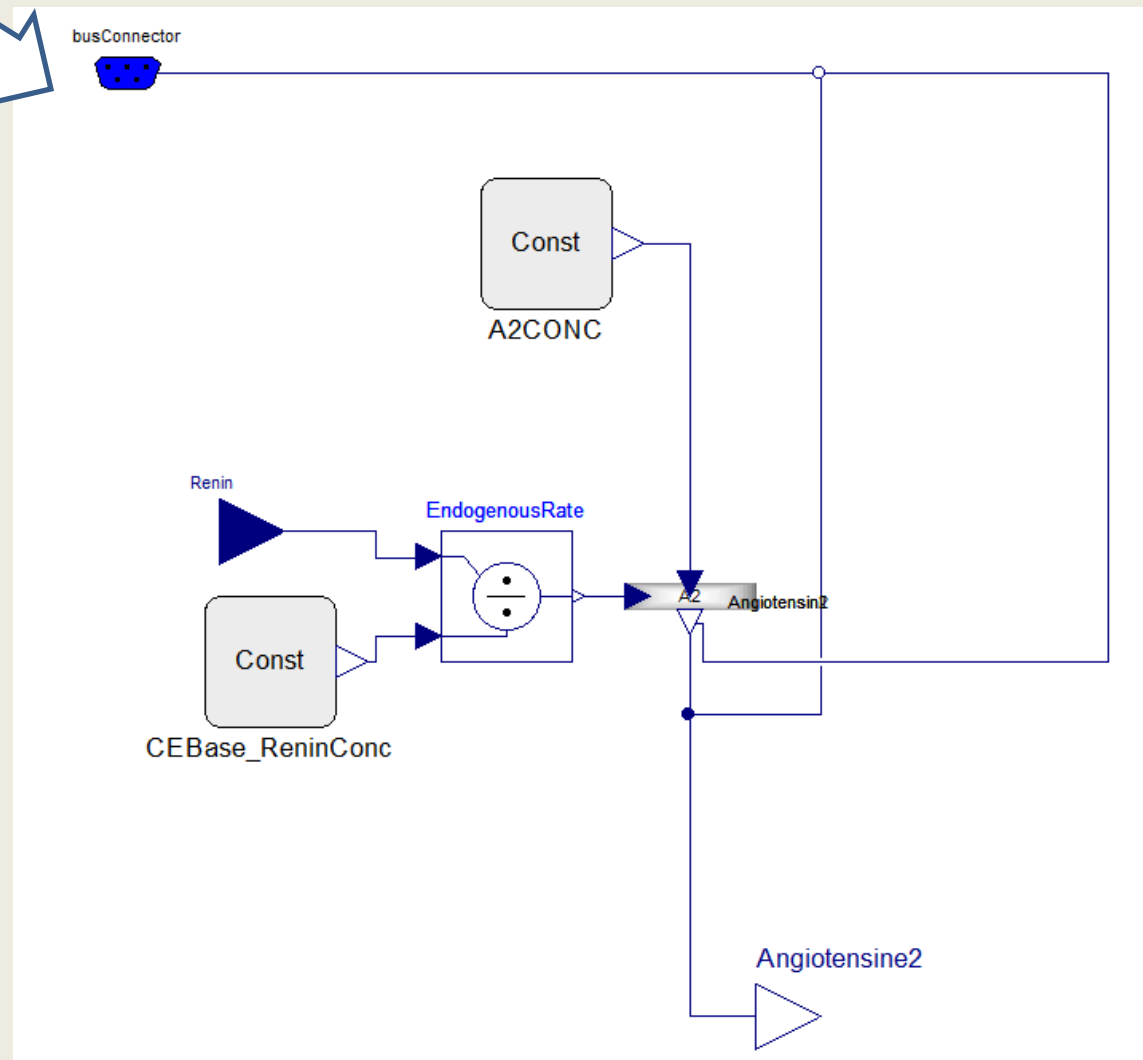
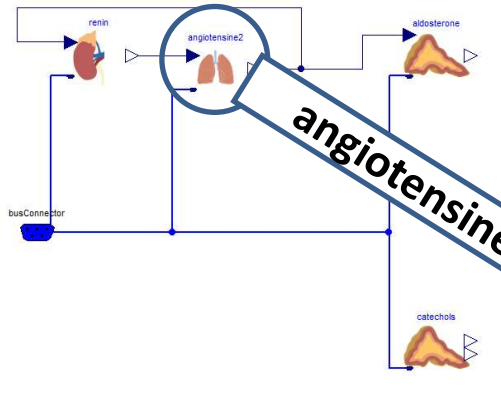

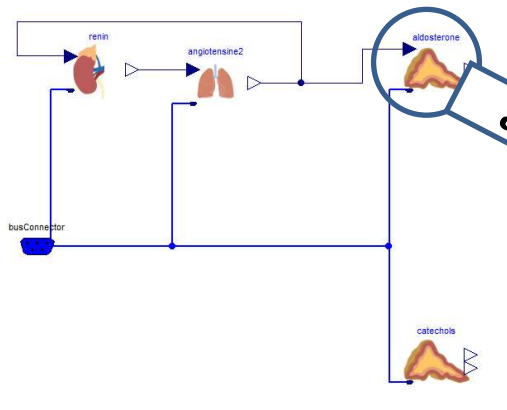

aldosterone

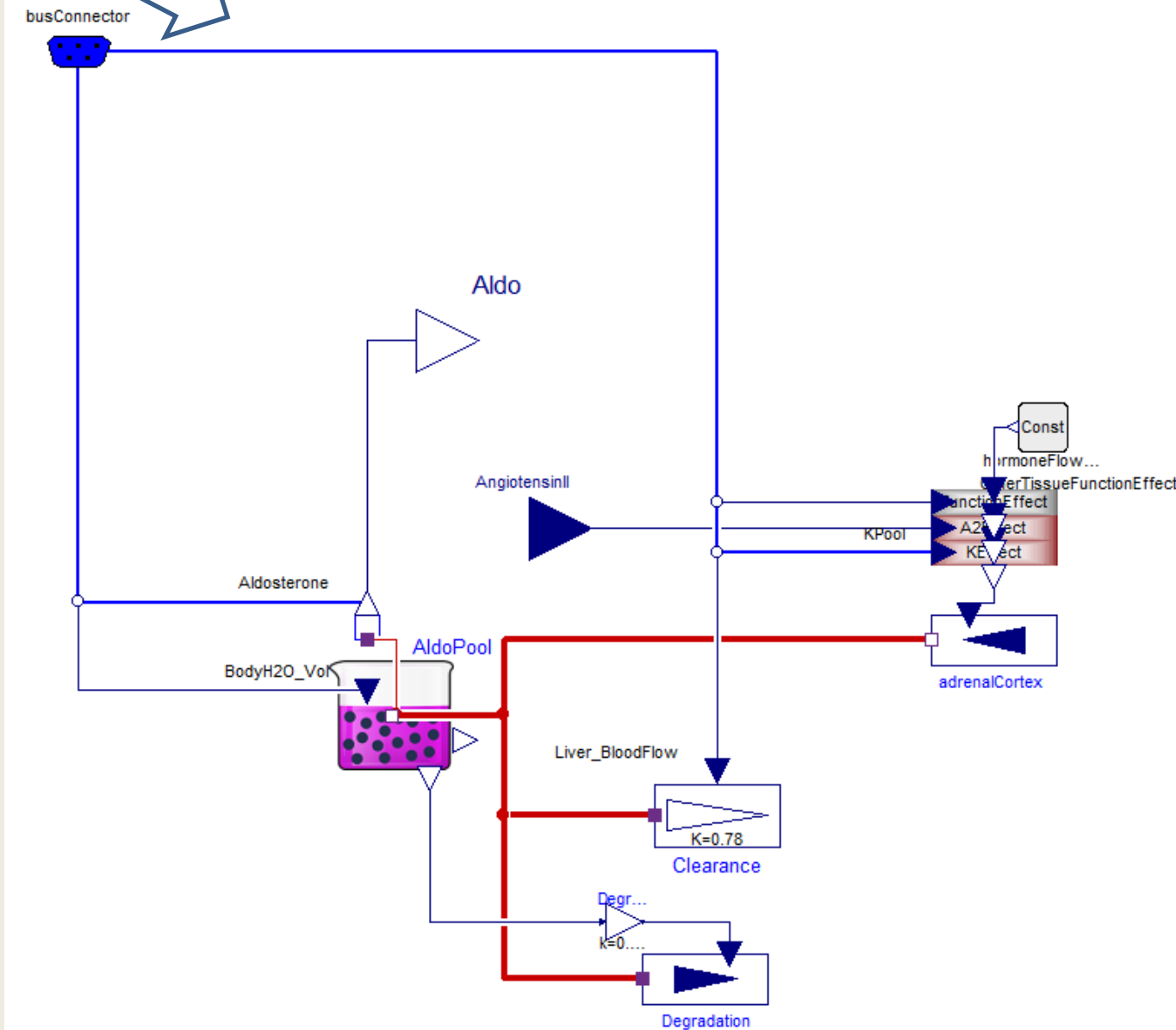

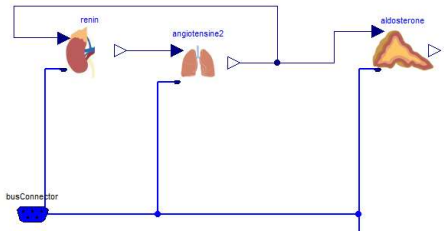

catechols

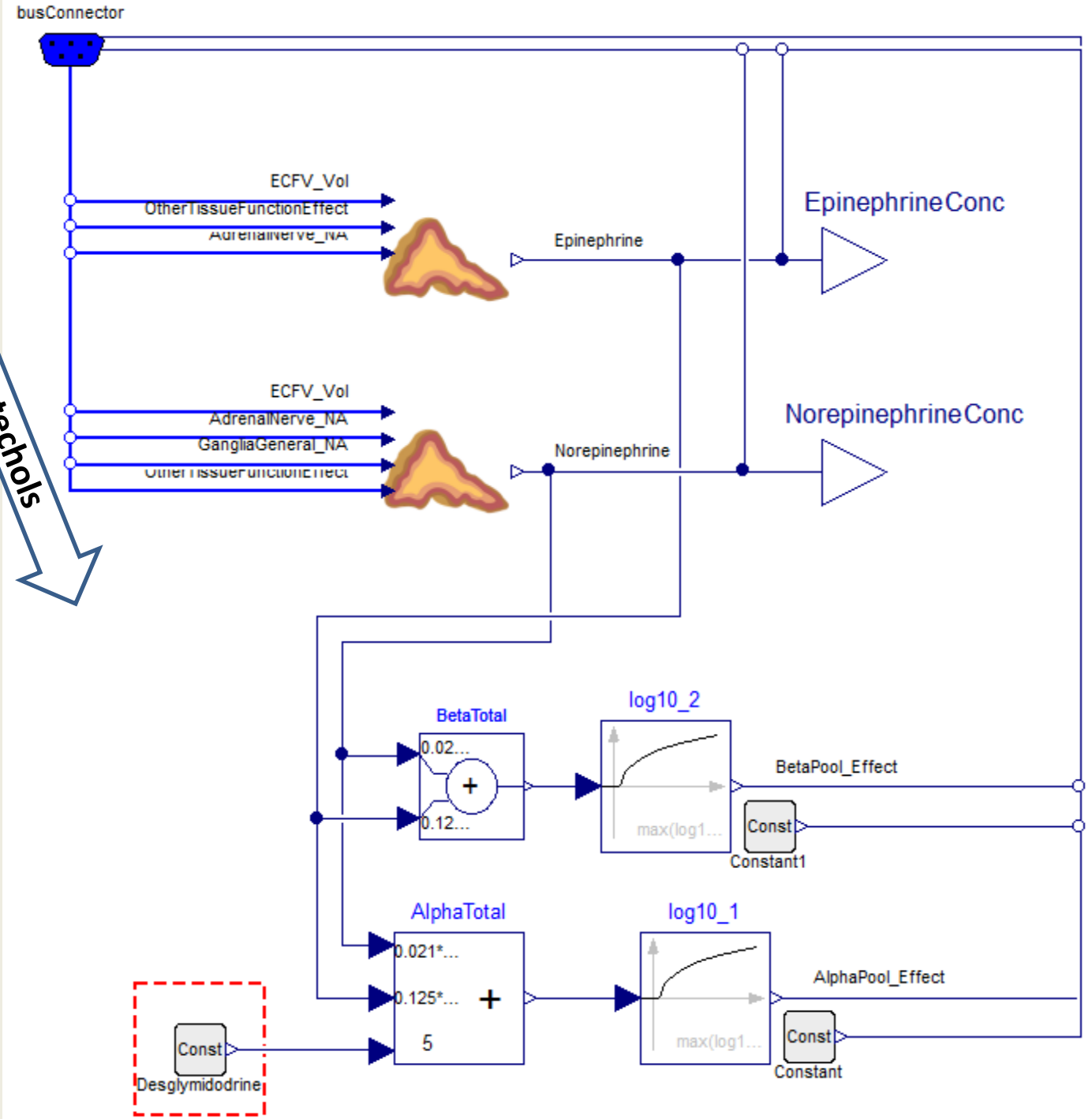

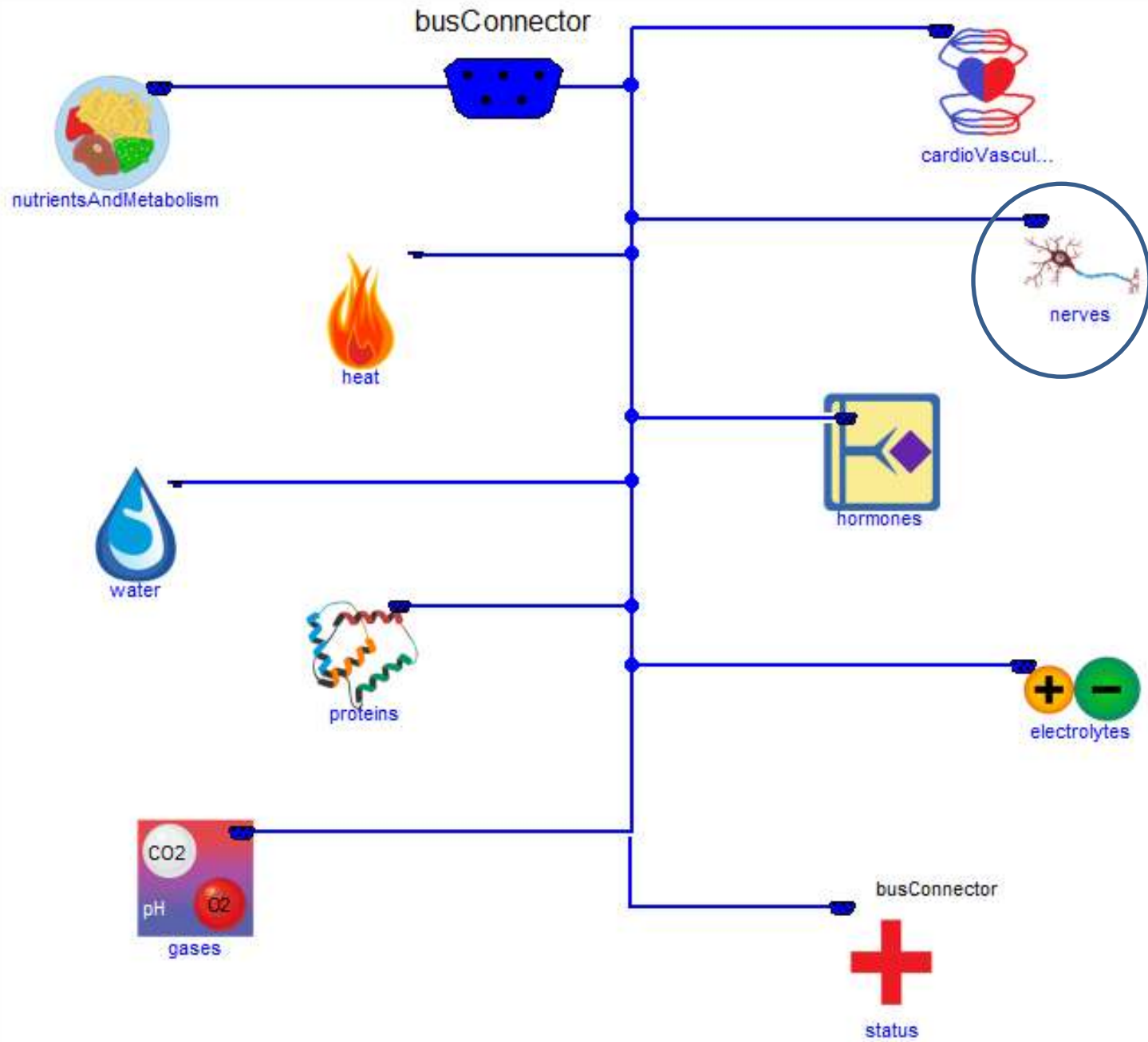

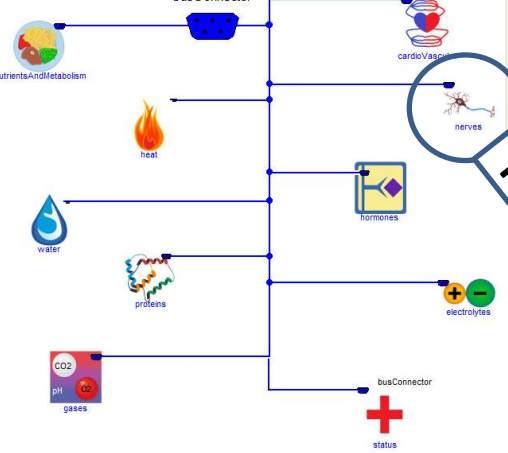

nerves

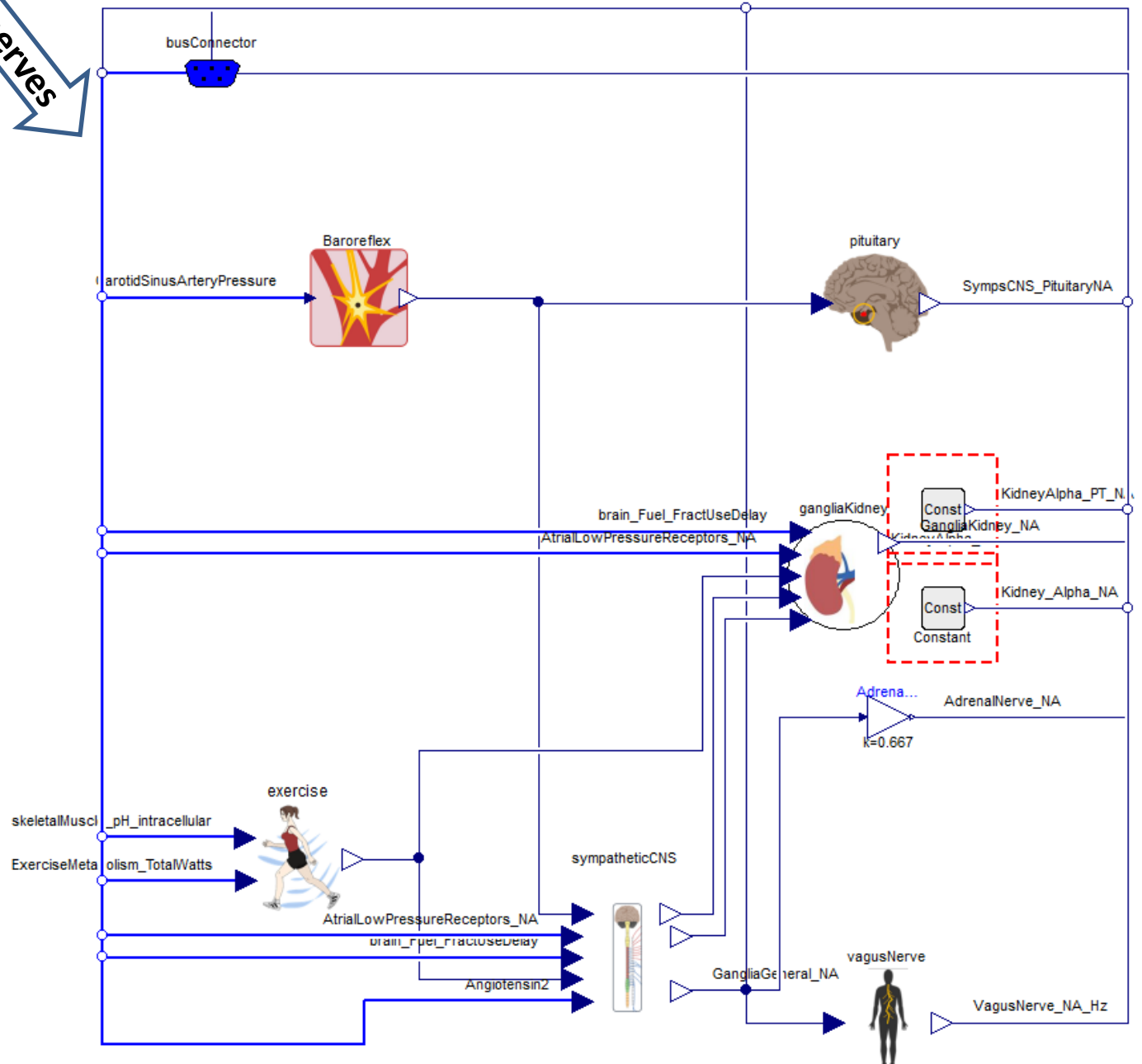

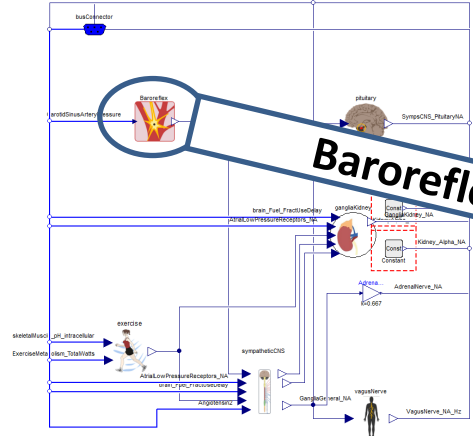

Baroreflex

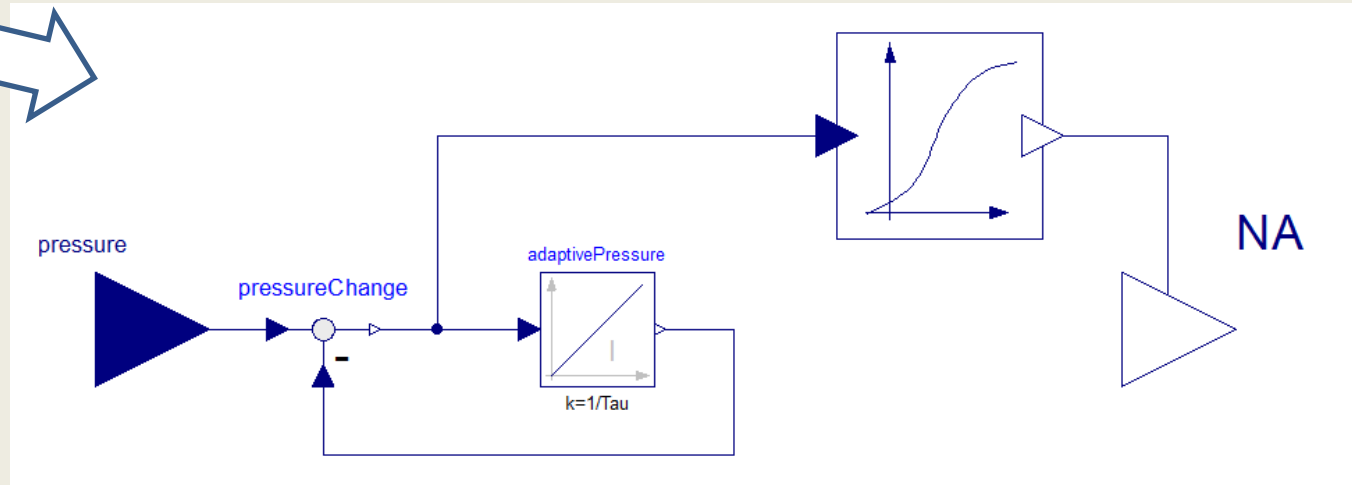

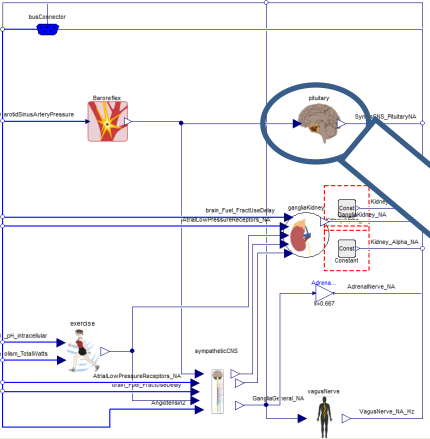

pituitary

Baroreflex_NA

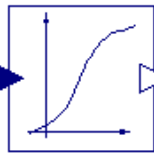
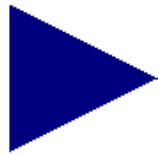

sub

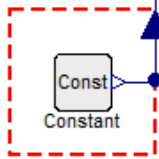

product

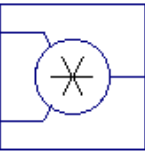

add

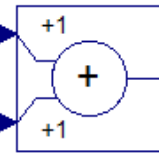

BaroEffect

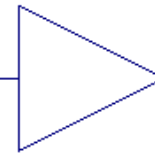

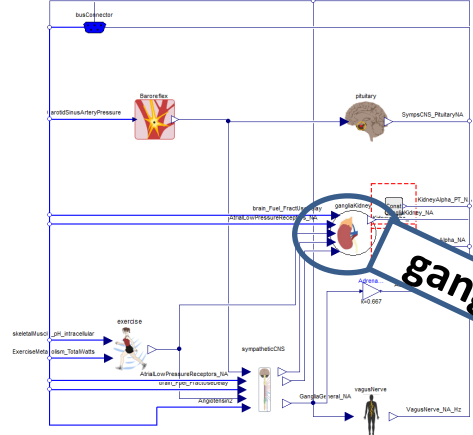

gangliaKidney

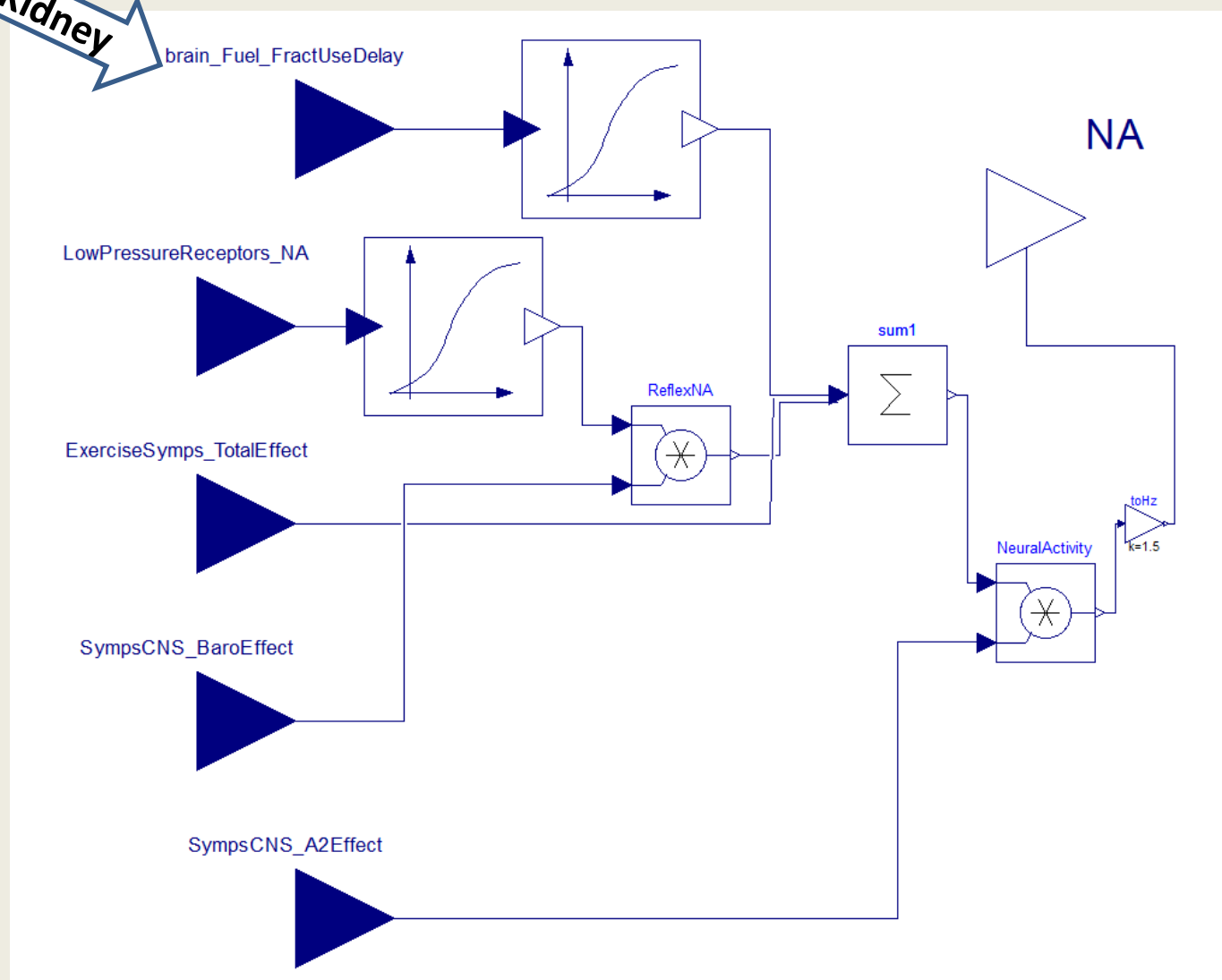

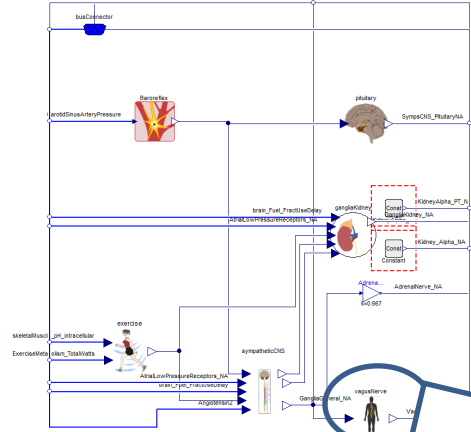

vagusNerve

SympS_CNS_NA_Hz

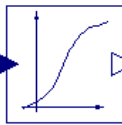
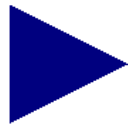

VagusNerve_NA_Hz

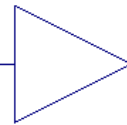

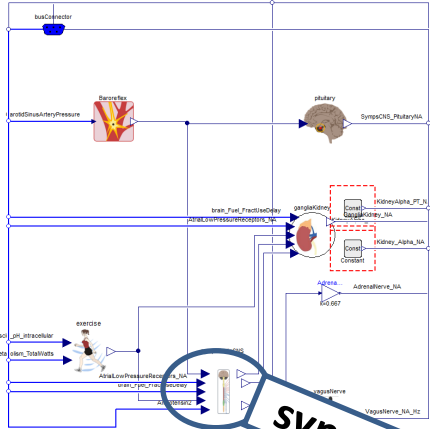

sympatheticCNS

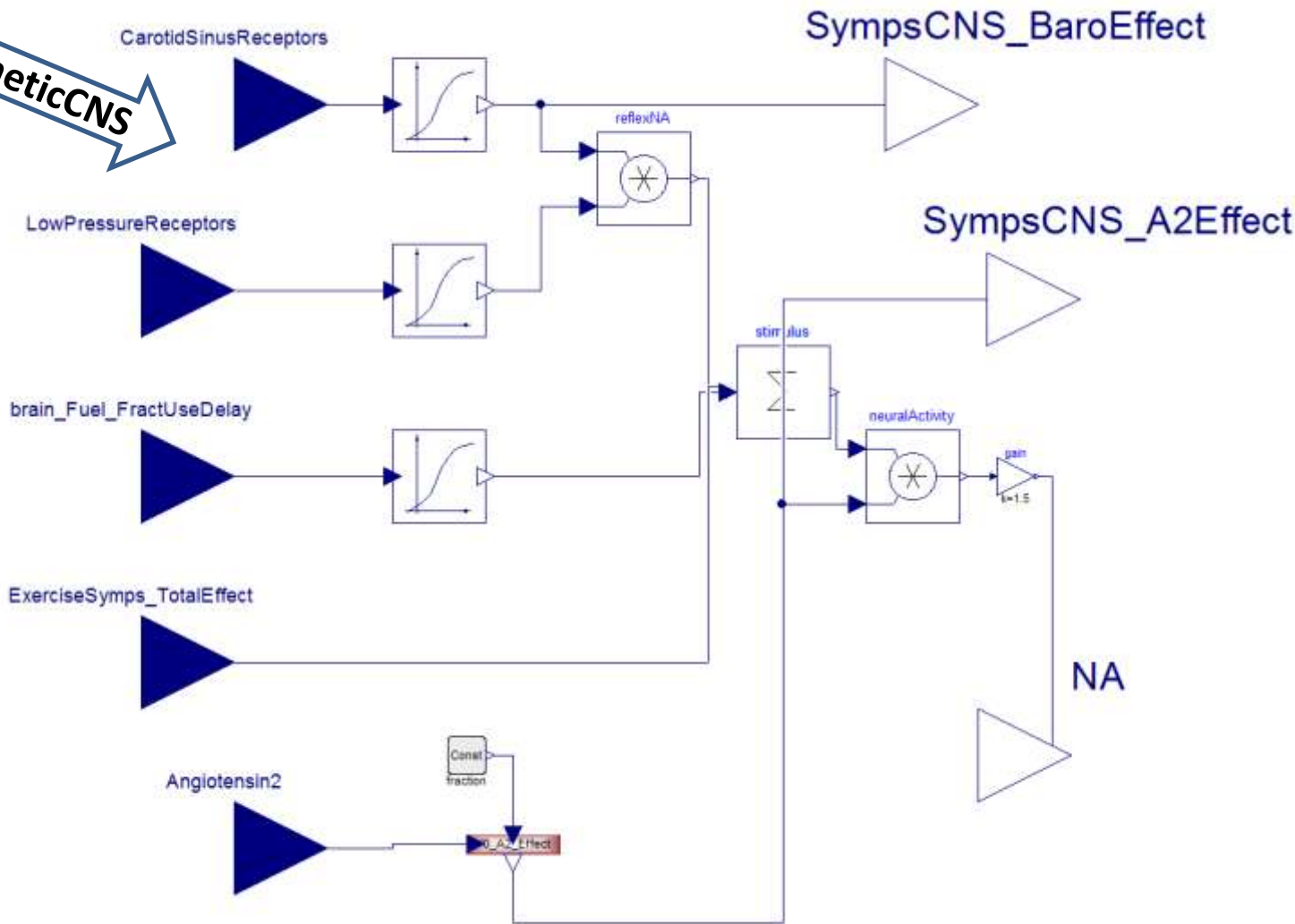

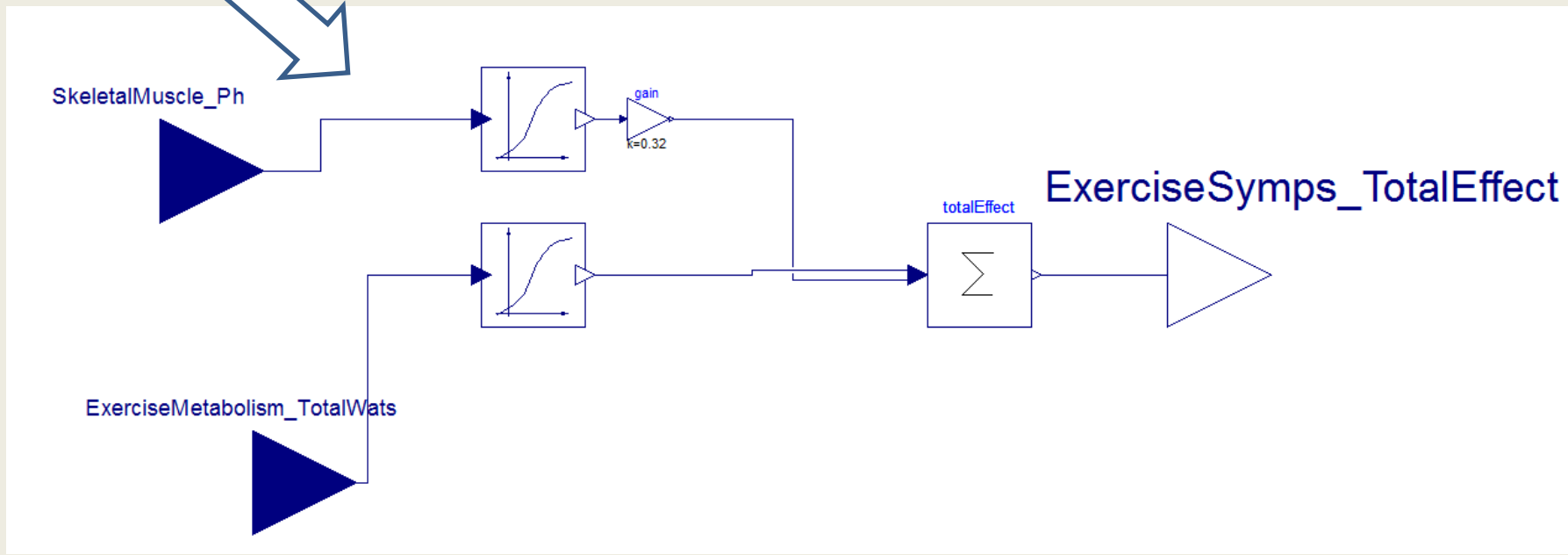
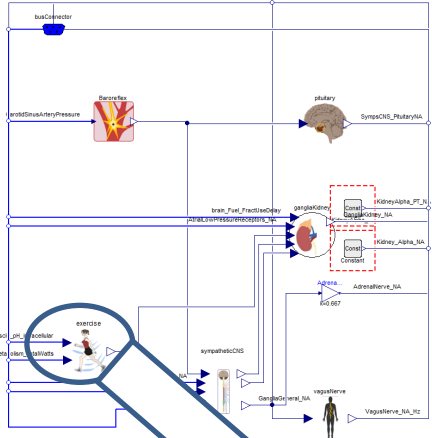

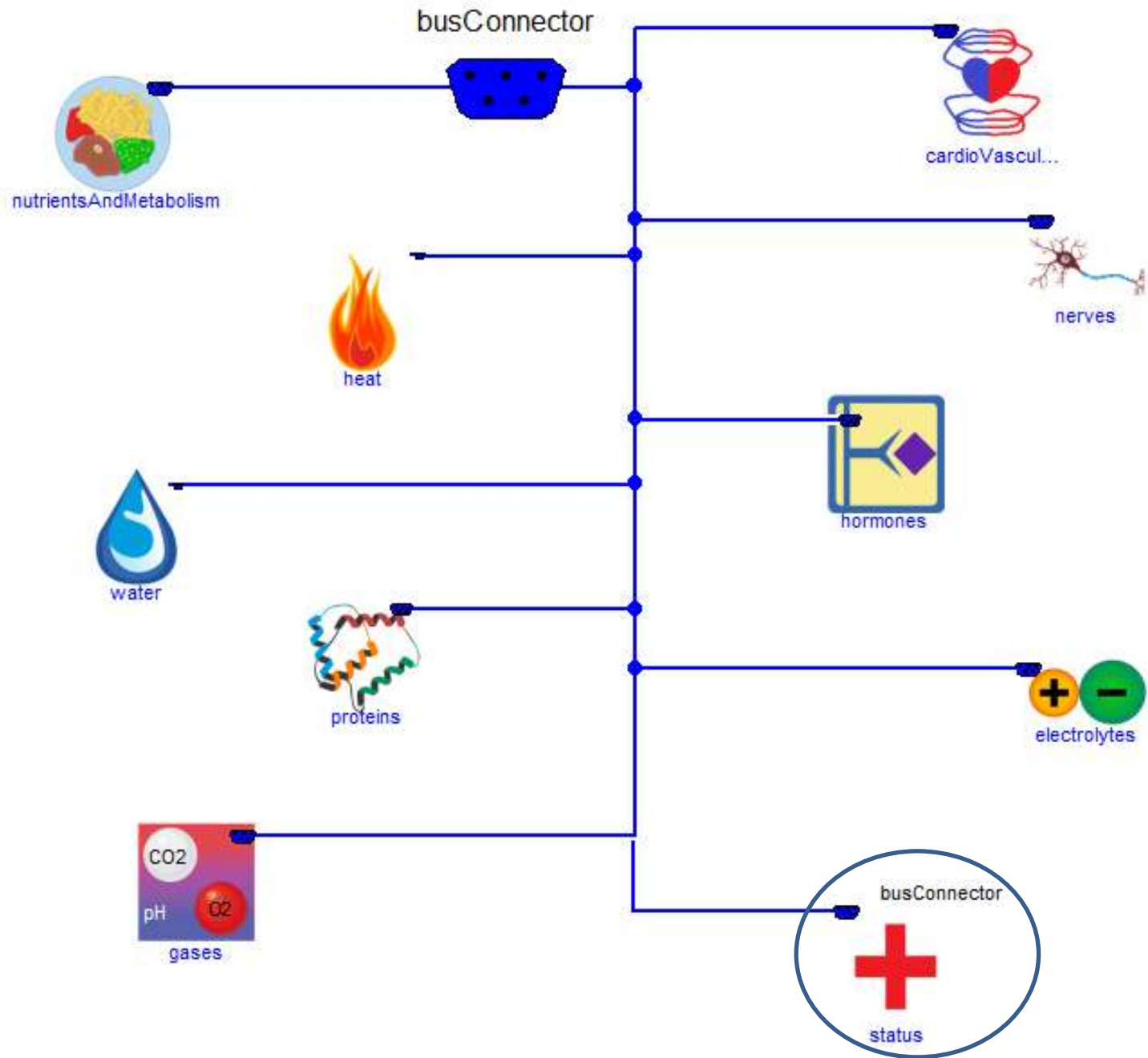

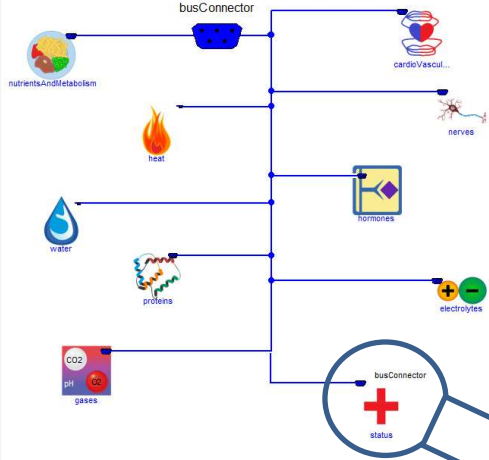

busConnector

status

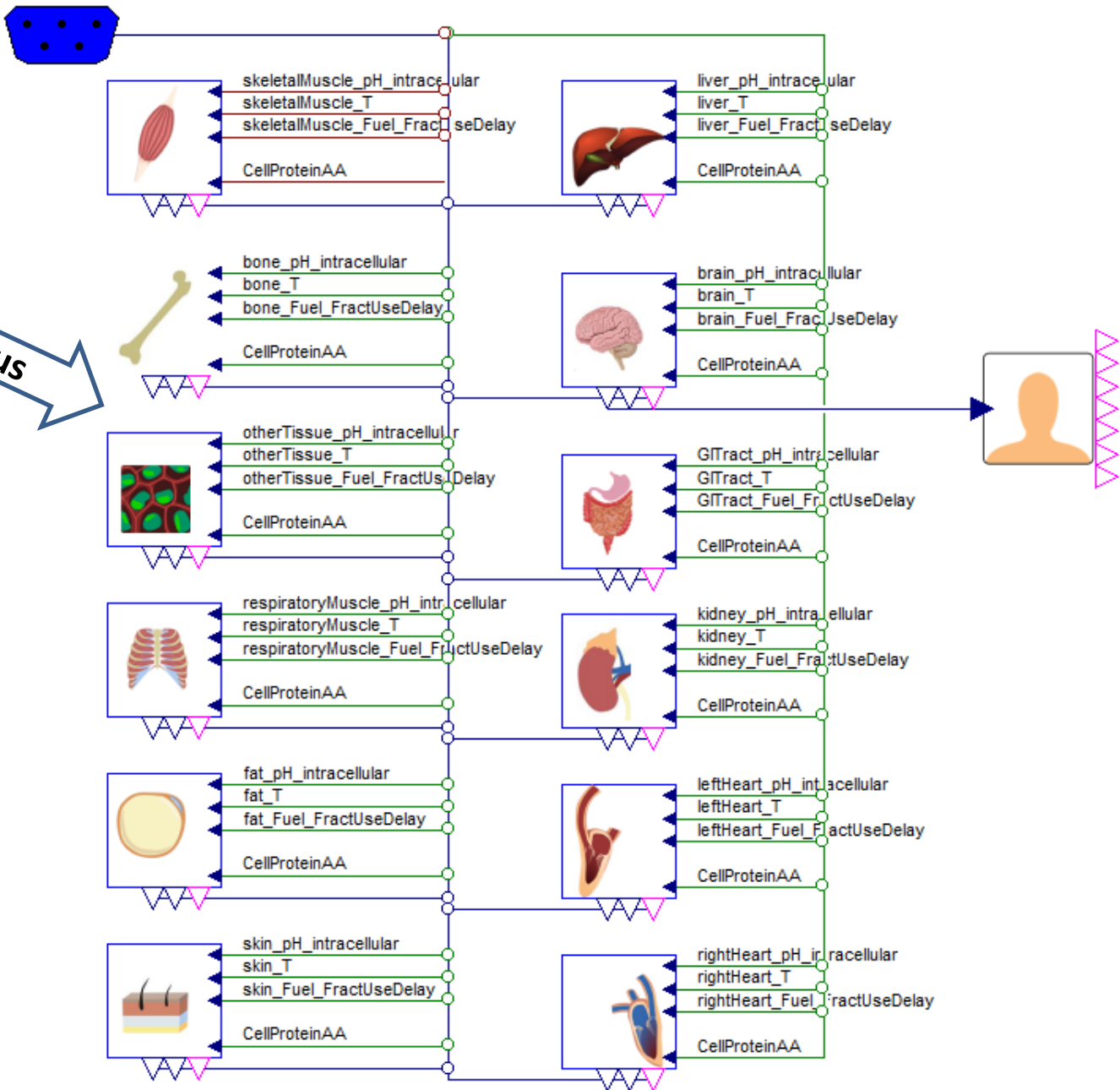

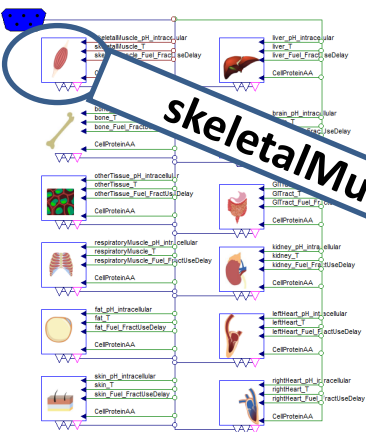

skeletalMuscle

The instances of the same class with different parameters

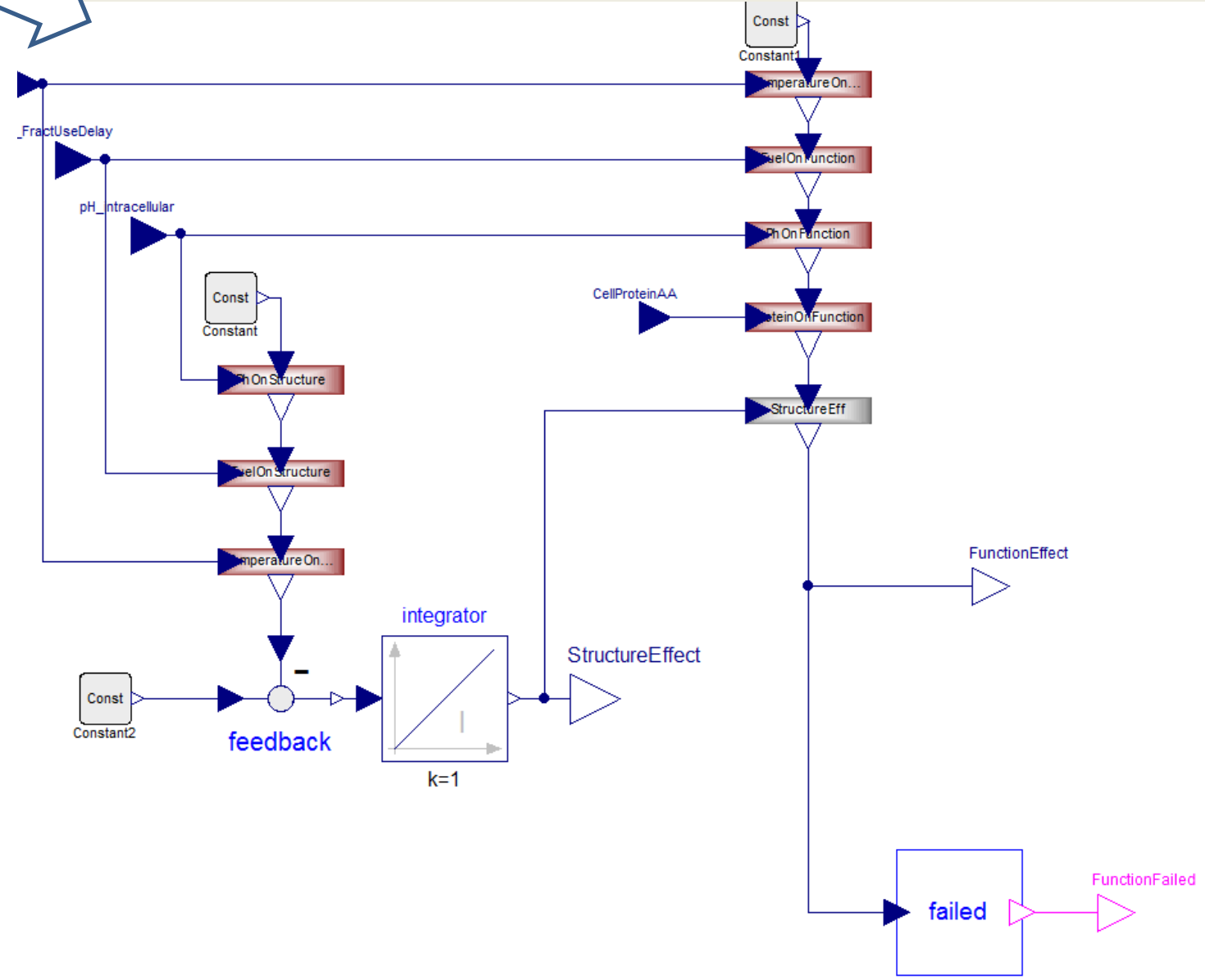

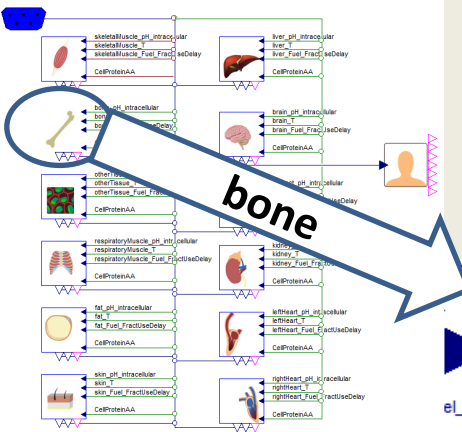

The instances of the same class with different parameters

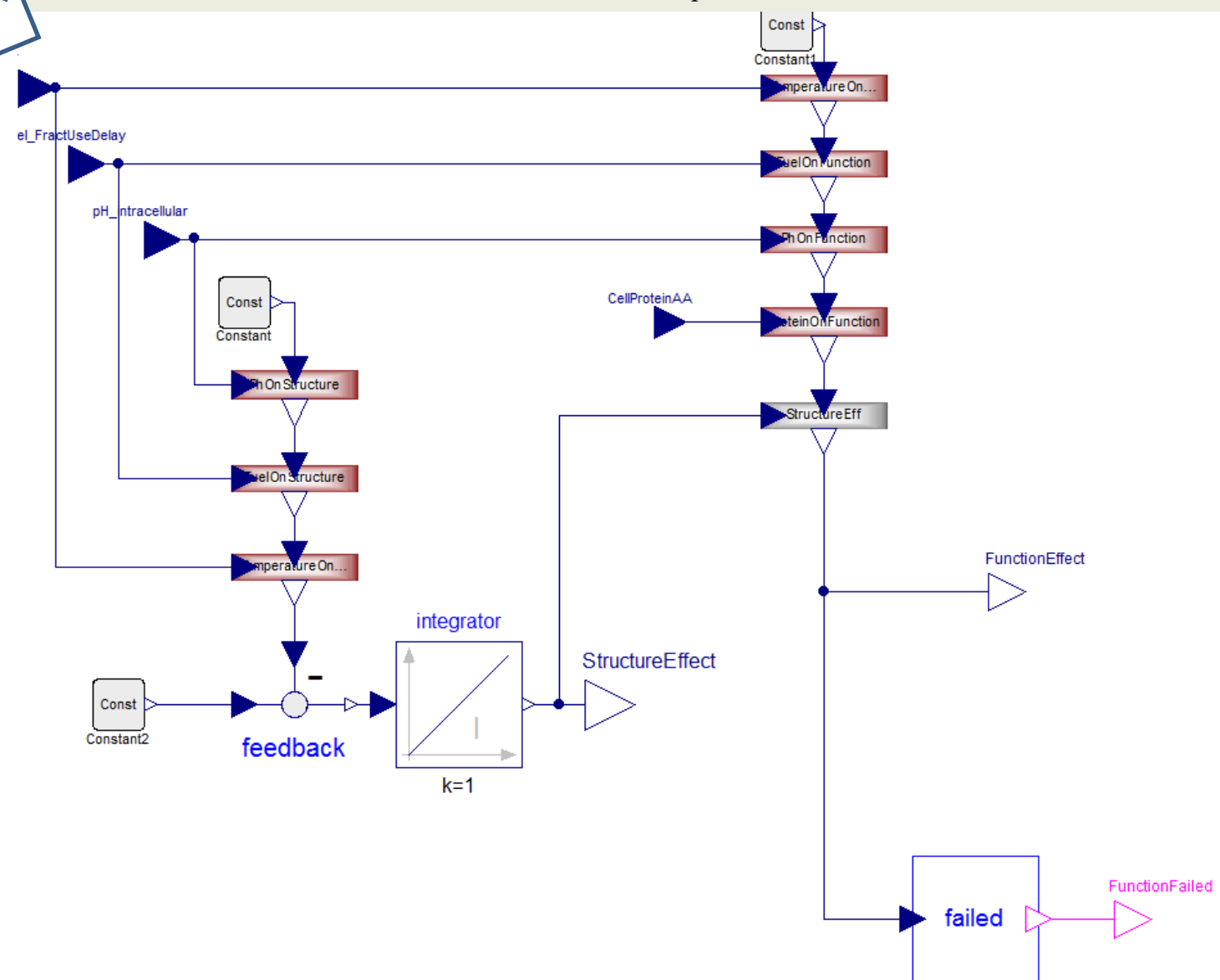

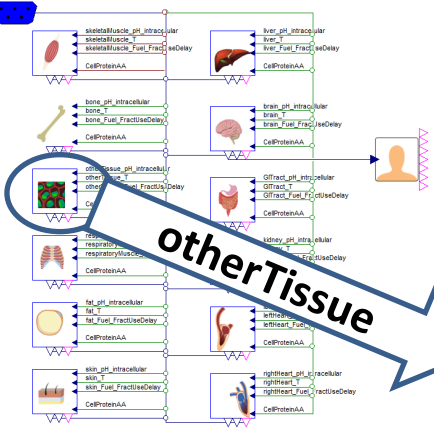

The instances of the same class with different parameters

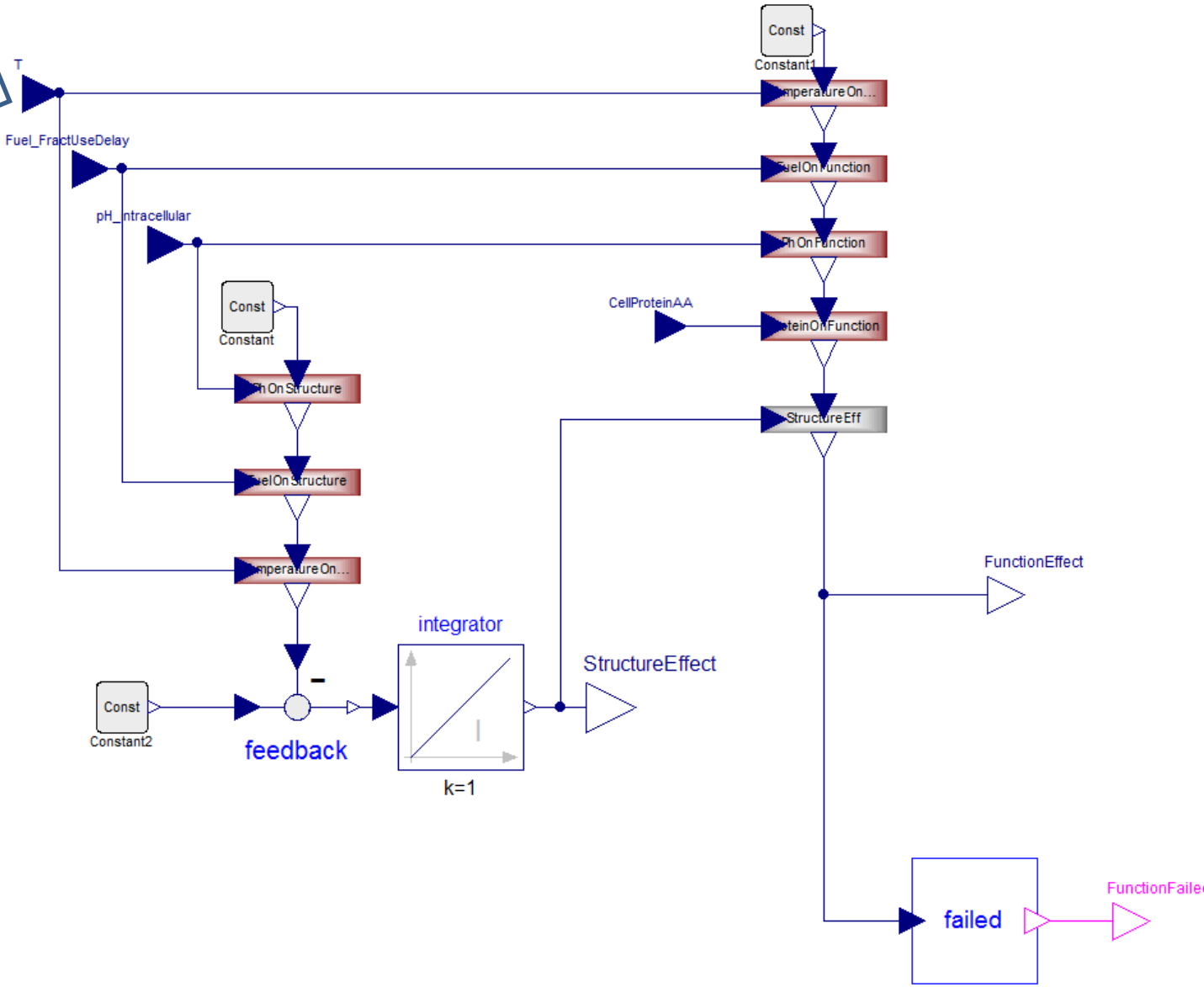

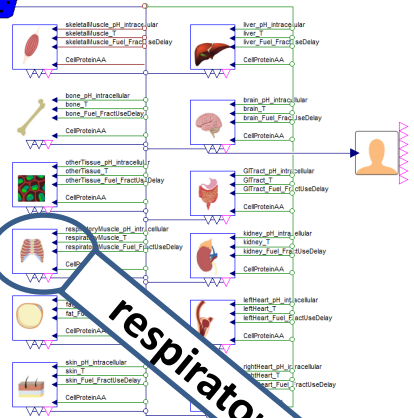

The instances of the same class with different parameters

respiratoryMuscle

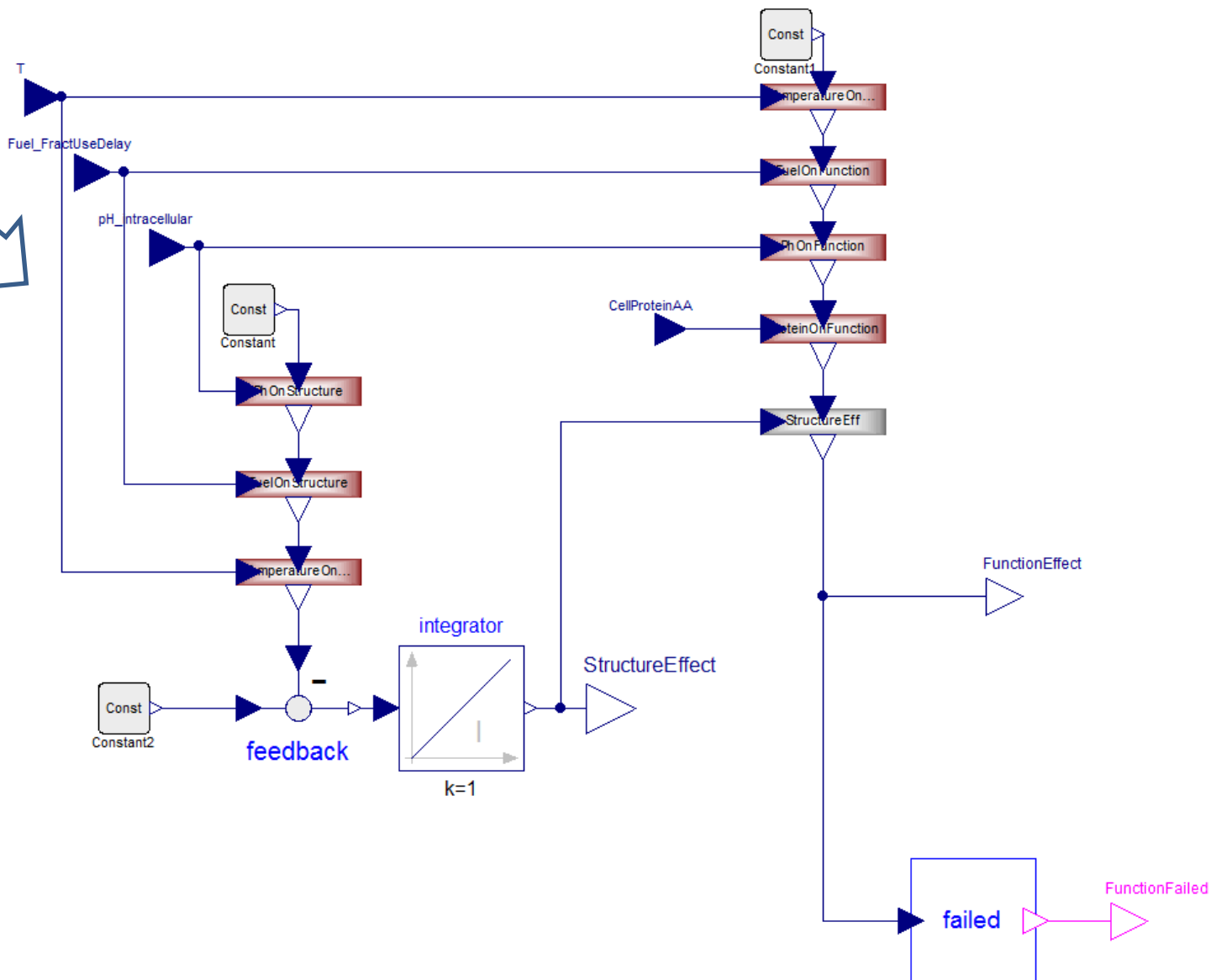

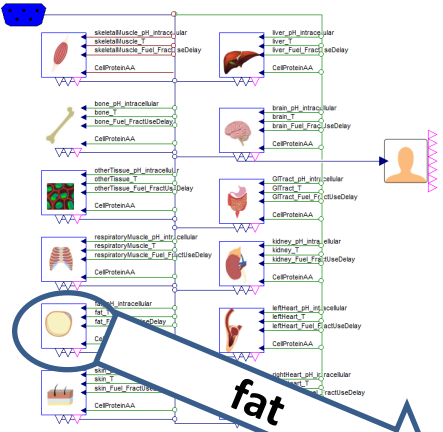

The instances of the same class with different parameters

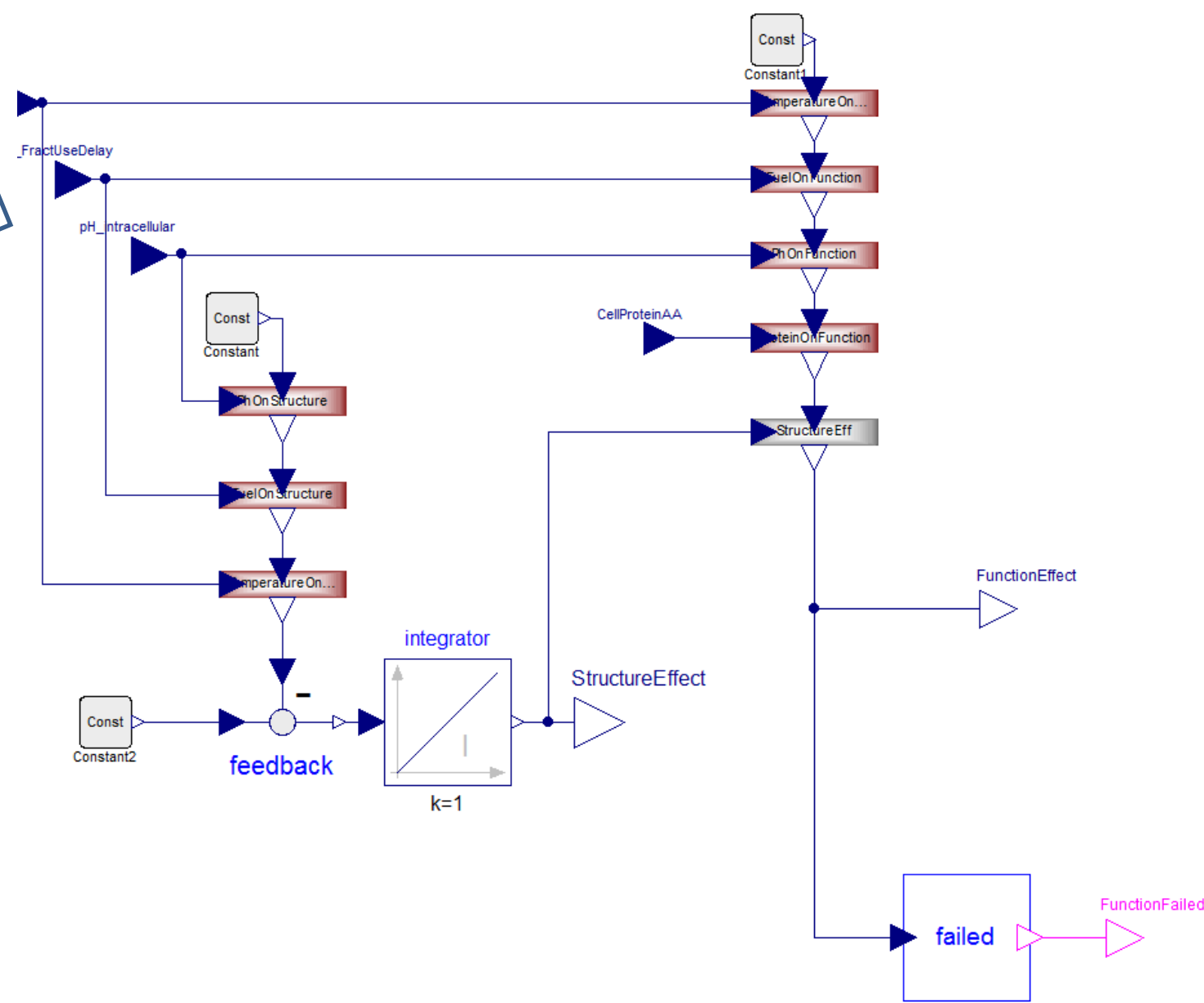

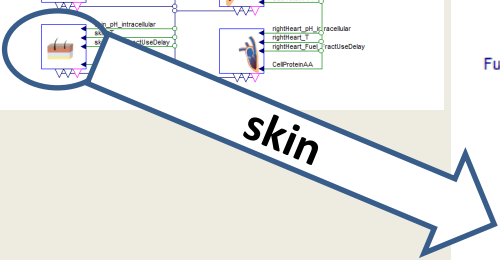
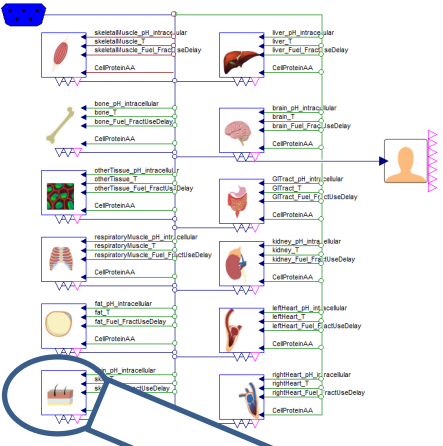

The instances of the same class with different parameters

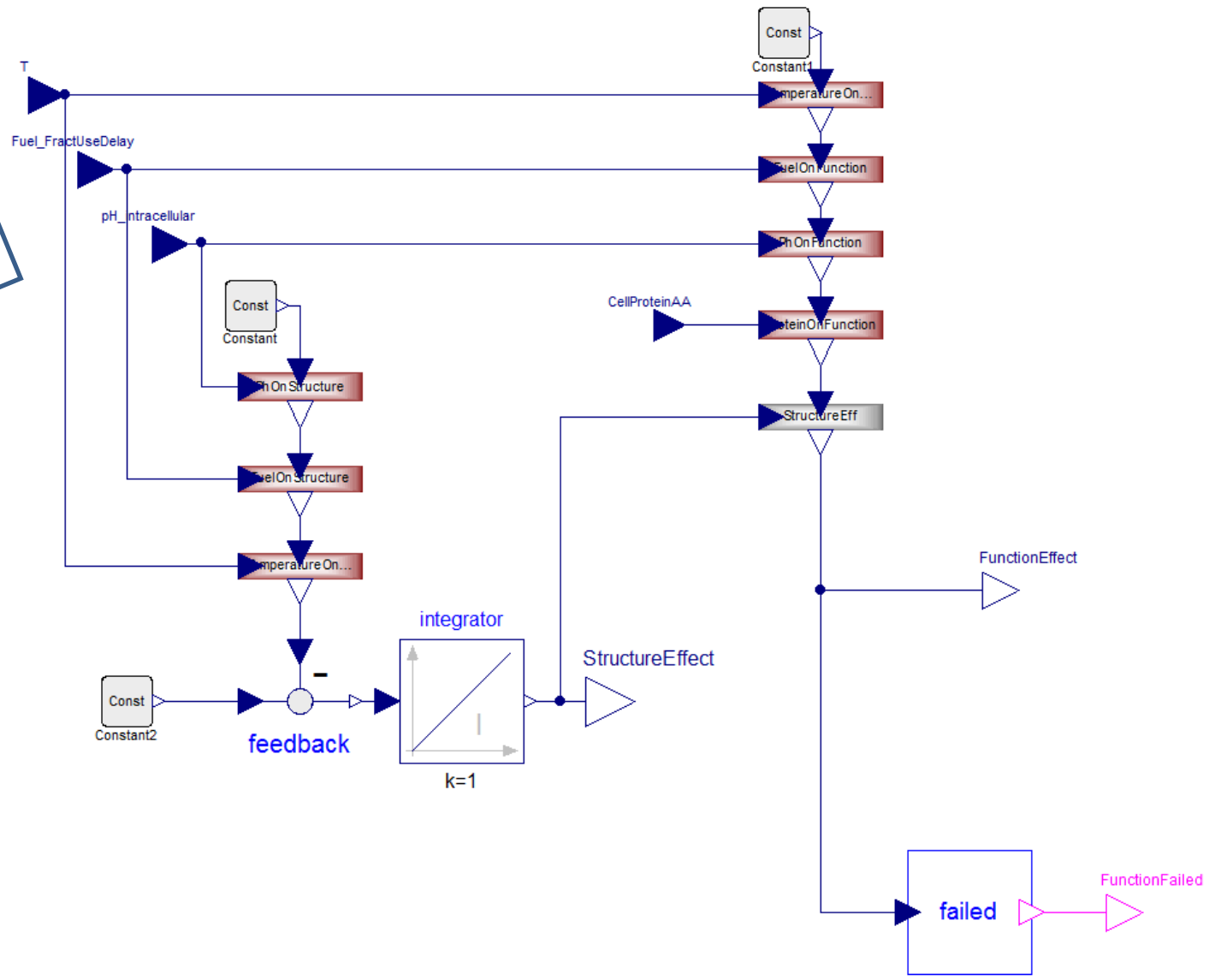

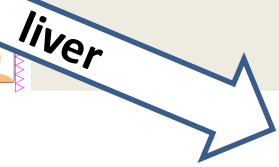
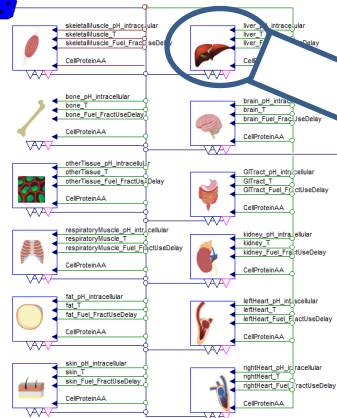

The instances of the same class with different parameters

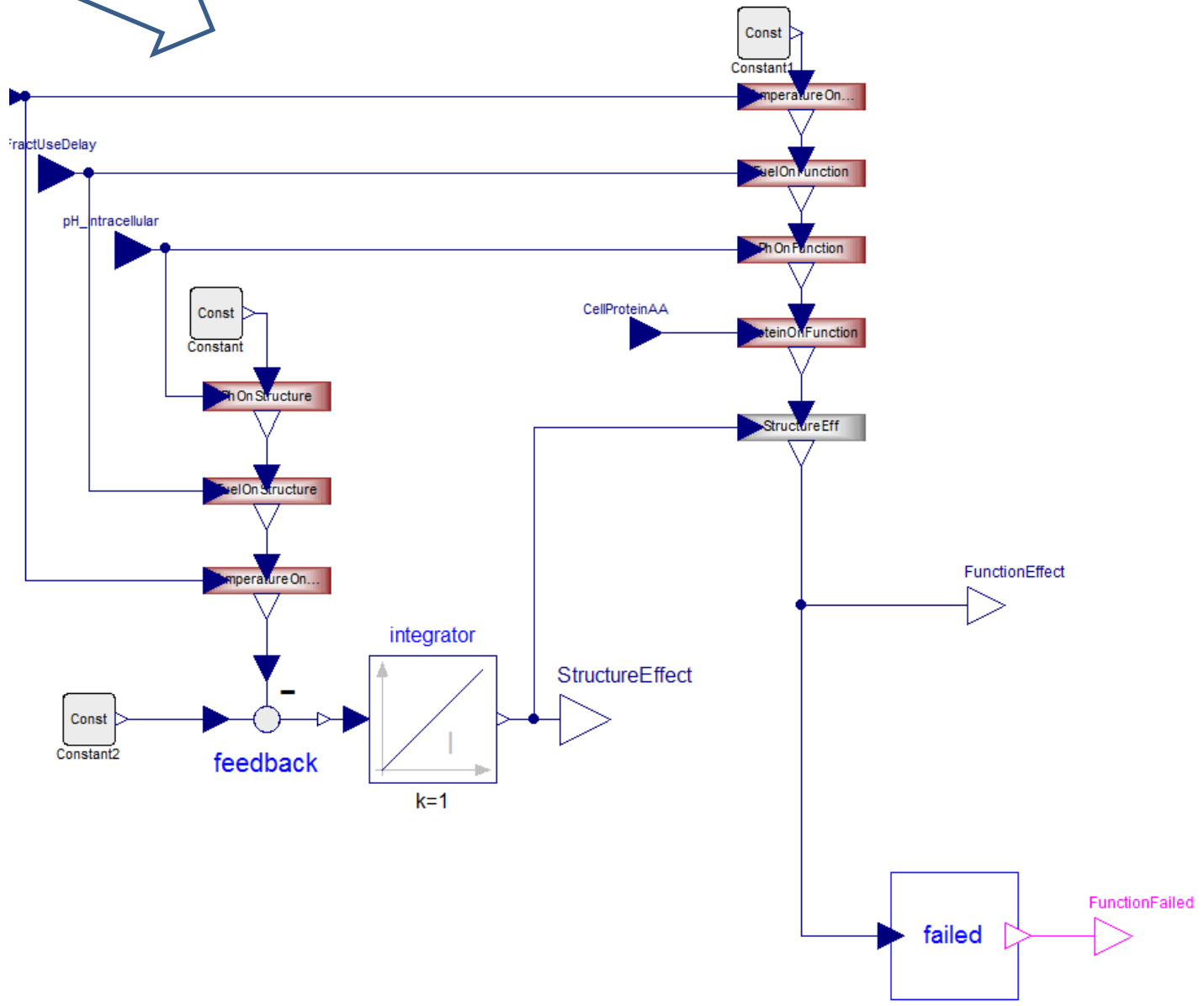

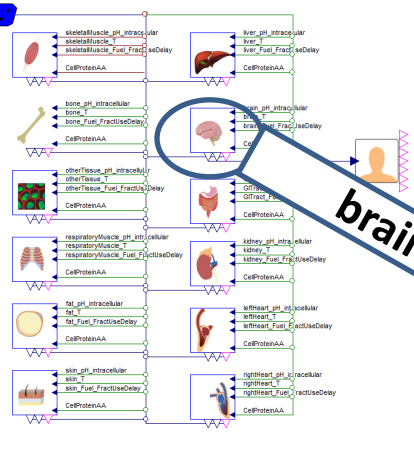

brain

The instances of the same class with different parameters

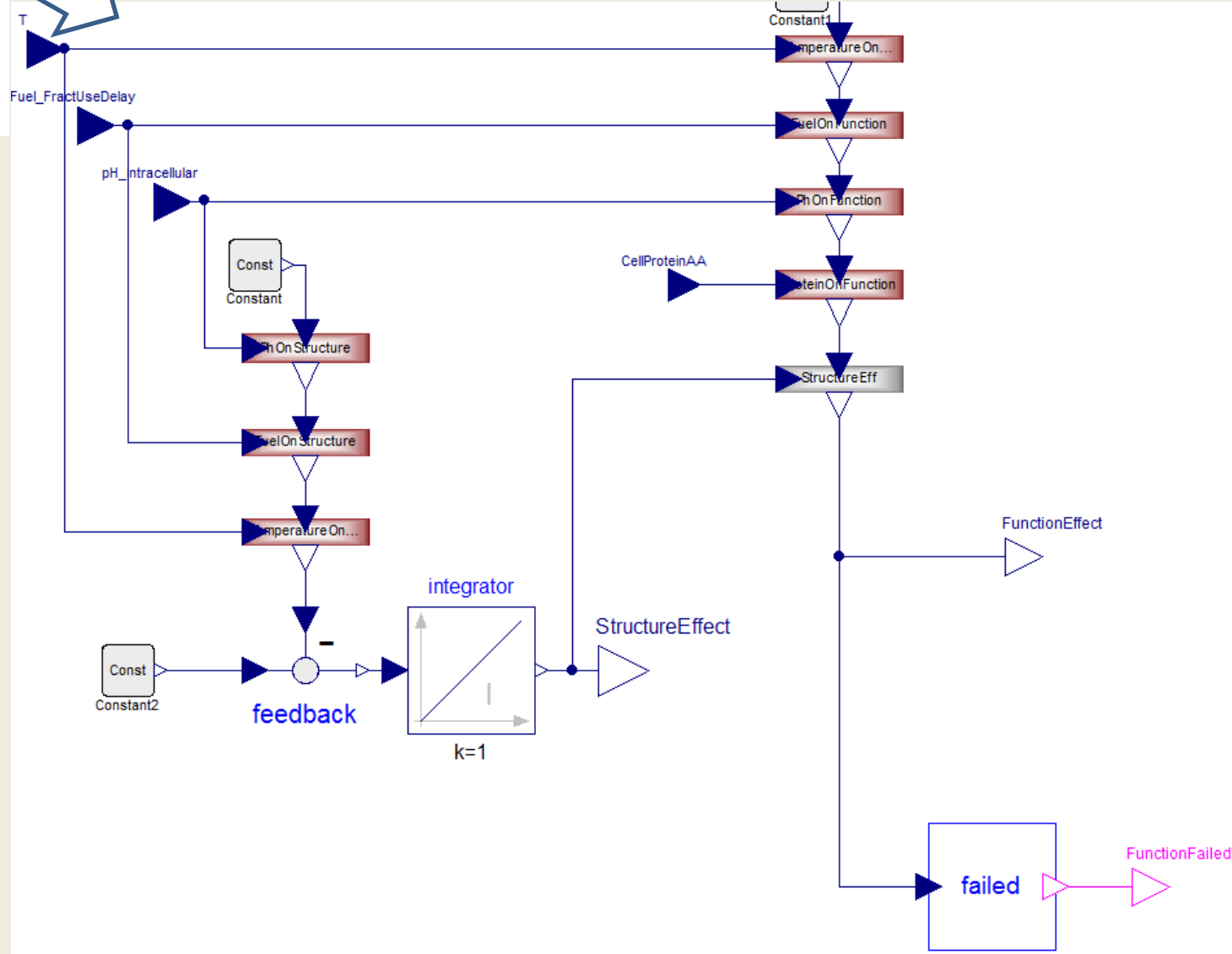

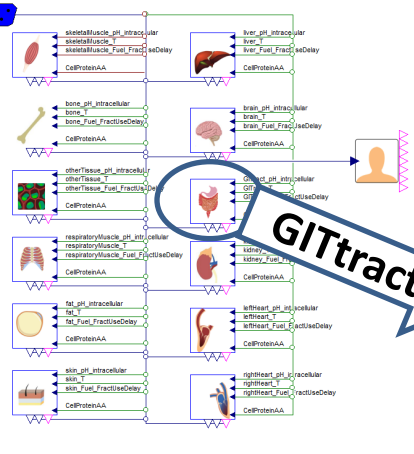

The instances of the same class with different parameters

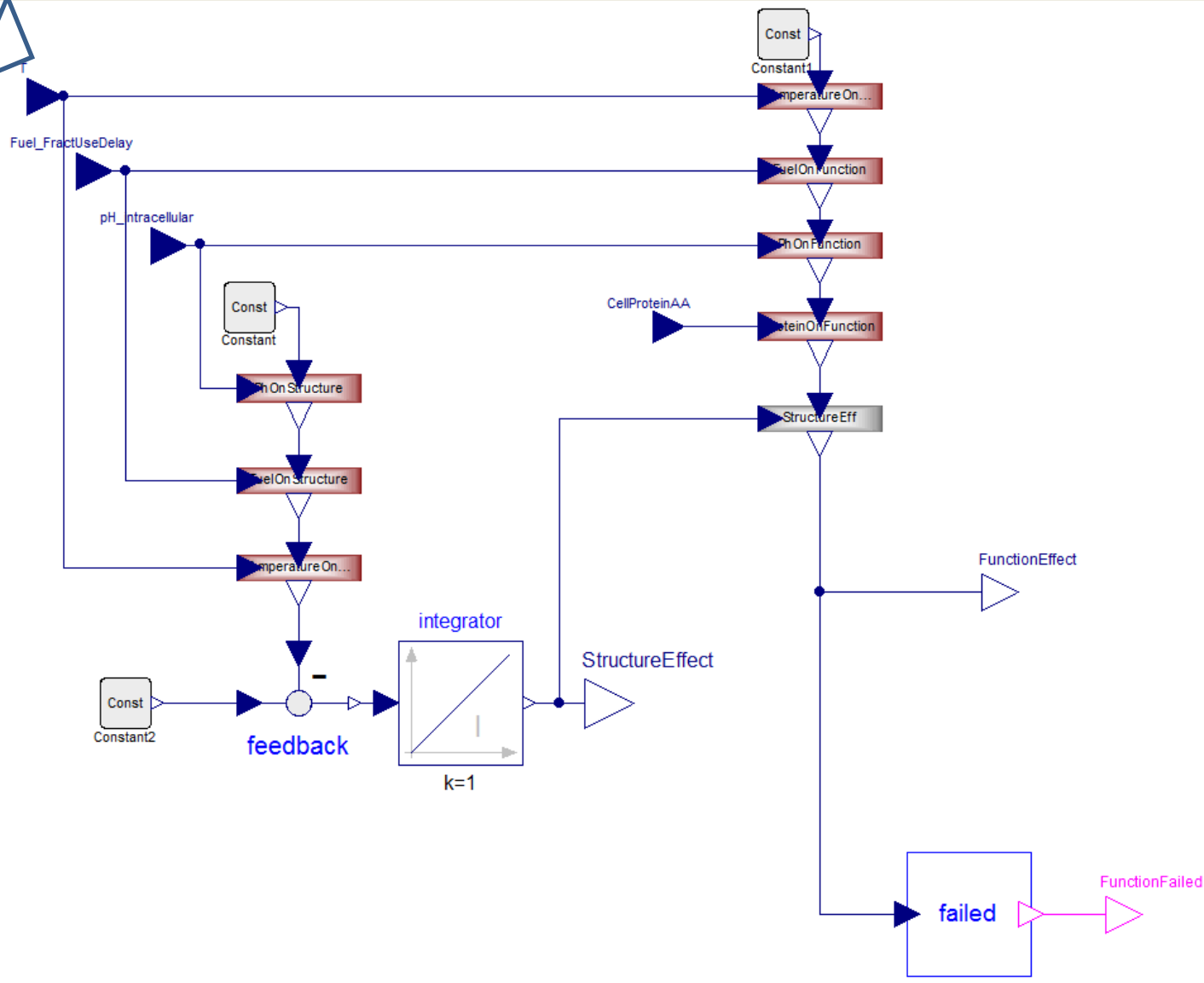

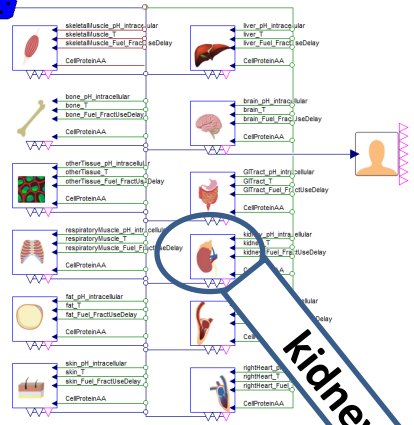

The instances of the same class with different parameters

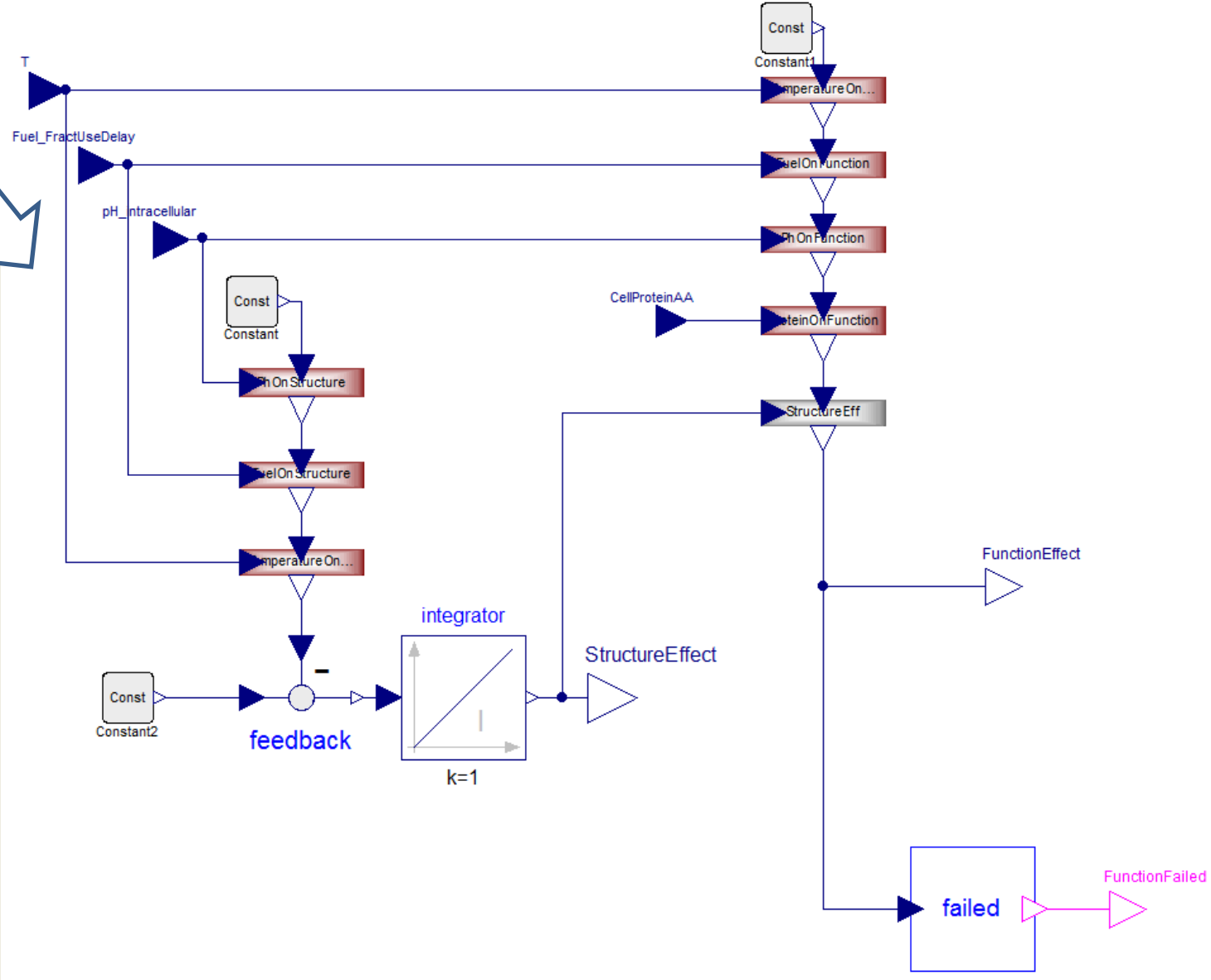

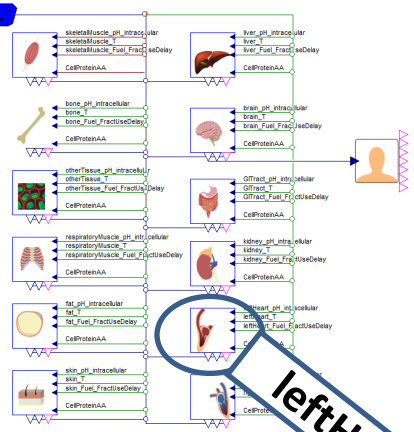

The instances of the same class with different parameters

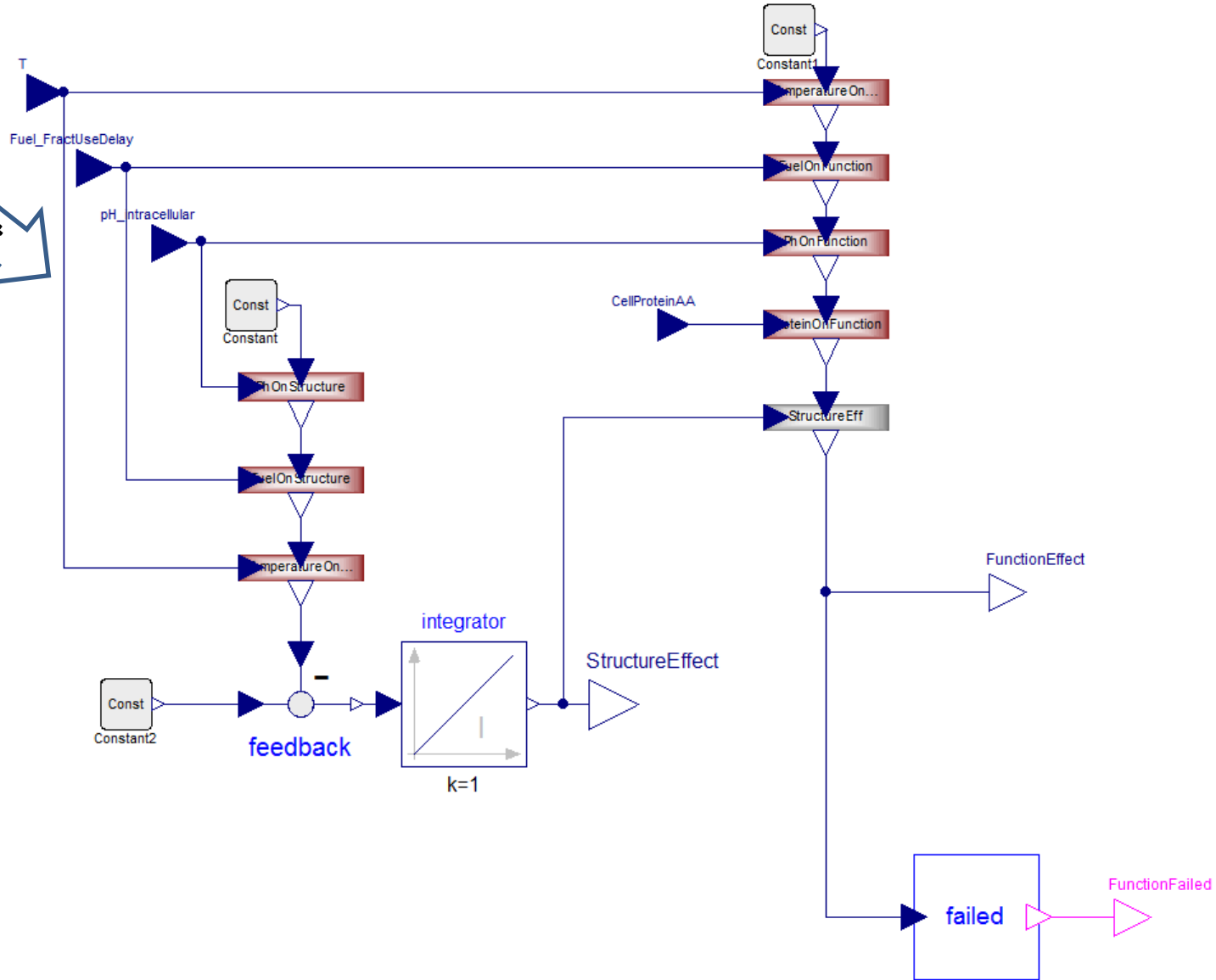

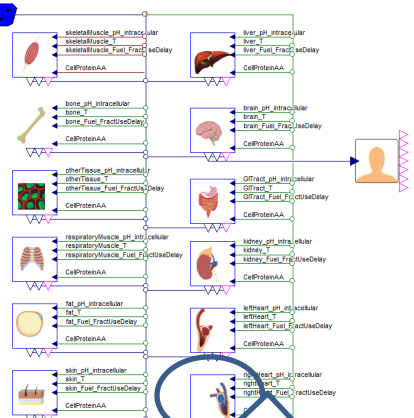

The instances of the same class with different parameters

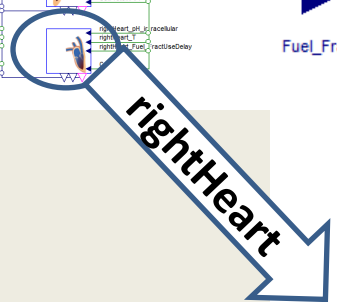

rightHeart

